

[1] POWER TRAIN

(1) Four Wheel Drive

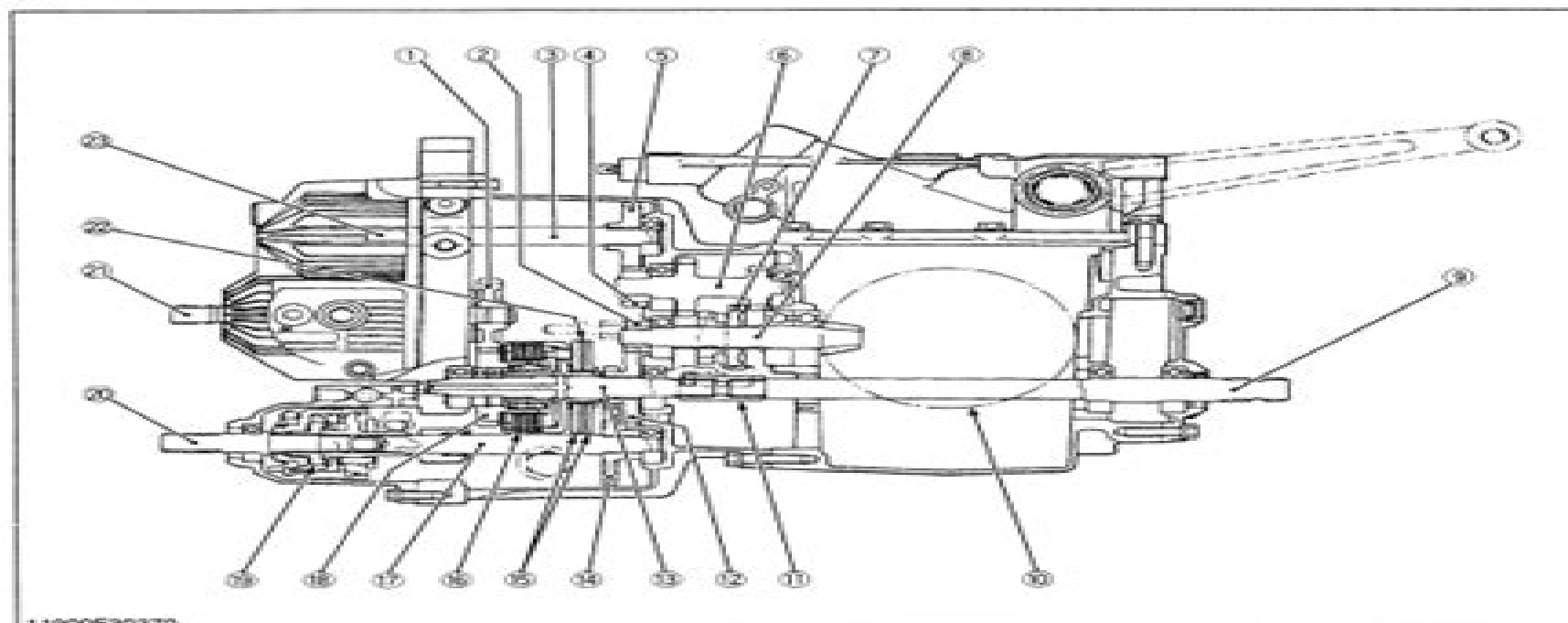

11900F30370

- | | | | |
|------------------|-------------------------------|--|-------------------------------------|
| (1) 30T Gear | (8) Spiral Bevel Pinion Shaft | (15) PTO Brake Plate | (20) RWD Shaft 2 |
| (2) 11T Gear | (9) PTO Shaft | (16) Hydraulic PTO Clutch Assembly | (21) Pump Shaft |
| (3) Motor Shaft | (10) Differential Gear | (17) RWD Shaft 1 | (22) PTO Brake Disc |
| (4) 15T Gear | (11) Coupling | (18) 32T Gear | (23) Hydrostatic Transmission (HST) |
| (5) 28T Gear | (12) 16T-33T Gear | (19) Dual-acting Overrunning Clutch (DAO Clutch) | |
| (6) 18T-17T Gear | (13) Clutch Shaft | | |
| (7) 15T-26T Gear | (14) 34T Gear | | |

The transmission consists of a series of gears shown above. It offers the most suitable speed for travelling and operation by combination of these gears.

It transmits power to the front and rear axles and PTO shaft, which are classified respectively as the travelling system and PTO system.

FORWARD AND REVERSE

■ Hi Position

Motor Shaft (3) → 28T Gear (5) → 15T Gear (4) → 18T-(17T) Gear (6) → 15T-(26T) Gear (7) → Spiral Bevel Pinion Shaft (8) → Differential Gear (10)

■ Low Position

Motor Shaft (3) → 28T Gear (5) → 15T Gear (4) → (18T)-17T Gear (6) → (15T)-26T Gear (7) → Spiral Bevel Pinion Shaft (8) → Differential Gear (10)

■ Neutral Position

Motor Shaft (3) → 28T Gear (5) → 15T Gear (4) → 18T-17T Gear (6)

■ Rear Wheel Drive

Spiral Bevel Pinion Shaft (8) → 11T Gear (2) → 16T-33T Gear (12) → RWD Shaft 1 (17) → DAO Clutch (19) → RWD Shaft 2 → Rear Differential Gear

11900M30010

Kubota F2260 F2560 F3060 Workshop Repair Service Manual

SA Adler



Kubota F2260 F2560 F3060 Workshop Repair Service Manual:

Embark on a transformative journey with Explore the World with is captivating work, Discover the Magic in **Kubota F2260 F2560 F3060 Workshop Repair Service Manual** . This enlightening ebook, available for download in a convenient PDF format , invites you to explore a world of boundless knowledge. Unleash your intellectual curiosity and discover the power of words as you dive into this riveting creation. Download now and elevate your reading experience to new heights .

https://staging.conocer.cide.edu/About/detail/Download_PDFS/massey%20ferguson%20operators%20manual%20mf%20to%2003.pdf

Table of Contents Kubota F2260 F2560 F3060 Workshop Repair Service Manual

1. Understanding the eBook Kubota F2260 F2560 F3060 Workshop Repair Service Manual
 - The Rise of Digital Reading Kubota F2260 F2560 F3060 Workshop Repair Service Manual
 - Advantages of eBooks Over Traditional Books
2. Identifying Kubota F2260 F2560 F3060 Workshop Repair Service Manual
 - Exploring Different Genres
 - Considering Fiction vs. Non-Fiction
 - Determining Your Reading Goals
3. Choosing the Right eBook Platform
 - Popular eBook Platforms
 - Features to Look for in an Kubota F2260 F2560 F3060 Workshop Repair Service Manual
 - User-Friendly Interface
4. Exploring eBook Recommendations from Kubota F2260 F2560 F3060 Workshop Repair Service Manual
 - Personalized Recommendations
 - Kubota F2260 F2560 F3060 Workshop Repair Service Manual User Reviews and Ratings
 - Kubota F2260 F2560 F3060 Workshop Repair Service Manual and Bestseller Lists
5. Accessing Kubota F2260 F2560 F3060 Workshop Repair Service Manual Free and Paid eBooks
 - Kubota F2260 F2560 F3060 Workshop Repair Service Manual Public Domain eBooks
 - Kubota F2260 F2560 F3060 Workshop Repair Service Manual eBook Subscription Services

- Kubota F2260 F2560 F3060 Workshop Repair Service Manual Budget-Friendly Options
- 6. Navigating Kubota F2260 F2560 F3060 Workshop Repair Service Manual eBook Formats
 - ePub, PDF, MOBI, and More
 - Kubota F2260 F2560 F3060 Workshop Repair Service Manual Compatibility with Devices
 - Kubota F2260 F2560 F3060 Workshop Repair Service Manual Enhanced eBook Features
- 7. Enhancing Your Reading Experience
 - Adjustable Fonts and Text Sizes of Kubota F2260 F2560 F3060 Workshop Repair Service Manual
 - Highlighting and Note-Taking Kubota F2260 F2560 F3060 Workshop Repair Service Manual
 - Interactive Elements Kubota F2260 F2560 F3060 Workshop Repair Service Manual
- 8. Staying Engaged with Kubota F2260 F2560 F3060 Workshop Repair Service Manual
 - Joining Online Reading Communities
 - Participating in Virtual Book Clubs
 - Following Authors and Publishers Kubota F2260 F2560 F3060 Workshop Repair Service Manual
- 9. Balancing eBooks and Physical Books Kubota F2260 F2560 F3060 Workshop Repair Service Manual
 - Benefits of a Digital Library
 - Creating a Diverse Reading Collection Kubota F2260 F2560 F3060 Workshop Repair Service Manual
- 10. Overcoming Reading Challenges
 - Dealing with Digital Eye Strain
 - Minimizing Distractions
 - Managing Screen Time
- 11. Cultivating a Reading Routine Kubota F2260 F2560 F3060 Workshop Repair Service Manual
 - Setting Reading Goals Kubota F2260 F2560 F3060 Workshop Repair Service Manual
 - Carving Out Dedicated Reading Time
- 12. Sourcing Reliable Information of Kubota F2260 F2560 F3060 Workshop Repair Service Manual
 - Fact-Checking eBook Content of Kubota F2260 F2560 F3060 Workshop Repair Service Manual
 - Distinguishing Credible Sources
- 13. Promoting Lifelong Learning
 - Utilizing eBooks for Skill Development
 - Exploring Educational eBooks
- 14. Embracing eBook Trends

- Integration of Multimedia Elements
- Interactive and Gamified eBooks

Kubota F2260 F2560 F3060 Workshop Repair Service Manual Introduction

In the digital age, access to information has become easier than ever before. The ability to download Kubota F2260 F2560 F3060 Workshop Repair Service Manual has revolutionized the way we consume written content. Whether you are a student looking for course material, an avid reader searching for your next favorite book, or a professional seeking research papers, the option to download Kubota F2260 F2560 F3060 Workshop Repair Service Manual has opened up a world of possibilities. Downloading Kubota F2260 F2560 F3060 Workshop Repair Service Manual provides numerous advantages over physical copies of books and documents. Firstly, it is incredibly convenient. Gone are the days of carrying around heavy textbooks or bulky folders filled with papers. With the click of a button, you can gain immediate access to valuable resources on any device. This convenience allows for efficient studying, researching, and reading on the go. Moreover, the cost-effective nature of downloading Kubota F2260 F2560 F3060 Workshop Repair Service Manual has democratized knowledge. Traditional books and academic journals can be expensive, making it difficult for individuals with limited financial resources to access information. By offering free PDF downloads, publishers and authors are enabling a wider audience to benefit from their work. This inclusivity promotes equal opportunities for learning and personal growth. There are numerous websites and platforms where individuals can download Kubota F2260 F2560 F3060 Workshop Repair Service Manual. These websites range from academic databases offering research papers and journals to online libraries with an expansive collection of books from various genres. Many authors and publishers also upload their work to specific websites, granting readers access to their content without any charge. These platforms not only provide access to existing literature but also serve as an excellent platform for undiscovered authors to share their work with the world. However, it is essential to be cautious while downloading Kubota F2260 F2560 F3060 Workshop Repair Service Manual. Some websites may offer pirated or illegally obtained copies of copyrighted material. Engaging in such activities not only violates copyright laws but also undermines the efforts of authors, publishers, and researchers. To ensure ethical downloading, it is advisable to utilize reputable websites that prioritize the legal distribution of content. When downloading Kubota F2260 F2560 F3060 Workshop Repair Service Manual, users should also consider the potential security risks associated with online platforms. Malicious actors may exploit vulnerabilities in unprotected websites to distribute malware or steal personal information. To protect themselves, individuals should ensure their devices have reliable antivirus software installed and validate the legitimacy of the websites they are downloading from. In conclusion, the ability to download Kubota F2260 F2560 F3060 Workshop Repair Service Manual has transformed the way we access information. With the convenience, cost-effectiveness, and accessibility it offers,

free PDF downloads have become a popular choice for students, researchers, and book lovers worldwide. However, it is crucial to engage in ethical downloading practices and prioritize personal security when utilizing online platforms. By doing so, individuals can make the most of the vast array of free PDF resources available and embark on a journey of continuous learning and intellectual growth.

FAQs About Kubota F2260 F2560 F3060 Workshop Repair Service Manual Books

How do I know which eBook platform is the best for me? Finding the best eBook platform depends on your reading preferences and device compatibility. Research different platforms, read user reviews, and explore their features before making a choice. Are free eBooks of good quality? Yes, many reputable platforms offer high-quality free eBooks, including classics and public domain works. However, make sure to verify the source to ensure the eBook credibility. Can I read eBooks without an eReader? Absolutely! Most eBook platforms offer web-based readers or mobile apps that allow you to read eBooks on your computer, tablet, or smartphone. How do I avoid digital eye strain while reading eBooks? To prevent digital eye strain, take regular breaks, adjust the font size and background color, and ensure proper lighting while reading eBooks. What the advantage of interactive eBooks? Interactive eBooks incorporate multimedia elements, quizzes, and activities, enhancing the reader engagement and providing a more immersive learning experience. Kubota F2260 F2560 F3060 Workshop Repair Service Manual is one of the best book in our library for free trial. We provide copy of Kubota F2260 F2560 F3060 Workshop Repair Service Manual in digital format, so the resources that you find are reliable. There are also many Ebooks of related with Kubota F2260 F2560 F3060 Workshop Repair Service Manual. Where to download Kubota F2260 F2560 F3060 Workshop Repair Service Manual online for free? Are you looking for Kubota F2260 F2560 F3060 Workshop Repair Service Manual PDF? This is definitely going to save you time and cash in something you should think about.

Find Kubota F2260 F2560 F3060 Workshop Repair Service Manual :

massey ferguson operators manual mf to 30

massey ferguson 231s maintenance manual

mastercam training guide taringa

mastering physics chapter answers

massey ferguson 228 round baler manual

mastercam x7 manual

[massey ferguson 50 owners manual](#)

[massey ferguson combine 52 owners manual](#)

[master 20 inheritance of human traits answer key](#)

massey ferguson 65 operator manual

matching rock layers lab answer key

[massey ferguson mf 5300 series tractors service manual](#)

massey ferguson 37 hay rake manual

[mastering physics solutions manual giancoli](#)

[massey ferguson 3505 parts manual](#)

Kubota F2260 F2560 F3060 Workshop Repair Service Manual :

das geheimnis glücklicher kinder orell füssli - Nov 18 2021

web hier erfahren eltern was in ihren kindern wirklich vor sich geht und wie man am besten darauf reagiert ein tatsächlich einzigartiges buch das die üblichen ratgeber weit

das geheimnis glücklicher kinder amazon de - Oct 10 2023

web eigentlich ist steve biddulph 1953 in england geboren ein zurückhaltender mensch doch wenn er für einen seiner vorträge die bühne betritt fällt alle schüchternheit von ihm ab

das geheimnis glücklicher kinder hörbuch download mp3 - Jul 27 2022

web additional physical form entry erscheint auch als notes

[das geheimnis glücklicher kinder 6 tipps 8 methoden](#) - Sep 09 2023

web das geheimnis glücklicher kinder hörbuch download steve biddulph oliver wronka lagato verlag amazon de bücher

das geheimnis glücklicher kinder bücher de - Oct 30 2022

web jan 29 2014 b der weltbestseller von steve biddulph mit über 500 000 verkauften exemplaren allein in deutschland b br br der psychologe und familientherapeut

das geheimnis glücklicher kinder thalia at - Feb 02 2023

web das geheimnis glücklicher kinder autor steve biddulph 4sterne 6 hineinblättern merken der etwas andere ratgeber der neue antworten auf die ewigen fragen der erziehung

das geheimnis glücklicher kinder amazon de - Aug 08 2023

web der weltbestseller von steve biddulph mit über 500 000 verkauften exemplaren allein in deutschland der psychologe und familientherapeut steve biddulph gibt eltern

das geheimnis glücklicher kinder - Feb 19 2022

web 15 hours ago zum audio das geheimnis 04 11 23 la banda capelli zur Übersicht klassik für kinder do re mikro zum nachhören zur Übersicht hörspiele zum

das geheimnis glücklicher kinder weltbild - Jan 01 2023

web jan 29 2014 der weltbestseller von steve biddulph allein in deutschland über 500 000 verkaufte exemplare der psychologe und familientherapeut steve biddulph gibt eltern

das geheimnis glücklicher kinder von steve biddulph - Jul 07 2023

web das geheimnis glücklicher kinder und weitere geheimnisse glücklicher kinder die beiden weltbestseller in einem band biddulph steve isbn 9783453600799

das geheimnis glücklicher kinder worldcat org - Jun 25 2022

web der weltbestseller von steve biddulph mit über 500 000 verkauften exemplaren allein in deutschland der psychologe und familientherapeut steve biddulph gibt eltern

das geheimnis glücklicher kinder e book epub k - Sep 28 2022

web jan 29 2014 hier erfahren eltern was in ihren kindern wirklich vor sich geht und wie man am besten darauf reagiert ein tatsächlich einzigartiges buch das die üblichen

das geheimnis 11 11 23 la banda capelli gefährliche Überfahrt - Jan 21 2022

web glückskinder ist eine 1936 im stil amerikanischer screwball comedies gedrehte deutsche filmkomödie mit dem traumpaar des deutschen films der 1930er jahre lilian harvey

das geheimnis glücklicher kinder overdrive - Aug 28 2022

web mar 8 2017 für einen entspannteren umgang mit dem nachwuchs ob kinder glücklich sind und sich zu selbstbewussten fröhlichen menschen entwickeln hängt im

das geheimnis glücklicher kinder ebook steve biddulph - May 05 2023

web das geheimnis glücklicher kinder des weltbekannten familientherapeuten und psychologen steve biddulph revolutioniert mit seinem von humor und

das geheimnis glücklicher kinder und weitere geheimnisse - Jun 06 2023

web das geheimnis glücklicher kinder der weltbestseller von steve biddulph mit über 500 000 verkauften exemplaren allein in deutschland der psychologe und das

das geheimnis glücklicher kinder steve biddulph e book - May 25 2022

web jun 6 2023 das geheimnis glücklicher kinder ist ein ratgeber für eltern der sich mit der frage auseinandersetzt wie man kinder in einer zunehmend komplexen welt

das geheimnis glücklicher kinder audible com - Mar 23 2022

web sep 27 2023 das geheimnis glücklicher kinder heyne 9783453197428 09909771 anzahl seiten 224 auflage 21 a steve biddulph taschenbuch kartoniert

das geheimnis glücklicher kinder von steve biddulph ebook - Oct 18 2021

das geheimnis glücklicher kinder taschenbuchausg - Apr 04 2023

web mar 8 2017 für einen entspannteren umgang mit dem nachwuchs ob kinder glücklich sind und sich zu selbstbewussten fröhlichen menschen entwickeln hängt im

das geheimnis glücklicher kinder overdrive - Mar 03 2023

web der weltbestseller von steve biddulph mit über 500 000 verkauften exemplaren allein in deutschland der psychologe und familientherapeut steve biddulph gibt eltern

das geheimnis glücklicher kinder on apple books - Nov 30 2022

web dabei funktioniert die erziehung wie der anerkannte australische psychologe steve biddulph in seinem weltbestseller das geheimnis glücklicher kinder zeigt auf der

glückskinder wikipedia - Dec 20 2021

web der weltbestseller von steve biddulph mit über 500 000 verkauften exemplaren allein in deutschland der psychologe und familientherapeut steve biddulph gibt eltern

das geheimnis glücklicher kinder 2023 heyava - Apr 23 2022

web the 13 chapters of the art of war each devoted to one aspect of warfare were compiled by the high ranking chinese military general strategist and philosopher sun tzu in spite of

experience psychology king laura a laura ann free download - Aug 15 2023

web experience psychology king laura a laura ann free download borrow and streaming internet archive experience psychology by king laura a laura ann publication date 2013 topics psychology psychologie psychology publisher new york ny mcgraw hill collection inlibrary printdisabled internetarchivebooks contributor

experience psychology 4th edition laura king pdf - Nov 06 2022

web sep 19 2021 experience psychology 4th edition laura king pdf i m trying to get this textbook as a pdf so i can read it offline anyone know where i can find it 3 4

experience psychology 4th edition by laura king textook - Sep 04 2022

web experience psychology 4th edition by laura king 18 00 format pdf etextbooks isbn 13 978 1260397109 isbn 10 1260397106 delivery instant download authors laura a king publisher mcgraw hill education availability in stock

[looking for a pdf of experience psychology 5th edition laura king](#) - Jul 14 2023

web jan 12 2023 i am looking for a pdf version of experience psychology 5th edition isbn 9781260714593 publication date 2021 09 08 author laura king publisher mcgraw hill companies

[experience psychology 4th edition ebook pdf collegepdf](#) - Apr 11 2023

web experience psychology 4th edition ebook pdf add a review 95 00 13 00 ebook details author laura king file size 88 mb format pdf length 672 pages publisher mcgraw hill higher education 4th edition publication date january 5 2018 language english asin b07g3cdj5x isbn 10 1260397106 1259911039 126054852x

experience psychology kindle edition by king laura a health - Apr 30 2022

web sep 21 2021 experience psychology kindle edition by king laura a download it once and read it on your kindle device pc phones or tablets use features like bookmarks note taking and highlighting while reading experience psychology

king experience psychology 4th edition anyone got pdf - Dec 07 2022

web mar 18 2020 any chance still have this book i desperately need it 1 stinkyspidey 8 mo ago if u still have the pdf can u pls send lol 1 diufoem 8 mo ago guess who else needs this pdf triplesheepiesupreme 8 mo ago

[experience psychology 4th edition pdf free download](#) - Jan 08 2023

web this experience psychology 4th edition pdf free download was either uploaded by our users live pdf or it must be readily available on various places on public domains and in fair use format as free download use for education proposal

experience psychology laura king download on z library - Jun 13 2023

web informed by student data experience psychology helps students understand and appreciate psychology as an integrated whole the personalized adaptive learning program thought provoking examples and interactive assessments help students see psychology in the world around them and experience it in everyday life

experience psychology laura king pdf download free - Jun 01 2022

web right here we have countless book experience psychology laura king pdf download free and collections to check out we additionally come up with the money for variant types and moreover type of the books to browse

[experience psychology king laura a laura ann free download](#) - Dec 27 2021

web experience psychology by king laura a laura ann publication date 2013 topics psychology publisher new york ny mcgraw hill

experience psychology laura king google books - Feb 09 2023

web oct 5 2009 experience psychology is a first its groundbreaking adaptive questioning diagnostic and personalized study plan help students know what they know while guiding them to experience and learn what they don t know through engaging interactivities exercises and readings

experience psychology laura king google books - May 12 2023

web jul 26 2013 do you want your students to just take psychology or to experience psychology experience psychology is a complete learning system that empowers students to personally critically and

pdf experience psychology laura a king pdf download free book - Aug 03 2022

web download experience psychology full version laura a king pdf experience psychology full collection free online

experience psychology download online experience psychology book read online free experience psychology experience

psychology laura a king pdf book pdf experience psychology pdf laura a king

experience psychology laura king free pdf download minedit - Jul 02 2022

web apr 13 2023 experience psychology laura king free pdf download april 13 2023 posted by jaydon hoover 13 apr

experience psychology laura king free pdf download thanks for visiting minedit if you have any questions about this pdf feel

free to leave a comment in the comment section below for dmca requests please email

experience psychology laura king free download laura king pdf - Feb 26 2022

web experience psychology laura a king 2018 06 resource added for the psychology includes sociology 108091 courses

cambridge handbook of psychology health and medicine susan ayers 2007 08 23 health psychology is a rapidly expanding

discipline at the interface of psychology and clinical medicine this new edition is fully reworked and

[experience psychology by laura a king goodreads](#) - Mar 30 2022

web nov 4 2009 experience psychology places the science of psychology and the research that helps students see the

academic underpinnings at the forefront of the course and at the same time offers an abundance of applications that helps

students connect the science of psychology to the world around them

experience psychology laura king free pdf download pdf pdf - Jan 28 2022

web experience psychology laura king free pdf download pdf upload donald d ferguson 2 3 downloaded from voto uncal edu

br on august 16 2023 by donald d ferguson regression and correlation chapter 13 f distribution and one way anova the glass

castle jeannette walls 2007 01 02 a triumphant tale of a young woman and

does anyone have a pdf of experience psychology by laura king reddit - Oct 05 2022

web jul 7 2019 does anyone have a pdf of experience psychology by laura king 4th edition here s the isbn 9781259911033 it

d really appreciate it if someone had a pdf of this one

experience psychology mcgraw hill - Mar 10 2023

web download the free readanywhere app for offline and mobile access note connect access not included if connect is

required for your course click the connect tab watch to learn more about the ebook 54 00 get it by today sep 4

recorder karate primary 3 ministry of education - Apr 13 2023

web as perspicacity of this recorder karate english edition can be taken as with ease as picked to act recorder karate english edition 2019 10 03 saunders mckenzie

recorder karate teaching resources teachers pay teachers - Sep 06 2022

web 2 hours ago asa featherstone iv for the wall street journal by julie wernau nov 20 2023 9 00 am et santana de labay a 29 year old republican with six children thinks

bulletin board for recorder karate teaching resources tpt - Dec 09 2022

web the karate belt method can be used for any classroom instrument unit to motivate students to practice this is the free version of my recorder karate recorder dojo certificates

what is recorder karate international school blog - Nov 08 2022

web 10 hours ago the india australia cricket world cup final match on sunday created record peak viewership crossing 5 9 crore mark despite the host nation ending on the losing

recorder dojo log in to play along - Mar 12 2023

web 3 50 pdf celebrate your students accomplishments with this fast easy ready to use convenient recorder karate wall of fame posters teachers can use this resource to

recorder karate english edition e journal stp ipi ac id - Jan 10 2023

web oct 22 2023 recorder karate english edition essential elements for recorder classroom method student book 1 kaye clements 2009 09 essential elements

recorder karate bulletin board teaching resources tpt - Jul 04 2022

web aug 27 2023 recorder karate english edition 2 9 downloaded from uniport edu ng on august 27 2023 by guest federation and has been the chairman of the martial arts

recorder karate kindle edition by shammias anna guiza - Feb 11 2023

web jan 29 2017 recorder karate is a self paced recorder instruction method that teaches basic techniques used in wind instruments through nine folk songs in addition students

recorder karate pdf pdf document - Oct 19 2023

web jan 21 2015 the five most common recorders are sopranino ordescant soprano alto tenor and bass the smallest is the garklein recorder which is only four inches long the

recorder karate english edition kindle edition amazon nl - Oct 27 2021

recorder karate songs and belts for elementary music - Jul 16 2023

web product detail recorder karate 1 music k 8 song recorder karate 1 from plank road publishing by barb philipak a highly

motivational method for young players if you re

[recorder karate english edition uniport edu ng](#) - Feb 28 2022

web 2 days ago chart another university de montfort in leicester paid 17 1m in commission to agents last year up from 10 5m in 2021 22 the payments related to 4 457

product detail recorder karate 1 music k 8 - May 14 2023

web sep 12 2012 recorder karate kindle edition by shammass anna guiza victor download it once and read it on your kindle device pc phones or tablets use features

[support for abortion access is near record wsj norc poll finds](#) - Jun 03 2022

web may 13 2023 recorder karate english edition 1 8 downloaded from uniport edu ng on may 13 2023 by guest recorder karate english edition this is likewise one of the

cricket world cup australia wins record extending sixth cnn - Dec 29 2021

web national karate archway melodies teaching resources teachers pay teachers recorder karate co uk shammass anna e books 30 best recorder karate images recorder karate

[recorder karate english edition kindle edition amazon nl](#) - Aug 17 2023

web recorder karate english edition by anna e shammass karate linkedin slideshare may 27th 2020 karate 1 karate the best way of self defence 2 introduction it is a japanese

recorder karate english edition ead3 archivists org - Oct 07 2022

web recorder karate bulletin board teaching resources tpt results for recorder karate bulletin board 44 results sort by relevance view list recorder karate wall of

india aus world cup final match creates record peak viewership of - Aug 05 2022

web the recorder karate bulletin board builder 12 character prints by plank road publishing jan 1 2015 teacher dvd rom 20th anniversary edition by will schmid

[recorder karate english edition uniport edu ng](#) - Jan 30 2022

web recorder karate english edition ebook shammass anna guiza victor amazon nl kindle store

recorder karate english edition by anna e shammass - Sep 25 2021

[uk universities paying millions in agent fees to secure](#) - Nov 27 2021

recorder karate english edition uniport edu ng - Apr 01 2022

web nov 18 2023 australia won a record extending sixth men s cricket world cup on sunday defying the odds and a partisan

home crowd in ahmedabad to defeat host nation india

amazon com recorder karate - May 02 2022

web oct 6 2023 recorder karate english edition 1 1 downloaded from uniport edu ng on october 6 2023 by guest recorder

karate english edition right here we have

recorder karate english edition by anna e shammass - Jun 15 2023

web recorder karate motivates students to achieve their musical goals gives them a sense of achievement and builds their confidence in their first year of learning to play the

recorder karate level 1 pdf google drive - Sep 18 2023

web recorder karate english edition ebook shammass anna e amazon nl kindle store