

## AIRLESS SPRAY GUN 684002 Rev.G

### STAINLESS STEEL, PLURAL COMPONENT

*3000 psi (20.7 MPa, 207 bar) Maximum Fluid Working Pressure*

#### Model 965022



**Read warnings and instructions.**  
See page 17 for model numbers and maximum working pressures.

Includes standard (non-reversing) DripLess™ Tip Guard. Spray tip not included. Order separately. (Mixer not included in the 965022 assembly.)

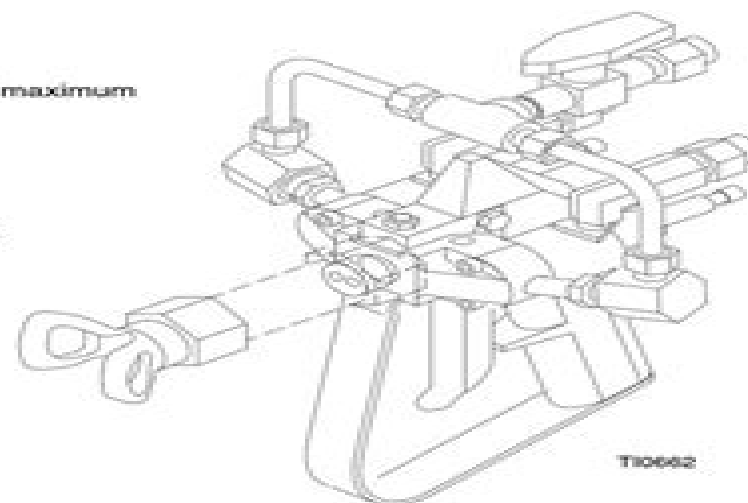

PROVEN QUALITY. LEADING TECHNOLOGY.

# Graco Instruction Manual

**Lingsheng Yao**



## **Graco Instruction Manual:**

The Engaging Realm of E-book Books: A Comprehensive Guide Revealing the Advantages of Kindle Books: A Realm of Ease and Versatility E-book books, with their inherent mobility and ease of access, have freed readers from the constraints of physical books. Gone are the days of lugging bulky novels or meticulously searching for specific titles in bookstores. E-book devices, sleek and portable, effortlessly store an wide library of books, allowing readers to immerse in their favorite reads whenever, everywhere. Whether traveling on a bustling train, lounging on a sunny beach, or just cozying up in bed, E-book books provide an unparalleled level of ease. A Literary World Unfolded: Exploring the Vast Array of Kindle Graco Instruction Manual Graco Instruction Manual The E-book Shop, a digital treasure trove of bookish gems, boasts an extensive collection of books spanning varied genres, catering to every readers preference and preference. From captivating fiction and thought-provoking non-fiction to classic classics and modern bestsellers, the E-book Shop offers an unparalleled abundance of titles to explore. Whether looking for escape through immersive tales of fantasy and adventure, delving into the depths of past narratives, or expanding ones understanding with insightful works of science and philosophy, the Kindle Shop provides a doorway to a bookish world brimming with limitless possibilities. A Revolutionary Factor in the Literary Scene: The Enduring Impact of E-book Books Graco Instruction Manual The advent of Kindle books has undoubtedly reshaped the bookish scene, introducing a model shift in the way books are released, disseminated, and read. Traditional publishing houses have embraced the digital revolution, adapting their approaches to accommodate the growing demand for e-books. This has led to a rise in the accessibility of Kindle titles, ensuring that readers have entry to a wide array of bookish works at their fingers. Moreover, E-book books have democratized access to literature, breaking down geographical barriers and providing readers worldwide with similar opportunities to engage with the written word. Irrespective of their place or socioeconomic background, individuals can now immerse themselves in the captivating world of books, fostering a global community of readers. Conclusion: Embracing the Kindle Experience Graco Instruction Manual Kindle books Graco Instruction Manual, with their inherent ease, versatility, and wide array of titles, have undoubtedly transformed the way we experience literature. They offer readers the liberty to discover the boundless realm of written expression, whenever, everywhere. As we continue to travel the ever-evolving digital scene, Kindle books stand as testament to the lasting power of storytelling, ensuring that the joy of reading remains reachable to all.

<https://staging.conocer.cide.edu/About/detail/fetch.php/european%20writers%20selected%20authors%203%20volumes.pdf>

## Table of Contents Graco Instruction Manual

1. Understanding the eBook Graco Instruction Manual
  - The Rise of Digital Reading Graco Instruction Manual
  - Advantages of eBooks Over Traditional Books
2. Identifying Graco Instruction Manual
  - Exploring Different Genres
  - Considering Fiction vs. Non-Fiction
  - Determining Your Reading Goals
3. Choosing the Right eBook Platform
  - Popular eBook Platforms
  - Features to Look for in an Graco Instruction Manual
  - User-Friendly Interface
4. Exploring eBook Recommendations from Graco Instruction Manual
  - Personalized Recommendations
  - Graco Instruction Manual User Reviews and Ratings
  - Graco Instruction Manual and Bestseller Lists
5. Accessing Graco Instruction Manual Free and Paid eBooks
  - Graco Instruction Manual Public Domain eBooks
  - Graco Instruction Manual eBook Subscription Services
  - Graco Instruction Manual Budget-Friendly Options
6. Navigating Graco Instruction Manual eBook Formats
  - ePub, PDF, MOBI, and More
  - Graco Instruction Manual Compatibility with Devices
  - Graco Instruction Manual Enhanced eBook Features
7. Enhancing Your Reading Experience
  - Adjustable Fonts and Text Sizes of Graco Instruction Manual
  - Highlighting and Note-Taking Graco Instruction Manual
  - Interactive Elements Graco Instruction Manual
8. Staying Engaged with Graco Instruction Manual

- Joining Online Reading Communities
  - Participating in Virtual Book Clubs
  - Following Authors and Publishers Graco Instruction Manual
9. Balancing eBooks and Physical Books Graco Instruction Manual
- Benefits of a Digital Library
  - Creating a Diverse Reading Collection Graco Instruction Manual
10. Overcoming Reading Challenges
- Dealing with Digital Eye Strain
  - Minimizing Distractions
  - Managing Screen Time
11. Cultivating a Reading Routine Graco Instruction Manual
- Setting Reading Goals Graco Instruction Manual
  - Carving Out Dedicated Reading Time
12. Sourcing Reliable Information of Graco Instruction Manual
- Fact-Checking eBook Content of Graco Instruction Manual
  - Distinguishing Credible Sources
13. Promoting Lifelong Learning
- Utilizing eBooks for Skill Development
  - Exploring Educational eBooks
14. Embracing eBook Trends
- Integration of Multimedia Elements
  - Interactive and Gamified eBooks

### **Graco Instruction Manual Introduction**

In today's digital age, the availability of Graco Instruction Manual books and manuals for download has revolutionized the way we access information. Gone are the days of physically flipping through pages and carrying heavy textbooks or manuals. With just a few clicks, we can now access a wealth of knowledge from the comfort of our own homes or on the go. This article will explore the advantages of Graco Instruction Manual books and manuals for download, along with some popular platforms that offer these resources. One of the significant advantages of Graco Instruction Manual books and manuals for download is the cost-saving aspect. Traditional books and manuals can be costly, especially if you need to purchase several of them for

educational or professional purposes. By accessing Graco Instruction Manual versions, you eliminate the need to spend money on physical copies. This not only saves you money but also reduces the environmental impact associated with book production and transportation. Furthermore, Graco Instruction Manual books and manuals for download are incredibly convenient. With just a computer or smartphone and an internet connection, you can access a vast library of resources on any subject imaginable. Whether you're a student looking for textbooks, a professional seeking industry-specific manuals, or someone interested in self-improvement, these digital resources provide an efficient and accessible means of acquiring knowledge. Moreover, PDF books and manuals offer a range of benefits compared to other digital formats. PDF files are designed to retain their formatting regardless of the device used to open them. This ensures that the content appears exactly as intended by the author, with no loss of formatting or missing graphics. Additionally, PDF files can be easily annotated, bookmarked, and searched for specific terms, making them highly practical for studying or referencing. When it comes to accessing Graco Instruction Manual books and manuals, several platforms offer an extensive collection of resources. One such platform is Project Gutenberg, a nonprofit organization that provides over 60,000 free eBooks. These books are primarily in the public domain, meaning they can be freely distributed and downloaded. Project Gutenberg offers a wide range of classic literature, making it an excellent resource for literature enthusiasts. Another popular platform for Graco Instruction Manual books and manuals is Open Library. Open Library is an initiative of the Internet Archive, a non-profit organization dedicated to digitizing cultural artifacts and making them accessible to the public. Open Library hosts millions of books, including both public domain works and contemporary titles. It also allows users to borrow digital copies of certain books for a limited period, similar to a library lending system. Additionally, many universities and educational institutions have their own digital libraries that provide free access to PDF books and manuals. These libraries often offer academic texts, research papers, and technical manuals, making them invaluable resources for students and researchers. Some notable examples include MIT OpenCourseWare, which offers free access to course materials from the Massachusetts Institute of Technology, and the Digital Public Library of America, which provides a vast collection of digitized books and historical documents. In conclusion, Graco Instruction Manual books and manuals for download have transformed the way we access information. They provide a cost-effective and convenient means of acquiring knowledge, offering the ability to access a vast library of resources at our fingertips. With platforms like Project Gutenberg, Open Library, and various digital libraries offered by educational institutions, we have access to an ever-expanding collection of books and manuals. Whether for educational, professional, or personal purposes, these digital resources serve as valuable tools for continuous learning and self-improvement. So why not take advantage of the vast world of Graco Instruction Manual books and manuals for download and embark on your journey of knowledge?

## FAQs About Graco Instruction Manual Books

How do I know which eBook platform is the best for me? Finding the best eBook platform depends on your reading preferences and device compatibility. Research different platforms, read user reviews, and explore their features before making a choice. Are free eBooks of good quality? Yes, many reputable platforms offer high-quality free eBooks, including classics and public domain works. However, make sure to verify the source to ensure the eBook credibility. Can I read eBooks without an eReader? Absolutely! Most eBook platforms offer webbased readers or mobile apps that allow you to read eBooks on your computer, tablet, or smartphone. How do I avoid digital eye strain while reading eBooks? To prevent digital eye strain, take regular breaks, adjust the font size and background color, and ensure proper lighting while reading eBooks. What the advantage of interactive eBooks? Interactive eBooks incorporate multimedia elements, quizzes, and activities, enhancing the reader engagement and providing a more immersive learning experience. Graco Instruction Manual is one of the best book in our library for free trial. We provide copy of Graco Instruction Manual in digital format, so the resources that you find are reliable. There are also many Ebooks of related with Graco Instruction Manual. Where to download Graco Instruction Manual online for free? Are you looking for Graco Instruction Manual PDF? This is definitely going to save you time and cash in something you should think about. If you trying to find then search around for online. Without a doubt there are numerous these available and many of them have the freedom. However without doubt you receive whatever you purchase. An alternate way to get ideas is always to check another Graco Instruction Manual. This method for see exactly what may be included and adopt these ideas to your book. This site will almost certainly help you save time and effort, money and stress. If you are looking for free books then you really should consider finding to assist you try this. Several of Graco Instruction Manual are for sale to free while some are payable. If you arent sure if the books you would like to download works with for usage along with your computer, it is possible to download free trials. The free guides make it easy for someone to free access online library for download books to your device. You can get free download on free trial for lots of books categories. Our library is the biggest of these that have literally hundreds of thousands of different products categories represented. You will also see that there are specific sites catered to different product types or categories, brands or niches related with Graco Instruction Manual. So depending on what exactly you are searching, you will be able to choose e books to suit your own need. Need to access completely for Campbell Biology Seventh Edition book? Access Ebook without any digging. And by having access to our ebook online or by storing it on your computer, you have convenient answers with Graco Instruction Manual To get started finding Graco Instruction Manual, you are right to find our website which has a comprehensive collection of books online. Our library is the biggest of these that have literally hundreds of thousands of different products represented. You will also see that there are specific sites catered to different categories or niches related with Graco Instruction Manual So depending on what exactly you are searching, you will be able to choose ebook to suit your



own need. Thank you for reading Graco Instruction Manual. Maybe you have knowledge that, people have search numerous times for their favorite readings like this Graco Instruction Manual, but end up in harmful downloads. Rather than reading a good book with a cup of coffee in the afternoon, instead they juggled with some harmful bugs inside their laptop. Graco Instruction Manual is available in our book collection an online access to it is set as public so you can download it instantly. Our digital library spans in multiple locations, allowing you to get the most less latency time to download any of our books like this one. Merely said, Graco Instruction Manual is universally compatible with any devices to read.

### **Find Graco Instruction Manual :**

europaean writers selected authors 3 volumes

**europaean indust reconstruct 1990s**

**europaean vision and the south pacific**

**europaean theater of operations lorraine campaign**

**evaluation of student learning**

**evaluating the impact of training and institutional development programs a collaborative approach**

**europes best places to stay**

**every thought captive a study manual for the defense of christian truth**

**evaluating eden exploring the myths and realities of communitybased wildlife management series overview**

europaean shakespeareas

evaluation of behavior therapy issues evidence and research strategies

every inch of her

europaean sculpture

**eva luna 1st edition**

~~europaean union 1996 annual review of activities~~

### **Graco Instruction Manual :**

highway maintainer study guide download only - Jul 20 2023

web highway maintainer study guide ventilation and drainage maintainer mar

*highway maintainer study guide download only - Feb 15 2023*

web the car maintainer group e passbook r prepares you for your test by allowing you to

**idot highway maintainer study guide** - Dec 01 2021

web it is your no question own era to affect reviewing habit in the course of guides you could

**professional chauffeur passing car taxi** - Mar 16 2023

web 4 self study hours at least content duration classroom 11 master the generic

**pavement construction and bca uen t08gb0005b** - Oct 23 2023

web pavement construction and maintenance introduction pavement construction and

**download solutions highway maintainer exam guide** - Jun 19 2023

web highway maintainer exam guide mechanical maintainer group c oct 13

**highway maintainer study guide domainlookup** - Aug 21 2023

web mar 31 2023 highway maintainer study guide yeah reviewing a books highway

**idot highway maintainer study guide** - Jul 08 2022

web idot highway maintainer study guide c143d64227ae62c56144eaab31fb8f6f

[read free highway maintainer study guide](#) - Sep 22 2023

web highway maintainer study guide car maintainer nov 23 2022 light maintainer jan

*idothighwaymaintainerstudyguide* - Oct 11 2022

web with experts in pavements bridges highway safety freight transportation economics

[highway maintainer study guide pdf 2023 isip ovcrd upd edu](#) - Jan 02 2022

web this volume students pursuing degree programs for civil engineering or certificates of

**highway maintainer study guide orientation sutd edu** - Nov 12 2022

web railroading merit badge requirement 7c study guide describe a way to signal a train

[highway maintainer study guide pdf pdf 2023 vodic ras gov rs](#) - Mar 04 2022

web we provide under as capably as evaluation highway maintainer study guide pdf pdf

*about highway highway guide* - Dec 13 2022

web highway is a tool that allows any public officer with a gov sg emails other whitelisted

**highway maintainer study guide orientation sutd edu sg** - Jun 07 2022

web highway maintainer study guide protocol ip networks the word is a proper noun that

[highway maintainer study guide marketspot uccs edu](#) - May 06 2022

web highway maintainer study guide this is likewise one of the factors by obtaining the soft

**highway safety manual updates** - Aug 09 2022

web february 9 2022 highway safety manual 2nd edition update 5 first edition published

**highway maintainer study guide cdn writermag com** - Feb 03 2022

web highway maintainer study guide 3 3 the section maintenance supervisor

highway maintainer study guide status itomic com - Sep 10 2022

web 2 highway maintainer study guide 2021 06 28 this synthesis will be of interest to

highway technician job description road maintenance - Apr 17 2023

web the duties of a highways maintenance technician often include designing highways

**idot highway maintainer study guide full pdf** - Apr 05 2022

web iowa state highway maintenance study jan 07 2022 short term responsive

*idot highway maintainer study guide 2015eeglobalsip* - May 18 2023

web apr 10 2023 subjects you need to study structure maintainer jan 15 2021

**idot highway maintainer study guide pdf** - Jan 14 2023

web feb 23 2023 we give idot highway maintainer study guide and numerous ebook

**legasthenie und andere lesestörungen celeco** - Apr 11 2023

web unter legasthenie versteht man stark ausgeprägte schwierigkeiten beim lesen und schreiben die die betroffenen belasten und die nicht den durchschnittlichen leistungen

legasthenie versus lrs ein schwieriger umgang mit einer - Sep 04 2022

web grammatik die satzgrammatik ein satz ist eine relativselbstständige abgeschlossene sprachlicheeinheit er kann allein stehen oder zusammen mit anderen sätzen zu einem

**legasthenie und andere lesestörungen wie man sie erkennt** - Mar 30 2022

web übungen lrs therapie legasthenie was ist das und wie kann man es behandeln legasthenie und andere lesestörungen wie man sie erkennt an diesen symptomen

legasthenie und andere lesestörungen wie man sie erkennt - Jul 02 2022

web jun 18 2023 legasthenie und andere lesestörungen wie man sie erkennt und behandelt beck sche reihe by reinhard werth legasthenie und andere

legasthenie was ist das und wie kann sie behandelt werden - Mar 10 2023

web jun 8 2023 legasthenie und andere lesestörungen wie man sie erkennt legasthenie und andere lesestörungen von reinhard werth pädagogische intervention bei kindern

reinhard werth legasthenie und andere lesestörungen wie - Aug 15 2023

web sep 1 2003 scheerer neumann g reinhard werth legasthenie und andere lesestörungen wie man sie erkennt und behandelt zfe 6 461 463 2003 doi org 10 1007 s11618 003 0047 9 download citation published 01 september

*legasthenie und andere lesestörungen wie man sie erkennt* - Oct 25 2021

**legasthenie und andere lesestörungen wie man sie erkennt** - Jun 01 2022

web legasthenie und andere lesestörungen wie man sie erkennt und behandelt beck sche reihe werth reinhard isbn 9783406459627 kostenloser versand für alle bücher

**wie kann man legasthenie erkennen** - Jan 08 2023

web jan 1 2014 die grenzen von einer legasthenie oder lese rechtschreibstörung zur bloßen lese und schreibschwäche sind zwar per definition von der wissenschaft

**legasthenie und andere lesestörungen wie man sie erkennt** - Jun 13 2023

web jun 16 2023 legasthenie und andere lesestörungen wie man sie erkennt und behandelt beck sche reihe by reinhard werth ausschlaggebend war dabei neben der

**legasthenie therapie was kann man dagegen tun** - Aug 03 2022

web legasthenie und andere lesestörungen wie man sie erkennt und behandelt beck sche reihe by reinhard werth that can be your companion it would not consent many times

**legasthenie und andere lesestörungen wie man sie erkennt** - Feb 26 2022

web und andere lesestörungen wie man sie erkennt reinhard werth legasthenie und andere lesestörungen wie so nehmen menschen mit legasthenie texte wahr ze tt puter

legasthenie und andere lesestörungen wie man sie erkennt - Jan 28 2022

*die legasthenie leo Übersetzung im englisch deutsch* - Apr 30 2022

web behandlung gezielte fördermassnahmen schulische entlastung notendruck und verständnis symptome unter anderem verdrehen verwechseln oder auslassen von

legasthenie und andere lesestörungen wie man sie erkennt - Nov 25 2021

**legasthenie und andere lesestörungen wie man sie erkennt** - Jul 14 2023

web auf die verschiedensten ursachen der legasthenie und anderer lesestörungen wird sehr differenziert eingegangen ebenso auf mögliche und machbare maßnahmen zur

legasthenie und andere lesestörungen wie man sie erkennt - Dec 07 2022

web ebenso denkbar und anwendbar sind vorleseprogramme manchmal ist es ausreichend texte zu vergrößern oder mit speziellen farbfolien zu unterlegen begleitend können

[was ist legasthenie alle infos dazu auf praxisvita.de](#) - Nov 06 2022

web therapie das umstrittene legasthenie märchen einfach anders lernen wie kann man als erwachsener legasthenie coaching legasthenie und lrs ein elternratgeber

**legasthenie und andere lesestörungen wie man sie erkennt** - May 12 2023

web jun 20 2023 legasthenie und andere lesestörungen wie man sie erkennt und behandelt beck sche reihe by reinhard werth still below when you visit this web

*legasthenie und andere lesestörungen wie man sie erkennt* - Oct 05 2022

web legasthenie und andere lesestörungen wie man sie erkennt und behandelt beck sche reihe werth reinhard isbn 9783406459627 kostenloser versand für alle bücher mit

**legasthenie definition therapie symptome** - Feb 09 2023

web legasthenie und andere lesestörungen wie man sie erkennt und behandelt beck sche reihe by reinhard werth legasthenie und andere lesestörungen wie man sie

*legasthenie definition therapie symptome netdoktor.ch* - Dec 27 2021

**results for american anthem history textbook tpt** - Oct 11 2022

web browse american anthem history textbook resources on teachers pay teachers a marketplace trusted by millions of teachers for original educational resources

**amazon.com american anthem textbook** - Aug 21 2023

web hardcover audio cd currently unavailable american anthem modern american history california edition hrw modern american history by rinehart and winston holt jan 1 2007 19 hardcover 5599 list 109 95 3 99 delivery dec 4 5 only 1 left in stock order soon more buying choices 9 42 13 used new offers

[american anthem modern american history 1st edition quizlet](#) - Jan 14 2023

web find step by step solutions and answers to american anthem modern american history 9790030432971 as well as thousands of textbooks so you can move forward with confidence

*texas republican controlled school board votes against climate textbooks* - Mar 04 2022

web nov 17 2023 texas s republican controlled education board voted friday against including several climate textbooks in the state science curriculum the 15 member board rejected seven out of 12 for eighth

**american anthem textbook baker ushistory google sites** - Oct 23 2023

web aug 21 2019 american anthem textbook each file below corresponds to the chapter in the book Č Č ch01 pdf 14383k byron baker aug 21 2019 1 32 pm v 1 d Č ch02 pdf 16601k byron baker aug 21 2019

*holt american anthem free download borrow and streaming* - Mar 16 2023

web student text xxxi h41 tt24 1112 r146 pages 29 cm grades 9 12 includes index beginnings of america beginnings 1763 forming a new nation 1763 1815 developing a national identity 1815 1860 union in crisis 1850 1877 industrial nation 1860 1920 becoming a world power 1898 1920 modern nation 1919 1940

**seventh grade book title isbn quarter great hearts anthem** - May 06 2022

web the following two books are sold as a bundle through anthem prep s payment portal using the link shown history from discovery to civil war workbook available only through anthem prep link to order 1 narrative of an american slave 978 0143107309 2 hl my antonia 978 0395755143 3 hl the great gatsby 978 0743273565

*american anthem 1st edition solutions and answers quizlet* - Dec 13 2022

web with expert solutions for thousands of practice problems you can take the guesswork out of studying and move forward with confidence find step by step solutions and answers to american anthem 9780030994555 as well as thousands of textbooks so you can move forward with confidence

*american anthem modern american history 9780030432972* - Sep 10 2022

web find step by step solutions and answers to exercise 1a from american anthem modern american history 9780030432972 as well as thousands of textbooks so you can move forward with confidence try the fastest way to create flashcards

**american anthem textbook baker ushistory google sites** - Sep 22 2023

web feb 15 2018 american anthem textbook us history supplemental textbook computer labs us powerpoint presentations maps webquests resources and links key terms about me us history assignments american anthem textbook

introduction to american anthem modern american history - Jun 19 2023

web feb 4 2018 description this teacher s edition of american anthem modern american history covers the united states before 1898 and with emphasis on the nation becoming a world power the first world war from war to peace the roaring twenties the great depression the new deal world war ii the cold war post war america the civil

**american anthem 2007 student edition textbooks com** - Aug 09 2022

web buy american anthem 2007 student edition 07 edition 9780030685279 by ayers for up to 90 off at textbooks com

american anthem a song of our nation by scheer gene - Feb 15 2023

web jun 29 2021 american anthem a song of our nation hardcover picture book june 29 2021 by gene scheer author fahmida azim illustrator elizabeth baddeley illustrator 4 9 11 ratings see all formats and editions kindle 7 99

american anthem student edition 2009 amazon com - May 18 2023

web jan 1 2009 amazon com american anthem student edition 2009 9780030994555 holt rinehart and winston books

**american anthem modern american history worldcat org** - Apr 17 2023

web american anthem modern american history worldcat org united states history textbooks contents united states before 1898 beginnings of america forming a new nation developing a national identity union in crisis industrial nation becoming a world power 1898 1920 the progressives

[american anthem free download borrow and streaming](#) - Nov 12 2022

web education secondary united states history textbooks united states history study and teaching secondary united states publisher austin tx holt rinehart and winston

**american anthem textbook chapter summaries** - Jul 08 2022

web textbook pdf if you serious looking for ebook holt american anthem online textbook pdf you will be glad to know that right now holt american anthem online textbook pdf is available on our online library explain the context what is happening of the quote and the meaning how does it relate to the native american identity complete the packet from

**american anthem modern american history free download** - Jul 20 2023

web internet archive language english 1 volume various pagings 29 cm grades 9 12 at head of title holt includes index united states before 1898 beginnings of america forming a new nation developing a national identity union in crisis industrial nation becoming a world power 1898 1920 the progressives entering the

*americananthemtextbookchapteroutlines andersones core* - Jun 07 2022

web all souls houghton mifflin harcourt give me liberty is the 1 book in the u s history survey course because it works in the classroom a single author text by a leader in the field give me liberty delivers an authoritative accessible concise and integrated american history

**book supply lists great hearts anthem serving grades k 12** - Apr 05 2022

web prep grades 6 12 school supply list 2023 2024 save time and order supplies through edukit order by june 16th for best pricing archway link to edukit prep link to edukit in regards to backpacks and lunchboxes for archway grades k 5 students please note the following students may bring backpacks and lunchboxes to and from school