

Gear Box Assembly

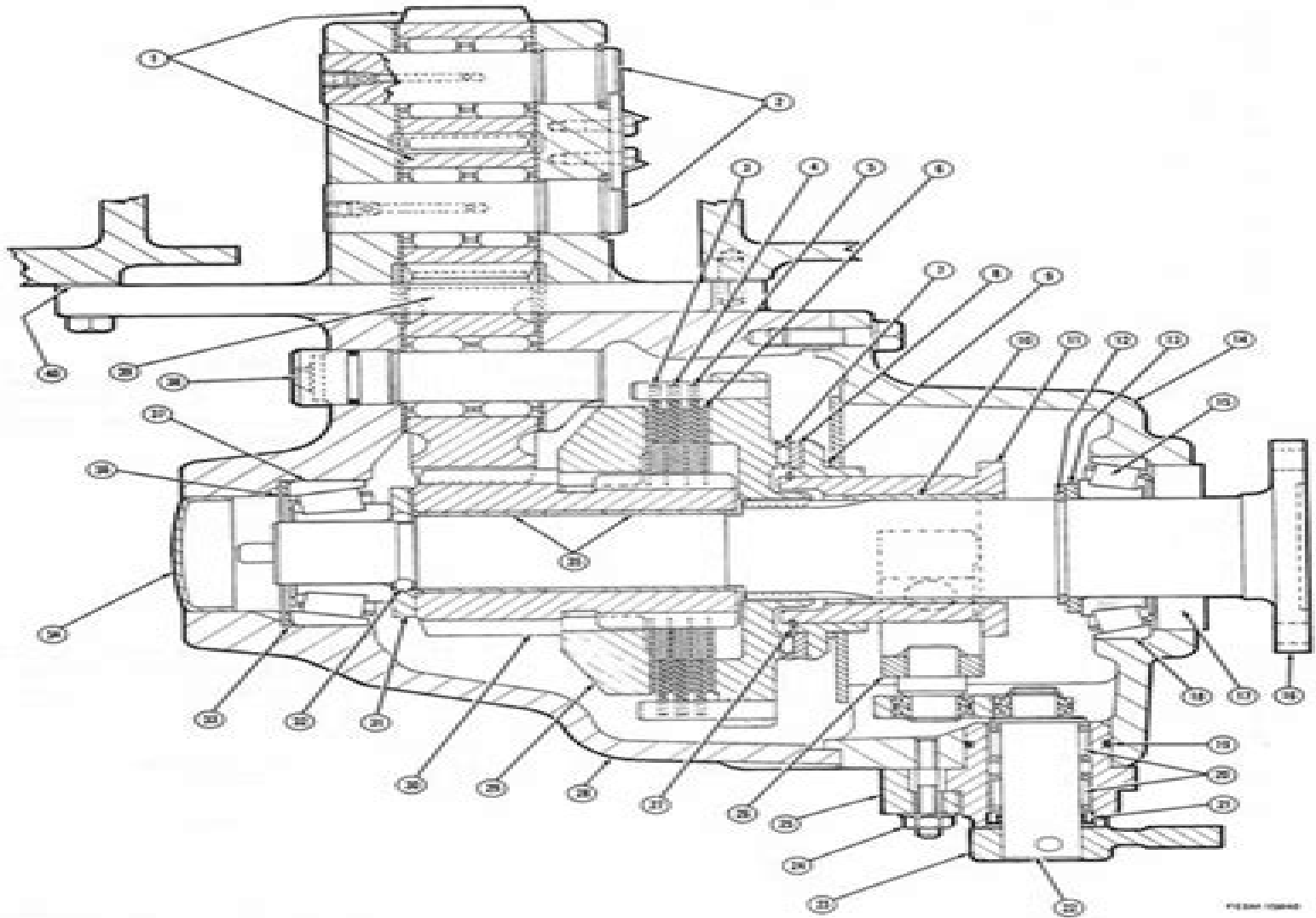

Ih 45engine Diagram

Didier Musso



Ih 45engine Diagram:

Unveiling the Power of Verbal Art: An Psychological Sojourn through **Ih 45engine Diagram**

In a global inundated with screens and the cacophony of quick communication, the profound energy and emotional resonance of verbal beauty often fade in to obscurity, eclipsed by the constant onslaught of noise and distractions. Yet, set within the lyrical pages of **Ih 45engine Diagram**, a charming function of literary beauty that impulses with raw thoughts, lies an memorable journey waiting to be embarked upon. Written by a virtuoso wordsmith, this interesting opus manuals visitors on a mental odyssey, delicately revealing the latent potential and profound influence stuck within the complicated web of language. Within the heart-wrenching expanse of this evocative evaluation, we will embark upon an introspective exploration of the book is main themes, dissect its charming writing style, and immerse ourselves in the indelible impression it leaves upon the depths of readers souls.

<https://staging.conocer.cide.edu/data/Resources/fetch.php/Mendelian%20Genetics%20Of%20Corn%20Kit%20Carolina%20Answers.pdf>

Table of Contents Ih 45engine Diagram

1. Understanding the eBook Ih 45engine Diagram
 - The Rise of Digital Reading Ih 45engine Diagram
 - Advantages of eBooks Over Traditional Books
2. Identifying Ih 45engine Diagram
 - Exploring Different Genres
 - Considering Fiction vs. Non-Fiction
 - Determining Your Reading Goals
3. Choosing the Right eBook Platform
 - Popular eBook Platforms
 - Features to Look for in an Ih 45engine Diagram
 - User-Friendly Interface
4. Exploring eBook Recommendations from Ih 45engine Diagram

- Personalized Recommendations
 - Ih 45engine Diagram User Reviews and Ratings
 - Ih 45engine Diagram and Bestseller Lists
5. Accessing Ih 45engine Diagram Free and Paid eBooks
 - Ih 45engine Diagram Public Domain eBooks
 - Ih 45engine Diagram eBook Subscription Services
 - Ih 45engine Diagram Budget-Friendly Options
 6. Navigating Ih 45engine Diagram eBook Formats
 - ePub, PDF, MOBI, and More
 - Ih 45engine Diagram Compatibility with Devices
 - Ih 45engine Diagram Enhanced eBook Features
 7. Enhancing Your Reading Experience
 - Adjustable Fonts and Text Sizes of Ih 45engine Diagram
 - Highlighting and Note-Taking Ih 45engine Diagram
 - Interactive Elements Ih 45engine Diagram
 8. Staying Engaged with Ih 45engine Diagram
 - Joining Online Reading Communities
 - Participating in Virtual Book Clubs
 - Following Authors and Publishers Ih 45engine Diagram
 9. Balancing eBooks and Physical Books Ih 45engine Diagram
 - Benefits of a Digital Library
 - Creating a Diverse Reading Collection Ih 45engine Diagram
 10. Overcoming Reading Challenges
 - Dealing with Digital Eye Strain
 - Minimizing Distractions
 - Managing Screen Time
 11. Cultivating a Reading Routine Ih 45engine Diagram
 - Setting Reading Goals Ih 45engine Diagram
 - Carving Out Dedicated Reading Time
 12. Sourcing Reliable Information of Ih 45engine Diagram

- Fact-Checking eBook Content of Ih 45engine Diagram
 - Distinguishing Credible Sources
13. Promoting Lifelong Learning
- Utilizing eBooks for Skill Development
 - Exploring Educational eBooks
14. Embracing eBook Trends
- Integration of Multimedia Elements
 - Interactive and Gamified eBooks

Ih 45engine Diagram Introduction

In today's digital age, the availability of Ih 45engine Diagram books and manuals for download has revolutionized the way we access information. Gone are the days of physically flipping through pages and carrying heavy textbooks or manuals. With just a few clicks, we can now access a wealth of knowledge from the comfort of our own homes or on the go. This article will explore the advantages of Ih 45engine Diagram books and manuals for download, along with some popular platforms that offer these resources. One of the significant advantages of Ih 45engine Diagram books and manuals for download is the cost-saving aspect. Traditional books and manuals can be costly, especially if you need to purchase several of them for educational or professional purposes. By accessing Ih 45engine Diagram versions, you eliminate the need to spend money on physical copies. This not only saves you money but also reduces the environmental impact associated with book production and transportation. Furthermore, Ih 45engine Diagram books and manuals for download are incredibly convenient. With just a computer or smartphone and an internet connection, you can access a vast library of resources on any subject imaginable. Whether you're a student looking for textbooks, a professional seeking industry-specific manuals, or someone interested in self-improvement, these digital resources provide an efficient and accessible means of acquiring knowledge. Moreover, PDF books and manuals offer a range of benefits compared to other digital formats. PDF files are designed to retain their formatting regardless of the device used to open them. This ensures that the content appears exactly as intended by the author, with no loss of formatting or missing graphics. Additionally, PDF files can be easily annotated, bookmarked, and searched for specific terms, making them highly practical for studying or referencing. When it comes to accessing Ih 45engine Diagram books and manuals, several platforms offer an extensive collection of resources. One such platform is Project Gutenberg, a nonprofit organization that provides over 60,000 free eBooks. These books are primarily in the public domain, meaning they can be freely distributed and downloaded. Project Gutenberg offers a wide range of classic literature, making it an excellent resource for literature enthusiasts. Another popular platform for Ih 45engine Diagram books and

manuals is Open Library. Open Library is an initiative of the Internet Archive, a non-profit organization dedicated to digitizing cultural artifacts and making them accessible to the public. Open Library hosts millions of books, including both public domain works and contemporary titles. It also allows users to borrow digital copies of certain books for a limited period, similar to a library lending system. Additionally, many universities and educational institutions have their own digital libraries that provide free access to PDF books and manuals. These libraries often offer academic texts, research papers, and technical manuals, making them invaluable resources for students and researchers. Some notable examples include MIT OpenCourseWare, which offers free access to course materials from the Massachusetts Institute of Technology, and the Digital Public Library of America, which provides a vast collection of digitized books and historical documents. In conclusion, Ih 45engine Diagram books and manuals for download have transformed the way we access information. They provide a cost-effective and convenient means of acquiring knowledge, offering the ability to access a vast library of resources at our fingertips. With platforms like Project Gutenberg, Open Library, and various digital libraries offered by educational institutions, we have access to an ever-expanding collection of books and manuals. Whether for educational, professional, or personal purposes, these digital resources serve as valuable tools for continuous learning and self-improvement. So why not take advantage of the vast world of Ih 45engine Diagram books and manuals for download and embark on your journey of knowledge?

FAQs About Ih 45engine Diagram Books

1. Where can I buy Ih 45engine Diagram books? Bookstores: Physical bookstores like Barnes & Noble, Waterstones, and independent local stores. Online Retailers: Amazon, Book Depository, and various online bookstores offer a wide range of books in physical and digital formats.
2. What are the different book formats available? Hardcover: Sturdy and durable, usually more expensive. Paperback: Cheaper, lighter, and more portable than hardcovers. E-books: Digital books available for e-readers like Kindle or software like Apple Books, Kindle, and Google Play Books.
3. How do I choose a Ih 45engine Diagram book to read? Genres: Consider the genre you enjoy (fiction, non-fiction, mystery, sci-fi, etc.). Recommendations: Ask friends, join book clubs, or explore online reviews and recommendations. Author: If you like a particular author, you might enjoy more of their work.
4. How do I take care of Ih 45engine Diagram books? Storage: Keep them away from direct sunlight and in a dry environment. Handling: Avoid folding pages, use bookmarks, and handle them with clean hands. Cleaning: Gently dust

- the covers and pages occasionally.
5. Can I borrow books without buying them? Public Libraries: Local libraries offer a wide range of books for borrowing. Book Swaps: Community book exchanges or online platforms where people exchange books.
 6. How can I track my reading progress or manage my book collection? Book Tracking Apps: Goodreads, LibraryThing, and Book Catalogue are popular apps for tracking your reading progress and managing book collections. Spreadsheets: You can create your own spreadsheet to track books read, ratings, and other details.
 7. What are Ih 45engine Diagram audiobooks, and where can I find them? Audiobooks: Audio recordings of books, perfect for listening while commuting or multitasking. Platforms: Audible, LibriVox, and Google Play Books offer a wide selection of audiobooks.
 8. How do I support authors or the book industry? Buy Books: Purchase books from authors or independent bookstores. Reviews: Leave reviews on platforms like Goodreads or Amazon. Promotion: Share your favorite books on social media or recommend them to friends.
 9. Are there book clubs or reading communities I can join? Local Clubs: Check for local book clubs in libraries or community centers. Online Communities: Platforms like Goodreads have virtual book clubs and discussion groups.
 10. Can I read Ih 45engine Diagram books for free? Public Domain Books: Many classic books are available for free as they're in the public domain. Free E-books: Some websites offer free e-books legally, like Project Gutenberg or Open Library.

Find Ih 45engine Diagram :

mendelian genetics of corn kit carolina answers

[mens super guide jacket](#)

[mercedes 320s 2000 manual](#)

mercedes 190 d service repair manual

mercedes benz 2015 ml320 owners manual

mercedes benz audio 20 manual

mer cruiser thunderbolt iv ignition diagrams

[memorandum of electrotechnology august 2009 n3](#)

mercedes benz e 240 owners manual

memorandum of tourism pat grade 2014

mercedes benz 2633 owners manual
mercedes benz c class service b
mercedes 300d turbo manual transmission
memorandum of mathematics grade 11 november 2014
~~mep demonstration project practice book y8a~~

Ih 45engine Diagram :

fp9 maj 2009 folkeskoleløsninger i matematik - Apr 05 2022

web længde tre gange diameter af bold 3 2 21 5 mm 129 mm bredde dybde diameter af bold 2 21 5 mm 43 mm kassens rumfang er 129 mm 43 mm 43 mm 238 521 mm³ 238 521 0 1 cm 3 238 521 0 13 cm³ 238 521 0 001 cm³ 238 5 cm³ 3 21 5 mm 3 4π 3 3 2 15 cm 3 4π 3 124 9 cm 3

matematik fsa uvm dk - Dec 13 2022

web matematik fsa pointfordeling matematiske færdigheder hvert rigtigt resultat tildeles 1 point der kan forekomme opgaver hvor flere forskellige resultater kan godkendes som en korrekt besvarelse matematisk problemløsning besvarelser af matematisk problemløsning kan højst tildeles 100 point opgave 1 besøg i eiffeltårnet højst 26 point

fsa matematik problemregning download only - Jan 14 2023

web fsa matematik problemregning kursusmatematik fsa mar 22 2023 the ecology of greenland oct 17 2022 bogmarkedet feb 09 2022 nordisk boghandlertidende mar 10 2022 the melt method enhanced edition apr 11 2022 in this enhanced digital edition of the melt method sue hitzmann shows you how to live without pain

fsa matematik golf matematik opgaver com - Nov 12 2022

web mar 2 2014 søg side 1 af 4 skribentens beskrivelse af fsa matematik golf det er en fsa prøve som jeg skulle lave som aflevering til min lærer den er let og enkel du kan bruge den til at forbedre dit standpunkt eller hvis du bare har fået den for og ikke rigtigt kan finde ud af at udregne et par opgaver så er den her altid en god hjælp

fsa matematik facit maj - Feb 15 2023

web fsa matematik facit maj arithmeticae libri duo geometriae septem et viginti mar 02 2021 petri rami arithmeticae libri duo geometriae septem et viginti sep 27 2020 arithmeticae libri duo may 04 2021 nordisk boghandlertidende dec 11 2021 dansk bogfortegnelse aug 19 2022 opera philosophica quae latine scripsit omnia jun

løsninger til folkeskolens problemregning - Aug 09 2022

web besvarede eksamenssæt og vejledende opgaver i matematik for folkeskolen kontakt gymnasiet og hf løsninger og opgavesæt til folkeskolens 9 10 klasse problemregning for 2016 2022 kan købes i webshoppen for 9 50 kr stykket en samlet

løsning for hvert klasseset kan købes for 30 kr efter købet vil du modtage en email hvorigennem
[grade 8 fsa mathematics workbook 2018 2019 a](#) - Jul 20 2023

web the best book to ace the fsa math exam grade 8 fsa mathematics workbook is full of specific and detailed material that will be key to succeeding on the fsa math it s filled with the critical math concepts a student will need in order to do well on the test

gov sg fsa singapore government directory - Sep 22 2023

web nov 16 2023 faculty of arts and social sciences nus business school school of computing faculty of dentistry college of design and engineering faculty of law yong loo lin school of medicine yong siew toh conservatory of music saw swee hock school of public health

[fsa mathematics workbook for grade 3 step by step guide to](#) - Aug 21 2023

web this book with 2 complete fsa tests is all your student will ever need to fully prepare for the fsa math this workbook includes practice test questions it contains easy to read essential summaries that highlight the key areas of the fsa math test effortless math test study guide reviews the most important components of the fsa math test

[fp9 maj 2011 folkeskoleløsninger i matematik](#) - Jul 08 2022

web middeltallet kan beregnes ved at lægge alle timer sammen for alle elever og dividere med antal elever i den enkelte klasse man får for 9a 1 6 5 4 7 0 3 7 5 8 8 0 5 8 5 2 9 0 1 9 5 1 10 0 25 8 04 for 9b får man 8 05 forskelle variatonsbredde forskel mellem største og mindste værdi for søvn i en

[matematikbanken online opgaver for dygtige fp10 og fp9 elever](#) - Jun 19 2023

web matematik opgaver til fs10 og fsa elever i folkeskolen og efterskolen online retteark og mundtlige prøve oplæg

mathematics kota damansara singapore math academy - Sep 10 2022

web singapore math singapore math academy mathematics mathematics centre enrichment centre tuition centre primary maths secondary maths igcse cambridge

[fsamatematik cyberlab sutd edu sg](#) - May 18 2023

web preparing test takers to ace the fsa math test this fsa math workbook s new edition has been updated to replicate questions appearing on the most recent fsa math tests here is intensive preparation for the fsa math test and a precious learning tool for test takers who need extra practice in math to raise their fsa math scores

[sasbadi sdn bhd home](#) - Oct 11 2022

web sasbadi sdn bhd home home download centre workbook modul aktiviti formula a kssm resos guru digital rgd formula a pt3 kssm matematik rgd formula a pt3 kssm matematik tingkatan 1

fsa matematik facit maj - May 06 2022

web fsa matematik facit maj particle accelerator physics oct 29 2021 particle accelerator physics covers the dynamics of relativistic particle beams basics of particle guidance and focusing lattice design characteristics of beam transport systems and circular accelerators

fp9 maj 2010 folkeskoleløsninger i matematik - Mar 04 2022

web 1 1 2 n 0 2 n n 1 2 2 n 1 2 2 9 3 2 n 1 2 n n 1 2 2 n 1 2 3 25 5 2 n 2 2 n n 1 2 2 n 1 2 4 49 7 2 n 3 2 n n 1 2 2 n 1 2
besvarelser til eksamenssæt for folkeskolen hf og gymnasiet i matematik fysik kemi og biologi

fsa matematik facit - Jun 07 2022

web in mind this fsa matematik facit but end occurring in harmful downloads rather than enjoying a fine book with a cup of coffee in the afternoon instead they juggled behind some harmful virus inside their computer fsa matematik facit is welcoming in our digital library an online entrance to it is set as

prøvebanken - Oct 23 2023

web prøvebanken giver derudover fra 2023 adgang til testopgaver i læsning og matematik der har været brugt i folkeskolens nationale overgangstest adgang til prøve eksamens og testopgaver er beskyttet med personligt uni login og omfattet af ophavsret og må ikke gøres tilgængelige i anden sammenhæng eller på internettet

financial services and markets act 2022 monetary authority of - Mar 16 2023

web apr 27 2023 the financial services and markets act 2022 fsma is an omnibus act for the sector wide regulation of financial services and markets parliament passed the fsma on 5 april 2022 the fsma will be implemented in phases with phase 1

fast b e s t fsa mathematics reference sheets packet - Apr 17 2023

web aug 1 2023 fsa mathematics reference sheets packet back forms signs practice materials

xmeye device database - Nov 07 2022

web mar 1 2019 user manual untitled xmeye android mobile monitoring client english manual 1 introduction brief is the video surveillance application developed for os this supports that higher than 2 3 released android users 2014 8 15 mkwinkel co za 2021 06 xmeye android mobile monitoring client english manual written by the test

xmeye apps on google play - Sep 05 2022

web sep 4 2023 about this app arrow forward xmeye is video monitoring software for ipc and dvr with cloud technology easy log in by the device s serial number to show the live view monitoring video to android phone and do operation accordingly

[xmeye android mobile monitoring client english manual](#) - Jun 14 2023

web xmeye is the video surveillance application developed for android os this application supports os that is higher than 2 3

released manual will mainly focus on how to set up and use xmeye software for android os 1 2 main functions main functions support chinese english view the video in real time via wifi and gprs

xmeye manual xmeye - Jul 15 2023

web search and download xmeye into your mobile device from app store google play or scan the qr codes below to download xmeye android monitoring client english manual inet org - Aug 16 2023

web introductions 1 1brief introductions android is the video surveillance application designed for our monitor devices this application supports android that is higher than 4 1 released the manual will mainly introduce how to set and use xmeye 1 2 main functions main functions support chinese english view the video on real time via wifi and gprs

xmeye android mobile monitoring client english manual - Jul 03 2022

web xmeye android mobile monitoring client english manual author git 02 infra openwrt org 2023 08 29 11 27 40 subject xmeye android mobile monitoring client english manual keywords xmeye android mobile monitoring client english manual created date 8 29 2023

xmeye android user s manual 2014 8 15 pdf scribd - Mar 11 2023

web aug 15 2014 xmeye android user s manual 2014 8 15 free download as pdf file pdf text file txt or read online for free user s manual

index xmeye net - Aug 04 2022

web 2 the instructional videos of using cloud service 3 announcement of system account integration

evolveo xmeye monitoring system owner s manual manualzz - Feb 10 2023

web mar 25 2014 xmeye android mobile monitoring client english manual written by the test department prepared date 2014 03 25 version v1 0 1 introduction 3 1 1

switching language evolveo xmeye manualzz - Jan 09 2023

web view online or download pdf 1 mb evolveo xmeye owner s manual xmeye pdf manual download and more evolveo online manuals switching language

xmeye android mobile monitoring client english man manualzz - Apr 12 2023

web nov 20 2014 xmeye android mobile monitoring client english manual written by the test department prepared date 2014 11 20 version v1 0 1 introduction 3 1 1

xmeye android user manual pdf mobile app wi fi scribd - May 13 2023

web xmeye android user manual free download as pdf file pdf text file txt or read online for free this app was designed to control and view images from remote devices through android device support android 4 1 or higher version the manual will mainly introduce how to set up and use xmeye mobile video surveillance software

xmeye android mobile monitoring client english manual copy - Mar 31 2022

web we have the funds for xmeye android mobile monitoring client english manual and numerous book collections from fictions to scientific research in any way accompanied by them is this xmeye android mobile monitoring client

xmeye ios app user manual download level1 com - Feb 27 2022

web xmeye is a video surveillance software of mobile client which is developed for our monitoring devices it supports ios 8 1 or higher version the user manual will mainly introduce how to set and use our xmeye app 1 2 main function of product main function support chinese english and korean support watch the real time video via

[xmeye android mobile monitoring client english manual pdf](#) - Jan 29 2022

web we manage to pay for xmeye android mobile monitoring client english manual pdf and numerous ebook collections from fictions to scientific research in any way in the midst of them is this xmeye android mobile monitoring client english manual pdf that can be your partner xmeye for pc xmeye xmeye for pc download and view only ie browser is

xmeye and xmeye pro - Dec 08 2022

web xmeye pro xmeye pro is video monitoring software for ipc and dvr with cloud technology easy log in by the device s serial number to show the live view monitoring video to android phone and do operation accordingly android ios computer

xmeye android mobile monitoring client english manual - Dec 28 2021

web xmeye android mobile monitoring client english manual written by the test department prepared date 2014 11 20 version v1 0 1 introduction author regina shelton

xmeye android mobile monitoring client english manual pdf - May 01 2022

web client which enables location awareness and further allows mobile users to augment the collected data with comments digital photos digital audio or even small movies of artifacts like trees and other plants

installation evolveo xmeye manualzz - Oct 06 2022

web xmeye android mobile monitoring client english man vmeyecloud android cellphone monitoring client english manual hiseeu dvr nvr ios mobile app xmeye user manual

xmeye iphone mobile monitoring client english manualzz - Jun 02 2022

web oct 10 2014 xmeye iphone mobile monitoring client english manual written by the test department prepared date 2014 10 10 version v1 0 1 introduction 3 1 1

[the essential guide to warfare wookieepedia fandom](#) - Aug 20 2023

web oct 2 2012 extensively researched and inventively written star wars the essential guide to warfare combines action filled narrative with encyclopedic knowledge that

the essential guide to warfare star wars apple books - Sep 09 2022

web this ingenious step by step guide written by an elite trainer of fortune 50 ceos and g8 world leaders unlocks the secrets of nonverbal communication using a proven system

the essential guide to warfare star wars google books - Jul 19 2023

web the essential guide to warfare star wars by jason fry paul r urquhart 9780345477620 penguinrandomhouse com books the definitive guide to

the essential guide to warfare star wars google books - May 17 2023

web do you want to learn more about the history and tactics of the wars that shaped the star wars galaxy the essential guide to warfare star wars is a comprehensive and

star wars the essential guide to warfare starwars com - Jun 06 2022

the essential guide to warfare star wars apple - Nov 11 2022

web jun 17 2014 star wars the essential guide to warfare is the definitive guide to the ultimate intergalactic battlefield packed with original full color artwork it includes facts

the essential guide to warfare star wars paperback - Dec 12 2022

web star wars essential guides is a series of star wars legends reference books that were published by del rey from 1995 to 2012 the series began with the essential guide to

star wars the essential guide to warfare goodreads - Jan 13 2023

web the definitive guide to the ultimate intergalactic battlefield like many a great epic star wars is rooted in a rich history of armed conflict now for the first time

star wars the essential guide to warfare archive org - Sep 21 2023

web jul 20 2021 star wars essential guide to warfare addeddate 2021 07 20 17 49 48 identifier star wars fry jason urquhart paul r the essential guide to warfare identifier ark ark 13960 t43s2v60j ocr tesseract 5 0 0 alpha 20201231 10 g1236

star wars the essential guide to warfare paperback - Oct 10 2022

web feb 11 2014 title books comics url starwars com news category books comics

star wars the essential guide to warfare author s cut part 9 - Jul 07 2022

web star wars the essential guide to warfare by fry jason 1969 publication date 2012 topics star wars films miscellanea publisher new york lucas books del rey

the essential guide to warfare star wars penguin random - Jun 18 2023

web apr 3 2012 extensively researched and inventively written star wars the essential guide to warfare combines action filled narrative with encyclopedic knowledge that

the essential guide to warfare overdrive - Feb 14 2023

web apr 3 2012 paperback like many a great epic star wars is rooted in a rich history of armed conflict now for the first time the facts figures and backstories of major clashes

star wars essential guides wookieepedia fandom - Aug 08 2022

web jan 9 2014 star wars the essential guide to warfare author s cut part 4 the rise of the republic january 9 2014 january 9 2014 jan 9 show more more from star

star wars the essential guide to warfare fry jason 1969 - Feb 02 2022

the essential guide to warfare star wars star wars essential - Apr 16 2023

web apr 3 2012 a new never before published entry in our extremely popular series of fully illustrated star wars essential guides the essential guide to warfare is the book

the essential guide to warfare star wars penguin random - Mar 15 2023

web like jedi vs sith and the essential atlas this book combines artwork wookieepedia style information and in universe fictional accounts to provide a picture of warfare in the

the essential guide to warfare star wars idioma in - May 05 2022

star wars the essential guide to warfare - Apr 04 2022

the essential guide to warfare starwars com - Mar 03 2022