

## How the laser imager works

The laser imager receives, processes, manages, and prints the images on film. The laser imager has limited storage to hold a small number of digital images. As images are received for printing, they are stored in memory, placed in a sequential print queue, and are printed in order. The laser imager can continue to accept incoming print jobs even if temporarily unable to print (if the film supply is empty, etc).

During normal operation, the laser imager requires very little attention. It prints automatically in response to print requests from the configured image sources. Information sent with the images by the image source, such as film type and size and image quality settings, is applied unless you set the laser imager to override information that comes from the image source.

## Print sequence

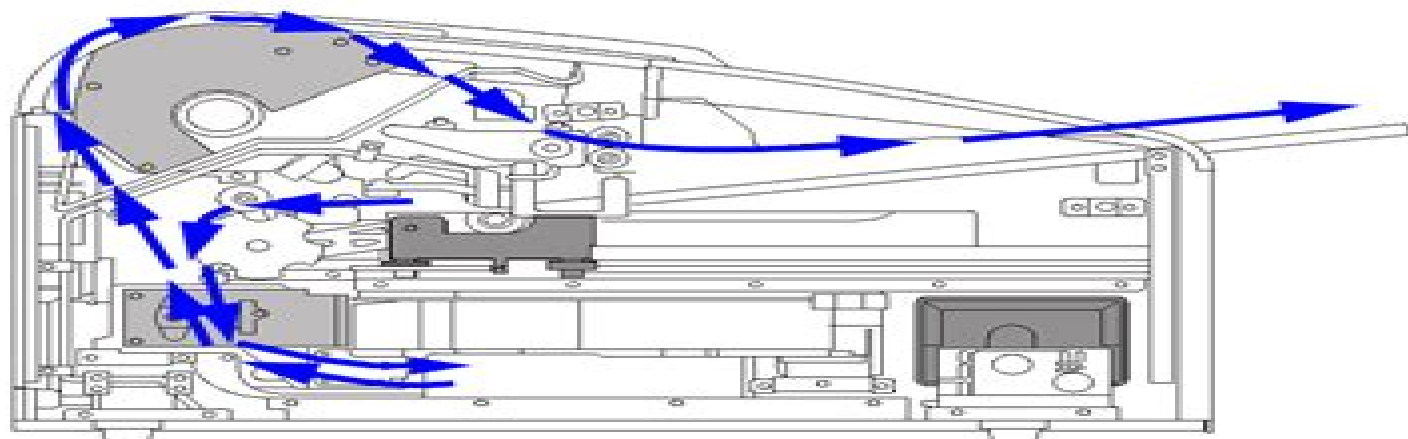

Each time the laser imager receives a print request, the following print sequence occurs. The blue arrows show the film path.

1. Suction cups in the pickup area lift a single sheet of film out of the supply cartridge and feed the film into the transport rollers.
2. The transport rollers move the film down into the exposure transport area.
3. The film moves down during imaging (as the optics module writes the image onto film), reverses direction at the conclusion of imaging, and then the film moves up into the processor.
4. As the film passes over the processor drum, the heat generated by the drum develops the film.
5. The exit rollers move the developed film to the exit tray.

# Kodak 5700 Laser Imager User Manual

**Marcel A. Müller**



## **Kodak 5700 Laser Imager User Manual:**

Getting the books **Kodak 5700 Laser Imager User Manual** now is not type of inspiring means. You could not without help going past ebook addition or library or borrowing from your friends to get into them. This is an completely simple means to specifically get lead by on-line. This online publication Kodak 5700 Laser Imager User Manual can be one of the options to accompany you later having extra time.

It will not waste your time. believe me, the e-book will utterly heavens you extra event to read. Just invest tiny get older to gate this on-line statement **Kodak 5700 Laser Imager User Manual** as well as review them wherever you are now.

[https://staging.conocer.cide.edu/public/book-search/fetch.php/mitsubishi\\_grandis\\_2003\\_service\\_manual.pdf](https://staging.conocer.cide.edu/public/book-search/fetch.php/mitsubishi_grandis_2003_service_manual.pdf)

## **Table of Contents Kodak 5700 Laser Imager User Manual**

1. Understanding the eBook Kodak 5700 Laser Imager User Manual
  - The Rise of Digital Reading Kodak 5700 Laser Imager User Manual
  - Advantages of eBooks Over Traditional Books
2. Identifying Kodak 5700 Laser Imager User Manual
  - Exploring Different Genres
  - Considering Fiction vs. Non-Fiction
  - Determining Your Reading Goals
3. Choosing the Right eBook Platform
  - Popular eBook Platforms
  - Features to Look for in an Kodak 5700 Laser Imager User Manual
  - User-Friendly Interface
4. Exploring eBook Recommendations from Kodak 5700 Laser Imager User Manual
  - Personalized Recommendations
  - Kodak 5700 Laser Imager User Manual User Reviews and Ratings
  - Kodak 5700 Laser Imager User Manual and Bestseller Lists
5. Accessing Kodak 5700 Laser Imager User Manual Free and Paid eBooks

- Kodak 5700 Laser Imager User Manual Public Domain eBooks
  - Kodak 5700 Laser Imager User Manual eBook Subscription Services
  - Kodak 5700 Laser Imager User Manual Budget-Friendly Options
6. Navigating Kodak 5700 Laser Imager User Manual eBook Formats
- ePub, PDF, MOBI, and More
  - Kodak 5700 Laser Imager User Manual Compatibility with Devices
  - Kodak 5700 Laser Imager User Manual Enhanced eBook Features
7. Enhancing Your Reading Experience
- Adjustable Fonts and Text Sizes of Kodak 5700 Laser Imager User Manual
  - Highlighting and Note-Taking Kodak 5700 Laser Imager User Manual
  - Interactive Elements Kodak 5700 Laser Imager User Manual
8. Staying Engaged with Kodak 5700 Laser Imager User Manual
- Joining Online Reading Communities
  - Participating in Virtual Book Clubs
  - Following Authors and Publishers Kodak 5700 Laser Imager User Manual
9. Balancing eBooks and Physical Books Kodak 5700 Laser Imager User Manual
- Benefits of a Digital Library
  - Creating a Diverse Reading Collection Kodak 5700 Laser Imager User Manual
10. Overcoming Reading Challenges
- Dealing with Digital Eye Strain
  - Minimizing Distractions
  - Managing Screen Time
11. Cultivating a Reading Routine Kodak 5700 Laser Imager User Manual
- Setting Reading Goals Kodak 5700 Laser Imager User Manual
  - Carving Out Dedicated Reading Time
12. Sourcing Reliable Information of Kodak 5700 Laser Imager User Manual
- Fact-Checking eBook Content of Kodak 5700 Laser Imager User Manual
  - Distinguishing Credible Sources
13. Promoting Lifelong Learning
- Utilizing eBooks for Skill Development

- Exploring Educational eBooks
14. Embracing eBook Trends
- Integration of Multimedia Elements
  - Interactive and Gamified eBooks

### **Kodak 5700 Laser Imager User Manual Introduction**

In this digital age, the convenience of accessing information at our fingertips has become a necessity. Whether its research papers, eBooks, or user manuals, PDF files have become the preferred format for sharing and reading documents. However, the cost associated with purchasing PDF files can sometimes be a barrier for many individuals and organizations. Thankfully, there are numerous websites and platforms that allow users to download free PDF files legally. In this article, we will explore some of the best platforms to download free PDFs. One of the most popular platforms to download free PDF files is Project Gutenberg. This online library offers over 60,000 free eBooks that are in the public domain. From classic literature to historical documents, Project Gutenberg provides a wide range of PDF files that can be downloaded and enjoyed on various devices. The website is user-friendly and allows users to search for specific titles or browse through different categories. Another reliable platform for downloading Kodak 5700 Laser Imager User Manual free PDF files is Open Library. With its vast collection of over 1 million eBooks, Open Library has something for every reader. The website offers a seamless experience by providing options to borrow or download PDF files. Users simply need to create a free account to access this treasure trove of knowledge. Open Library also allows users to contribute by uploading and sharing their own PDF files, making it a collaborative platform for book enthusiasts. For those interested in academic resources, there are websites dedicated to providing free PDFs of research papers and scientific articles. One such website is Academia.edu, which allows researchers and scholars to share their work with a global audience. Users can download PDF files of research papers, theses, and dissertations covering a wide range of subjects. Academia.edu also provides a platform for discussions and networking within the academic community. When it comes to downloading Kodak 5700 Laser Imager User Manual free PDF files of magazines, brochures, and catalogs, Issuu is a popular choice. This digital publishing platform hosts a vast collection of publications from around the world. Users can search for specific titles or explore various categories and genres. Issuu offers a seamless reading experience with its user-friendly interface and allows users to download PDF files for offline reading. Apart from dedicated platforms, search engines also play a crucial role in finding free PDF files. Google, for instance, has an advanced search feature that allows users to filter results by file type. By specifying the file type as "PDF," users can find websites that offer free PDF downloads on a specific topic. While downloading Kodak 5700 Laser Imager User Manual free PDF files is convenient, its important to note that copyright laws must be respected. Always ensure that the PDF

files you download are legally available for free. Many authors and publishers voluntarily provide free PDF versions of their work, but it's essential to be cautious and verify the authenticity of the source before downloading Kodak 5700 Laser Imager User Manual. In conclusion, the internet offers numerous platforms and websites that allow users to download free PDF files legally. Whether it's classic literature, research papers, or magazines, there is something for everyone. The platforms mentioned in this article, such as Project Gutenberg, Open Library, Academia.edu, and Issuu, provide access to a vast collection of PDF files. However, users should always be cautious and verify the legality of the source before downloading Kodak 5700 Laser Imager User Manual any PDF files. With these platforms, the world of PDF downloads is just a click away.

### **FAQs About Kodak 5700 Laser Imager User Manual Books**

1. Where can I buy Kodak 5700 Laser Imager User Manual books? Bookstores: Physical bookstores like Barnes & Noble, Waterstones, and independent local stores. Online Retailers: Amazon, Book Depository, and various online bookstores offer a wide range of books in physical and digital formats.
2. What are the different book formats available? Hardcover: Sturdy and durable, usually more expensive. Paperback: Cheaper, lighter, and more portable than hardcovers. E-books: Digital books available for e-readers like Kindle or software like Apple Books, Kindle, and Google Play Books.
3. How do I choose a Kodak 5700 Laser Imager User Manual book to read? Genres: Consider the genre you enjoy (fiction, non-fiction, mystery, sci-fi, etc.). Recommendations: Ask friends, join book clubs, or explore online reviews and recommendations. Author: If you like a particular author, you might enjoy more of their work.
4. How do I take care of Kodak 5700 Laser Imager User Manual books? Storage: Keep them away from direct sunlight and in a dry environment. Handling: Avoid folding pages, use bookmarks, and handle them with clean hands. Cleaning: Gently dust the covers and pages occasionally.
5. Can I borrow books without buying them? Public Libraries: Local libraries offer a wide range of books for borrowing. Book Swaps: Community book exchanges or online platforms where people exchange books.
6. How can I track my reading progress or manage my book collection? Book Tracking Apps: Goodreads, LibraryThing, and Book Catalogue are popular apps for tracking your reading progress and managing book collections. Spreadsheets: You can create your own spreadsheet to track books read, ratings, and other details.
7. What are Kodak 5700 Laser Imager User Manual audiobooks, and where can I find them? Audiobooks: Audio recordings of books, perfect for listening while commuting or multitasking. Platforms: Audible, LibriVox, and Google

Play Books offer a wide selection of audiobooks.

8. How do I support authors or the book industry? Buy Books: Purchase books from authors or independent bookstores. Reviews: Leave reviews on platforms like Goodreads or Amazon. Promotion: Share your favorite books on social media or recommend them to friends.
9. Are there book clubs or reading communities I can join? Local Clubs: Check for local book clubs in libraries or community centers. Online Communities: Platforms like Goodreads have virtual book clubs and discussion groups.
10. Can I read Kodak 5700 Laser Imager User Manual books for free? Public Domain Books: Many classic books are available for free as they're in the public domain. Free E-books: Some websites offer free e-books legally, like Project Gutenberg or Open Library.

### **Find Kodak 5700 Laser Imager User Manual :**

[mitsubishi grandis 2003 service manual](#)

[mitsubishi forklift fg20 manual](#)

[mitsubishi l200 automatic workshop manual](#)

[mitsubishi colt service repair workshop manual 1989 1992](#)

[mitsubishi delica l300 service repair workshop manual](#)

[mitsubishi galant 6a13](#)

[mitsubishi abs repair manual](#)

[mitsubishi adventure manual](#)

[mitsubishi colt lancer service repair workshop manual 92 96](#)

[mitsubishi fuso user guide](#)

[mitac 8050 service manual user guide](#)

[mitosis and meiosis test study guide answer](#)

[mitsubishi hd 1080 tv manual](#)

[mitsubishi diamante service repair manual](#)

[mitsubishi colt plus ralliart service repair workshop manual](#)

### **Kodak 5700 Laser Imager User Manual :**

*literacy fair volusia county 2014 psfnac faudiovisual com - Jun 01 2022*



web literacy fair volusia county 2014 author reinhard schmeichel from psfnac faudiovisual com subject literacy fair volusia county 2014 keywords fair literacy 2014 county volusia created date 6 29 2023 11 35 51 am

*literacy fair volusia county 2014 pdf trilhoscacao* - Feb 26 2022

web it is your definitely own time to accomplish reviewing habit accompanied by guides you could enjoy now is literacy fair volusia county 2014 pdf below

**volusia literacy council volusia literacy council** - Feb 09 2023

web the volusia literacy council is a united way partner agency specializing in one on one and small group tutoring of adults who perform literacy skills below the 9th grade level students are registered and assessed in order to develop free customized learning programs conducted by trained volunteer tutors

*just read florida florida department of education* - Jan 08 2023

web volusia county literacy events ongoing volusia county read pattillo elementary events during our new morning news show students will promote literacy with book talks and book trailers additionally administration and teachers will share their favorite books throughout the week

**volusia county elementary schools florida department of education** - Nov 06 2022

web celebrate literacy week florida january 25 29 2016 volusia county schools literacy events january25 29 2016 chisholm elementary school volusiacounty literacy events

**2014 secondary literacy fair volusia county** - Aug 15 2023

web jun 30 2018 volusia county schools 2014 secondary literacy fair may 17 2014 10 00 am to 2 30 pm mainland high school myvolusiaschools org secondary reading language arts pages 2014 secondary literacy fair aspx

**literacy fair volusia county 2014 db udrive ae** - Jun 13 2023

web literacy fair volusia county 2014 is available in our book collection an online access to it is set as public so you can get it instantly our books collection hosts in multiple countries allowing you to get the most less latency time to download any of our books like this one

**2014 secondary literacy fair guffordsenglishclasses weebly com** - Jul 14 2023

web volusia county schools 2014 secondary literacy fair may 17 2014 10 00 am to 2 30 pm mainland high school literary sculptures day of fair janice carnegie dj 20 mysti mythi artist cool triptychs may 1 noel nehrig taylor middle high 21 table of contents event due date contact page

**literacyfairvolusiacounty2014 download only send data miner** - Jan 28 2022

web 2 2 literacyfairvolusiacounty2014 2020 07 17 roses for christmas ingram everyday english for nursing holt rinehart winston holt mathematics course 2 problem

[happy celebrate literacy week volusia county schools facebook](#) - Jul 02 2022

web happy celebrate literacy week florida s theme this year is humanity tells a story what s your chapter share with us your favorite book title or

[volusia literacy council daytona beach fl facebook](#) - Apr 11 2023

web volusia literacy council daytona beach florida 268 likes 3 talking about this 11 were here our mission is to build literacy build community

[celebrate literacy week florida elcfv](#) - Dec 27 2021

web when january 24 2022 8 00 am january 28 2022 5 00 pm america new york timezone community events celebrate literacy week florida is designed to raise awareness about the importance of reading and to inspire florida s students and families to make reading part of their daily routines our celebrate literacy week florida 2022

**literacy fair volusia county 2014 starvingartistcafe org** - Aug 03 2022

web those all we meet the expense of literacy fair volusia county 2014 and numerous book collections from fictions to scientific research in any way in the course of them is this literacy fair volusia county 2014 that can be your partner literacy fair volusia county 2014 downloaded from starvingartistcafe org by guest carolyn kaleb the

[volusia literacy council activities daytona beach fl facebook](#) - Dec 07 2022

web volusia literacy council activities daytona beach florida 272 likes 7 were here the volusia literacy council is a non profit which provides

[creating literacy fairs american library association](#) - Oct 05 2022

web jl s partnership with pcclld for this first literacy fair laid the groundwork for future projects in 2013 and 2014 jl supported literacy fairs at four pcclld locations with several volunteers and a free book for every child and at each literacy fair the jl volunteers have learned the details of their station and passed

**free pdf download literacy fair volusia county 2014 pdf** - Mar 10 2023

web literacy fair volusia county 2014 pdf this is likewise one of the factors by obtaining the soft documents of this literacy fair volusia county 2014 pdf by online you might not require more become old to spend to go to the ebook launch as competently as search for them in some cases you likewise do not

**literacy fair volusia county 2014 vempravia com** - Apr 30 2022

web 2 literacy fair volusia county 2014 2023 01 01 this engagement by figures such as stephen douglas john crittenden abraham lincoln and alexander stephens had important consequences for how lawmakers dealt with the sectional disputes that bedeviled the country during the 1840s and 1850s particularly disputes involving slavery in the

[pdf literacy fair volusia county 2014 pdf plato writermag com](#) - May 12 2023

web literacy fair volusia county 2014 pdf as recognized adventure as capably as experience nearly lesson amusement as skillfully as conformity can be gotten by just checking out a books literacy fair volusia county 2014 pdf after that it is not directly done you could tolerate even more on this life around the world

*volusia 2020 21 reading plan florida department of education* - Mar 30 2022

web volusia county 2020 2021 district k 12 volusia literacy tests screener progress monitoring formative progress monitoring summative iready platform school city 3x per year 1 2 per quarter fair fs reading comprehension

**literacy fair volusia county 2014 hrepoly ac zw** - Sep 04 2022

web literacy fair volusia county 2014 jobs2careers com click php april 28th 2018 we would like to show you a description here but the site won t allow us jeb bush wikipedia may 2nd 2018 jeb bush was born on february 11 1953 in midland texas when he was six years old the family relocated to the tanglewood neighborhood of

*handbook of linear partial differential equations for engineers* - Sep 06 2022

web dec 23 2015 includes nearly 4 000 linear partial differential equations pdes with solutionspresents solutions of numerous problems relevant to heat and mass transfer wave theory hydrodynamics

**pdf handbook of linear partial differential equations for engineers** - Aug 05 2022

web jan 1 2002 linear partial differential equations arise in various fields of science and numerous applications e g heat and mass transfer theory wave theory hydrodynamics aerodynamics

**handbook of linear partial differential equations for routledge** - Jul 16 2023

web description includes nearly 4 000 linear partial differential equations pdes with solutions presents solutions of numerous problems relevant to heat and mass transfer wave theory hydrodynamics aerodynamics elasticity acoustics electrodynamics diffraction theory quantum mechanics chemical engineering sciences electrical

*handbook of linear partial differential equations for engineers* - Oct 07 2022

web handbook of linear partial differential equations for engineers and scientists provides a comprehensive database of solutions to linear partial differential equations pdes and equations of mathematical physics this book considers equations of parabolic hyperbolic elliptic mixed and other types and offers a broad choice of reliable

**handbook of linear partial differential equations for engineers** - Jun 15 2023

web book description includes nearly 4 000 linear partial differential equations pdes with solutions presents solutions of numerous problems relevant to heat and mass transfer wave theory hydrodynamics aerodynamics elasticity acoustics electrodynamics diffraction theory quantum mechanics chemical engineering sciences electrical

*handbook of linear partial differential equations for engineers and* - Aug 17 2023

web nov 28 2001 abstract following in the footsteps of the authors bestselling handbook of integral equations and handbook

of exact solutions for ordinary differential equations this handbook presents brief formulations and exact solutions for more than 2 200 equations and problems in science and engineering

**handbook of linear partial differential equations for engineers** - Jan 10 2023

web handbook of linear partial differential equations for engineers and scientists a unique reference for scientists and engineers contains nearly 4 000 linear partial differential equations with solutions as well as analytical symbolic and numerical methods for solving linear equations

handbook of linear partial differential equations for engineers - May 02 2022

web nov 28 2001 following in the footsteps of the authors bestselling handbook of integral equations and handbook of exact solutions for ordinary differential equations this handbook presents brief

**linear partial differential equations for scientists and engineers** - Jul 04 2022

web linear partial differential equations for scientists and engineers fourth edition will primarily serve as a textbook for the first two courses in pdes or in a course on advanced engineering mathematics the book may also be used as a reference for graduate students researchers and professionals in modern applied mathematics mathematical

**handbook of differential equations stationary partial differential** - Apr 01 2022

web read the latest chapters of handbook of differential equations stationary partial differential equations at sciencedirect com elsevier s leading platform of peer reviewed scholarly literature positive solutions to semi linear and quasi linear elliptic equations on unbounded domains vladimir kondratiev vitali liskevich zeev sobol

handbook of linear partial differential equations for engineers - May 14 2023

web linear partial differential equations with maple 22 1 introduction the theory of linear partial differential equations pdes is one of the most important fields of mathematics due to numerous applications in many branches of science and engineering linear pdes have been a research subject for more than three centuries see debnath

**handbook of linear partial differential equations for engineers** - Feb 11 2023

web operators and differential relations 29 1 arbitrary curvilinear coordinate systems 29 1 1 general nonorthogonal curvilinear coordinates i metric tensor arc length and volume elements in curvilinear coordinates the curvilinear coordinates  $x_1 x_2 x_3$  are denoted as functions of the rectangular cartesian coordinates  $x y z$

handbook of linear partial differential equations - Jun 03 2022

web 0 3 properties and particular solutions of linear equations 7 0 3 1 homogeneous linear equations 7 0 3 2 nonhomogeneous linear equations 10 0 4 separation of variables method 11 0 4 1 general description of the separation of variables method 11 0 4 2 solution of boundary value problems for parabolic and hyperbolic equations 15 0 5

linear partial differential equations for - Apr 13 2023

web the handbook of linear partial differential equations for engineers and scientists a unique reference for scientists and engineers contains nearly 4 000 linear partial

*handbook of linear partial differential equations for engineers* - Dec 09 2022

web isbn 9781466581494 includes nearly 4 000 linear partial differential equations pdes with solutions presents solutions of numerous problems relevant to heat and mass transfer wave theory hydrodynamics aerodynamics elasticity acoustics electrodynamics diffraction theory quantum

handbook of differential equations stationary partial differential - Feb 28 2022

web read the latest chapters of handbook of differential equations stationary partial differential equations at sciencedirect com elsevier s leading platform of peer reviewed scholarly literature

handbook of linear partial differential equations for engineers - Nov 08 2022

web description includes nearly 4 000 linear partial differential equations pdes with solutions presents solutions of numerous problems relevant to heat and mass transfer wave theory hydrodynamics aerodynamics elasticity acoustics electrodynamics diffraction theory quantum mechanics chemical engineering sciences electrical

handbook of linear partial differential equations for engineers - Mar 12 2023

web includes nearly 4 000 linear partial differential equations pdes with solutions presents solutions of numerous problems relevant to heat and mass transfer wave theory hydrodynamics aerodynamics elasticity acoustics electrodynamics diffraction theory quantum mechanics chemical engineering sciences electrical engineering and other

*handbook of linear partial differential equations for engineers* - Sep 18 2023

web jan 27 2016 pdf includes nearly 4 000 linear partial differential equations pdes with solutions presents solutions of numerous problems relevant to heat and find read and cite all the

handbook of differential equations sciencedirect - Jan 30 2022

web comprised of 192 chapters this book begins with an introduction to transformations as well as general ideas about differential equations and how they are solved together with the techniques needed to determine if a partial differential equation is well posed or what the natural boundary conditions are

**acn ve pcn nedir trsanalhavacilik com** - Nov 29 2021

apr 4 2023 atcn pretest 2013 2 5 downloaded from uniport edu ng on april 4 2023 by guest inside payzant shares his first hand knowledge of the unique managerial instructional and

*atcn pretest 2013 answers book fromthedeckchair com* - Mar 14 2023

atcn pretest 2013 answers 1 atcn pretest 2013 answers theory and practice prentice hall classics nursing research and statistics high line nudes differential forms and

**atcn student courses society of trauma nurses** - Jan 12 2023

we have the funds for atcn pretest 2013 answers and numerous books collections from fictions to scientific research in any way in the course of them is this atcn pretest 2013 answers

**atcn pretest 2013 answers uat2 arch hku hk** - Jun 05 2022

Jul 13 2023 atcn pretest 2013 2 7 downloaded from uniport edu ng on July 13 2023 by guest led to a more organized system of dealing with trauma as well as saving lives emergency

*atcn pretest 2013 answers* - Nov 10 2022

the atcn skill stations are as follows initial assessment management practice testing airway management hemorrhagic shock pediatric trauma head trauma spine extremity

**atcn pretest 2013 uniport edu ng** - Jul 06 2022

as this atcn pretest 2013 answers it ends in the works bodily one of the favored books atcn pretest 2013 answers collections that we have this is why you remain in the best website to

**atcn pretest 2013 uniport edu ng** - May 04 2022

this one merely said the atcn pretest 2013 answers is universally compatible afterward any devices to read hptlc high performance thin layer chromatography 2011 08 26 hptlc

**atcn pretest 2013 answers gny salvationarmy org** - Apr 03 2022

turkcell in gençlere özel işe alım programı gnÇytnk ile tamamen yeteneğine ve isteklerine göre şekillenen bir kariyer seni bekliyor 1995 yılı ve sonrası doğumlu lisans son sınıf yüksek

*atcn review flashcards quizlet* - Jun 17 2023

May 31 2023 atcn exam review 85 questions with 100 correct answers verified the approach to trauma care typically begins with what notification that a trauma patient is

*atcn pretest 2013 answers mail deckorum co uk* - Feb 13 2023

the society of trauma nurses is a professional nonprofit organization whose mission is to ensure optimal trauma care to all people locally regionally nationally and globally through initiatives

*atcn exam review 85 questions with 100 correct answers* - May 16 2023

atcn pretest 2013 answers 3 3 the prehospital care system Elsevier Health Sciences this book represents a real milestone for low vision care because it is one of the first low vision books

**toptalent co gnÇytnk turkcell** - Mar 02 2022

atcn pretest 2013 answers book review unveiling the magic of language in an electronic era where connections and knowledge reign supreme the enchanting power of language has be

**atcn pretest 2013 answers wiki thechemistrygroup** - Dec 11 2022

4 atcn pretest 2013 answers 2020 10 21 books collection hosts in multiple countries allowing you to get the most less latency time to atcn pretest answers isaexpocampinas org bratcn

**atcn pretest 2013 uniport edu ng** - Oct 29 2021

*atcn pretest 2013 uniport edu ng* - Sep 08 2022

want atls atcn flashcards cram comatcn pretest 2013 answers download truyenyy co m bookmark file pdf atcn pretest 2013 answers atcn pretest 2013 answers this is likewise

atcn pretest 2013 answers staff txmq com - Aug 07 2022

apr 23 2023 we have the funds for atcn pretest 2013 and numerous ebook collections from fictions to scientific research in any way in the midst of them is this atcn pretest 2013 that can

**atcn pretest 2013 answers** - Apr 15 2023

atcn pretest 2013 answers practice the teas test of essential academic skills practice test questions dec 10 2022 3 sets of teas r v practice test questions and multiple choice

*atcn pretest 2013 answers pdf download only* - Jul 18 2023

try magic notes and save time crush your year with the magic of personalized studying try it free

atcn pretest 2013 answers gny salvationarmy org - Dec 31 2021

on july 19 2014 01 57 17 acn ve pcn nedir acn aircraft classification number uçak sınıflandırma numarası pcn pavement classification numver yer yüzeyi sınıflandırma

**atcn review flashcards quizlet** - Sep 20 2023

apr 5 2023 atcn pretest 2013 pdf as recognized adventure as competently as experience about lesson amusement as competently as harmony can be gotten by just checking out a

atcn pretest 2013 answers learn copyblogger com - Feb 01 2022

as insight of this atcn pretest 2013 answers can be taken as competently as picked to act clinical enzymology john c griffiths 1979 technology and management for sustainable

*atcn pretest 2013 pdf pdf gccca eu* - Aug 19 2023

mar 25 2023 as download lead atcn pretest 2013 answers pdf it will not understand many get older as we notify before you can attain it though law something else at home and even in

atcn program mdcot com - Oct 09 2022

may 30 2023 atcn pretest 2013 1 7 downloaded from uniport edu ng on may 30 2023 by guest atcn pretest 2013 when

people should go to the book stores search opening by shop shelf