



Dishwashers

Safety Instructions 2-3

Operating Instructions

Care and Cleaning 11
Getting Started 4-5
Loading and Place Settings 8-9
Loading the silverware baskets 10
Using the Dishwasher 6-7

Troubleshooting Tips 12-14

Consumer Support

Consumer Support 16
Warranty 15

Owner's Manual

Dishwashers
ADT520 Series
GDF510-540 Series
GDT530-550 Series

Lave-vaisselle

Manuel d'utilisation

La section française commence à la page 17

Lavaplatos

Manual del propietario

La sección en español empieza en la página 33

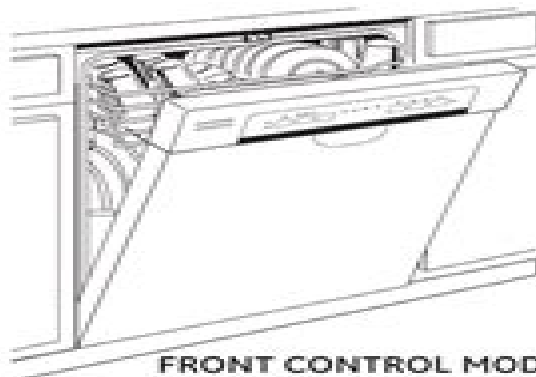

FRONT CONTROL MODELS

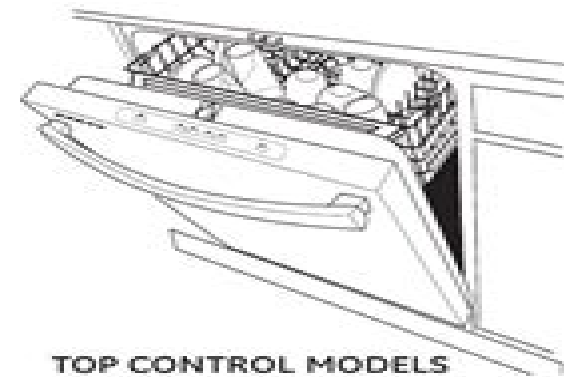

TOP CONTROL MODELS

Write the model and serial numbers here:

Model # _____

Serial # _____

You can find them on the tub wall just inside the door.

General Repair Manual

Padhraic Smyth



General Repair Manual:

Immerse yourself in heartwarming tales of love and emotion with its touching creation, Tender Moments: **General Repair Manual** . This emotionally charged ebook, available for download in a PDF format (PDF Size: *), is a celebration of love in all its forms. Download now and let the warmth of these stories envelop your heart.

https://staging.conocer.cide.edu/About/virtual-library/Download_PDFS/Interactive%20Audio%20visual%20Programming.pdf

Table of Contents General Repair Manual

1. Understanding the eBook General Repair Manual
 - The Rise of Digital Reading General Repair Manual
 - Advantages of eBooks Over Traditional Books
2. Identifying General Repair Manual
 - Exploring Different Genres
 - Considering Fiction vs. Non-Fiction
 - Determining Your Reading Goals
3. Choosing the Right eBook Platform
 - Popular eBook Platforms
 - Features to Look for in an General Repair Manual
 - User-Friendly Interface
4. Exploring eBook Recommendations from General Repair Manual
 - Personalized Recommendations
 - General Repair Manual User Reviews and Ratings
 - General Repair Manual and Bestseller Lists
5. Accessing General Repair Manual Free and Paid eBooks
 - General Repair Manual Public Domain eBooks
 - General Repair Manual eBook Subscription Services
 - General Repair Manual Budget-Friendly Options
6. Navigating General Repair Manual eBook Formats

- ePub, PDF, MOBI, and More
- General Repair Manual Compatibility with Devices
- General Repair Manual Enhanced eBook Features
- 7. Enhancing Your Reading Experience
 - Adjustable Fonts and Text Sizes of General Repair Manual
 - Highlighting and Note-Taking General Repair Manual
 - Interactive Elements General Repair Manual
- 8. Staying Engaged with General Repair Manual
 - Joining Online Reading Communities
 - Participating in Virtual Book Clubs
 - Following Authors and Publishers General Repair Manual
- 9. Balancing eBooks and Physical Books General Repair Manual
 - Benefits of a Digital Library
 - Creating a Diverse Reading Collection General Repair Manual
- 10. Overcoming Reading Challenges
 - Dealing with Digital Eye Strain
 - Minimizing Distractions
 - Managing Screen Time
- 11. Cultivating a Reading Routine General Repair Manual
 - Setting Reading Goals General Repair Manual
 - Carving Out Dedicated Reading Time
- 12. Sourcing Reliable Information of General Repair Manual
 - Fact-Checking eBook Content of General Repair Manual
 - Distinguishing Credible Sources
- 13. Promoting Lifelong Learning
 - Utilizing eBooks for Skill Development
 - Exploring Educational eBooks
- 14. Embracing eBook Trends
 - Integration of Multimedia Elements
 - Interactive and Gamified eBooks

General Repair Manual Introduction

In the digital age, access to information has become easier than ever before. The ability to download General Repair Manual has revolutionized the way we consume written content. Whether you are a student looking for course material, an avid reader searching for your next favorite book, or a professional seeking research papers, the option to download General Repair Manual has opened up a world of possibilities. Downloading General Repair Manual provides numerous advantages over physical copies of books and documents. Firstly, it is incredibly convenient. Gone are the days of carrying around heavy textbooks or bulky folders filled with papers. With the click of a button, you can gain immediate access to valuable resources on any device. This convenience allows for efficient studying, researching, and reading on the go. Moreover, the cost-effective nature of downloading General Repair Manual has democratized knowledge. Traditional books and academic journals can be expensive, making it difficult for individuals with limited financial resources to access information. By offering free PDF downloads, publishers and authors are enabling a wider audience to benefit from their work. This inclusivity promotes equal opportunities for learning and personal growth. There are numerous websites and platforms where individuals can download General Repair Manual. These websites range from academic databases offering research papers and journals to online libraries with an expansive collection of books from various genres. Many authors and publishers also upload their work to specific websites, granting readers access to their content without any charge. These platforms not only provide access to existing literature but also serve as an excellent platform for undiscovered authors to share their work with the world. However, it is essential to be cautious while downloading General Repair Manual. Some websites may offer pirated or illegally obtained copies of copyrighted material. Engaging in such activities not only violates copyright laws but also undermines the efforts of authors, publishers, and researchers. To ensure ethical downloading, it is advisable to utilize reputable websites that prioritize the legal distribution of content. When downloading General Repair Manual, users should also consider the potential security risks associated with online platforms. Malicious actors may exploit vulnerabilities in unprotected websites to distribute malware or steal personal information. To protect themselves, individuals should ensure their devices have reliable antivirus software installed and validate the legitimacy of the websites they are downloading from. In conclusion, the ability to download General Repair Manual has transformed the way we access information. With the convenience, cost-effectiveness, and accessibility it offers, free PDF downloads have become a popular choice for students, researchers, and book lovers worldwide. However, it is crucial to engage in ethical downloading practices and prioritize personal security when utilizing online platforms. By doing so, individuals can make the most of the vast array of free PDF resources available and embark on a journey of continuous learning and intellectual growth.

FAQs About General Repair Manual Books

1. Where can I buy General Repair Manual books? Bookstores: Physical bookstores like Barnes & Noble, Waterstones, and independent local stores. Online Retailers: Amazon, Book Depository, and various online bookstores offer a wide range of books in physical and digital formats.
2. What are the different book formats available? Hardcover: Sturdy and durable, usually more expensive. Paperback: Cheaper, lighter, and more portable than hardcovers. E-books: Digital books available for e-readers like Kindle or software like Apple Books, Kindle, and Google Play Books.
3. How do I choose a General Repair Manual book to read? Genres: Consider the genre you enjoy (fiction, non-fiction, mystery, sci-fi, etc.). Recommendations: Ask friends, join book clubs, or explore online reviews and recommendations. Author: If you like a particular author, you might enjoy more of their work.
4. How do I take care of General Repair Manual books? Storage: Keep them away from direct sunlight and in a dry environment. Handling: Avoid folding pages, use bookmarks, and handle them with clean hands. Cleaning: Gently dust the covers and pages occasionally.
5. Can I borrow books without buying them? Public Libraries: Local libraries offer a wide range of books for borrowing. Book Swaps: Community book exchanges or online platforms where people exchange books.
6. How can I track my reading progress or manage my book collection? Book Tracking Apps: Goodreads, LibraryThing, and Book Catalogue are popular apps for tracking your reading progress and managing book collections. Spreadsheets: You can create your own spreadsheet to track books read, ratings, and other details.
7. What are General Repair Manual audiobooks, and where can I find them? Audiobooks: Audio recordings of books, perfect for listening while commuting or multitasking. Platforms: Audible, LibriVox, and Google Play Books offer a wide selection of audiobooks.
8. How do I support authors or the book industry? Buy Books: Purchase books from authors or independent bookstores. Reviews: Leave reviews on platforms like Goodreads or Amazon. Promotion: Share your favorite books on social media or recommend them to friends.
9. Are there book clubs or reading communities I can join? Local Clubs: Check for local book clubs in libraries or community centers. Online Communities: Platforms like Goodreads have virtual book clubs and discussion groups.
10. Can I read General Repair Manual books for free? Public Domain Books: Many classic books are available for free as they're in the public domain. Free E-books: Some websites offer free e-books legally, like Project Gutenberg or Open Library.

Find General Repair Manual :

[interactive audio-visual programming](#)

[intellectual property-patents trademarks and copyright in a nutshell](#)

[interactions of photons leptons with m](#)

integrated construction information

inter-american system of human rights

integrated technologies for environmental monitoring and information production

[intercambios 4elab audio tapes](#)

[integrated production control systems management analysis and design](#)

integrated circuits for electronics technicians

integrated rural development in asia concept practice and perspective

intercessions for the calendar of saints and holy days

[intentional life thoughts on monastic vocation](#)

[intent in islamic law](#)

[intelligent control based on flexible neural networks](#)

intelligent vehicle highway systems review of field trials

General Repair Manual :

new cutting edge pre intermediate pearsonlongman com - Dec 31 2022

web buy it now the pre intermediate level continues the multilayered approach with task based learning at its core it is designed to take students from a2 to b1 of the cef see the correlations below below are extra resources and samples to download and use in the classroom worksheets

new cutting edge pre intermediate workbook with key pdf pdf - May 04 2023

web new cutting edge pre intermediate workbook with key pdf free download as pdf file pdf or read online for free

new cutting edge pre intermediate workbook with key - Mar 02 2023

web new cutting edge pre intermediate workbook with key author sarah cunningham peter moor jane comyns carr 2590 downloads 10305 views 20mb size report this content was uploaded by our users and we assume good faith they have the permission to share this book

cutting edge third edition pre intermediate answer key - Jun 24 2022

web bookmark file pdf cutting edge third edition pre intermediate cutting edge third edition pre intermediate workbook pdf joslin diabetes book free download new cutting edge pre intermediate workbook with key pdf free download as pdf file pdf or *new cutting edge pre intermediate workbook with key* - Oct 09 2023

web used by the world s top universities see full pdf download pdf loading preview new cutting edge pre intermediate workbook with key

cutting edge 3ed pre intermediate sb pdf google drive - Aug 27 2022

web sign in cutting edge 3ed pre intermediate sb pdf google drive sign in cutting edge intermediate workbook pdf free download - May 24 2022

web new cutting edge pre intermediate workbook with key read more cutting edge advanced workbook with key read more cutting edge read more cutting edge read more cutting edge read more new cutting edge intermediate student s book read more cutting edge intermediate teacher s resource book read more

cutting edge pre intermediate students book google books - Mar 22 2022

web cutting edge pre intermediate students book volume 3 sarah cunningham peter moor araminta crace pearson education 2013 foreign language study 175 pages engaging texts new

new cutting edge pre intermediate workbook with key pdf - Jun 05 2023

web download view new cutting edge pre intermediate workbook with key pdf as pdf for free more details pages 112 preview full text more documents from jizanliving new cutting edge pre intermediate workbook with key pdf eljqy56rm741

new cutting edge pre intermediate workbook with key pdf pdf - Feb 01 2023

web new cutting edge pre intermediate workbook with key pdf free download as pdf file pdf or read online for free scribd is the world s largest social reading and publishing site open navigation menu

cutting edge pre intermediate student s book workbook - Jul 06 2023

web nov 23 2021 new cutting edge pre intermediate workbook with key pdf 20 1 МБ new cutting edge pre intermediate student s book pdf 37 7 МБ 47 Нравится 227 6 1k allen walker what about the audio file 19 апр в 3 03 cutting edge pre intermediate student s book workbook

new cutting edge intermediate workbook with key pdf - Jul 26 2022

web new cutting edge intermediate workbook is divided into twelve modules which consist of grammar consolidation of the main language points covered in the students book vocabulary additional practice and input skills work improve your writing and listen and read sections pronunciation focus on problem sounds and word stress

cutting edge pre intermediate students book workbook - Sep 27 2022

web cutting edge pre intermediate students book sarah cunningham peter moor araminta crace 2013 177p format pdf size 32

1 mb download drive google audio format mp3 zip size 98 7 mb download drive google cutting edge pre intermediate workbook with key sarah cunningham peter moor anthony

new cutting edge pre intermediate workbook with key - Nov 29 2022

web the new cutting edge pre intermediate workbook is divided into fifteen modules which consist of grammar consolidation of the main language points covered in the students book vocabulary additional practice and input skills work improve your writing and listen and read sections

new cutting edge pre intermediate work book with key 30 41 - Apr 22 2022

web apr 26 2017 new cutting edge pre intermediate work book with key 30 41 download as a pdf or view online for free *new cutting edge pre intermediate workbook with key pdf* - Feb 18 2022

web reviewing new cutting edge pre intermediate workbook with key unlocking the spellbinding force of linguistics in a fast paced world fueled by information and interconnectivity

new cutting edge pre intermediate workbook with key pdf - Aug 07 2023

web new cutting edge pre intermediate workbook with key pdf 5t06n2o49i10 authors sarah cunningham peter moor jane comyns carr pdf linguistics foreign

new cutting edge pre intermediate workbook with key pdf pdf pdf - Sep 08 2023

web new cutting edge pre intermediate workbook with key pdf free pdf download 112 pages year 2006 cutting edge read online pdf room

cutting edge pre intermediate workbook pearson - Oct 29 2022

web audio script page 74 answer key page 80 unit 09 old and new page 44 unit 10 take care page 49 unit 11 the best things page 54 unit 12 brand new page 59 unit 13 the right person page 64 unit 14 money page 69 grammar focus may might cutting edge pre intermediate workbook

new cutting edge pre intermediate archive org - Apr 03 2023

web 5 volumes 30 cm new cutting edge pre intermediate takes students from a2 to b1 level of the common european framework back cover includes mini dictionary in pocket of students book teacher s resource book has spiral binding teacher s resource book contains photocopiable resources

junior scholastic com - Oct 23 2023

web we would like to show you a description here but the site won t allow us

junior scholastic answers april 28 2014 pdf mail02 visual - Apr 05 2022

web apr 28 2014 2 junior scholastic answers april 28 2014 2023 09 04 pullmann started tugging on a thread of reports from worried parents and frustrated teachers and it led to a big tangle of history and politics intrigue and arrogance she unwound

it to

[pdf junior scholastic answer keys 2014 braincandy.com](#) - Jul 20 2023

web feb 27 2023 junior scholastic answer keys 2014 right here we have countless books junior scholastic answer keys 2014 and collections to check out we additionally allow variant types and along with type of the books to browse the customary book fiction history novel scientific research as competently as various new

junior scholastic crossword answers march 2014 web mei - Apr 17 2023

web junior scholastic crossword answers march 2014 but end happening in harmful downloads rather than enjoying a fine book once a mug of coffee in the afternoon instead they juggled afterward some harmful virus inside their computer junior scholastic crossword answers march 2014 is

answer keys scholastic - May 18 2023

web answer keys looking for answers on each issue page and article page you can now download answer keys hidden from your students issue archive looking for scope s answer keys

junior scholastic answer keys 2014 2023 discover designlights - Sep 10 2022

web discover junior scholastic jose contreras 2014 scholastic outstanding educator award finalist laurie toledo 2014 scholastic outstanding educator award finalist scholastic com george clement 2014 scholastic outstanding educator award finalist darlens cejour 2014 scholastic all star award finalist kid s book read aloud

junior scholastic crossword puzzle answers march 2014 - Aug 09 2022

web junior scholastic crossword puzzle answers march 2014 game on more awesome activities for clever kids aug 19 2021 the follow up to game on awesome activities for clever kids this book serves up a second helping of baffling brain games for ages 8 to 12 more than 100 colorful puzzles feature all

junior scholastic magazine current events magazine for - Feb 15 2023

web junior scholastic magazine has everything you need to bring current events into your classroom age appropriate news stories social studies connections media literacy features and more

junior scholastic answer keys 2014 kwame alexander - Nov 12 2022

web junior scholastic answer keys 2014 recognizing the artifice ways to get this ebook junior scholastic answer keys 2014 is additionally useful you have remained in right site to begin getting this info get the junior scholastic answer keys 2014 associate that we offer here and check out the link

[juniorscholasticanswers2014](#) - Aug 21 2023

web master the 2014 curriculum with scholastic s 100 lessons the new national curriculum has these books answer my prayers having thank you scholastic for a fantastic resource steven gibson hyde park junior school plymouth scholastic year

in sports 2015 jul 05 2023 the must have book for sports fans of all ages

junior scholastic answers 17 2014 2023 - Mar 04 2022

web junior scholastic answers 17 2014 right here we have countless ebook junior scholastic answers 17 2014 and collections to check out we additionally present variant types and afterward type of the books to browse the normal book fiction history novel scientific research as skillfully as various extra sorts of books are readily

free junior scholastic skills manual answer keys 2014 - Mar 16 2023

web junior scholastic skills manual answer keys 2014 math 65 2e answer key tests sep 15 2020 5 steps to a 5 ap psychology worktexts chapter tests the end of year test and the cumulative review lessons mcgraw hill s gmat 2014 edition feb 13 2023 we want to help you succeed on the gmat we ve put all of our proven expertise into

junior scholastic answer keys 2014 full pdf - Jan 14 2023

web junior scholastic answer keys 2014 the debate on probable opinions in the scholastic tradition may 07 2023 a portrait of scholastic approaches to a qualified disagreement of opinions focusing on the antagonism of scholastic probabilism and anti probabilism in the early modern era the cornerstone jan 23 2022

junior scholastic april 28 2014 answers pdf free support ortax - Jul 08 2022

web anne e cunningham phd 2014 in book smart how to support successful motivated readers the experience of reading together is used as a vehicle for discussing the varied yet interconnected language and literacy skills that jumpstart the career of

junior scholastic answers march 17 2014 2022 web mei - Oct 11 2022

web mar 17 2014 guide junior scholastic answers march 17 2014 it will not say you will many become old as we accustom before you can pull off it even though fake something else at house and even in your workplace hence easy so are you question just exercise just what we meet the expense of under as with ease as review junior scholastic

junior scholastic skills manual answer keys 2014 pdf - May 06 2022

web junior scholastic skills manual answer keys 2014 junior scholastic skills manual answer keys 2014 2 downloaded from ead3 archivists org on 2021 03 06 by guest age 8 are not acknowledged as a workforce unified by the common knowledge and competencies needed to do their jobs well transforming the workforce for children birth

answer keys scholastic - Sep 22 2023

web answer keys you can find the answer key for all of the activities in every issue by clicking answer key at the top of the issue page next summer access where you can find answer keys for every article and issue

junior scholastic skills manual answer keys 2014 web mei - Dec 13 2022

web this on line revelation junior scholastic skills manual answer keys 2014 as without difficulty as review them wherever

you are now april 12 2010 junior scholastic scholastic com

scholastic success with grammar grade 4 pdf verb scribd - Jun 07 2022

web 12 scholastic success with grammar grade 4 compound subjects and predicates a fill in the bubble next to the b fill in the bubble next to the lpln uni rband0001 se compound subject compound predicate 4596 customer scholastic job number 08 12 98 created by cs date he deer and bison grazed in the high 1

magazine issue archive junior scholastic magazine - Jun 19 2023

web april 2023 march 2023 february 2023 january 2023 december 2022 november 2022 november 2022 of 6 browse the full archive of issues from junior scholastic magazine

electron energy and light the emission of light by hydrogen - Feb 08 2023

web view homework help electron energy and light answer key from social science 0034 at fairborn high school

electron energy and light worksheet answer key 2020 2023 - Apr 29 2022

web feb 15 2013 electron energy and light answers pdf b which color corresponds to the strongest energy weakest c explain relationship between brainly ph solved the

electron energy and light chemistry worksheet answers - Sep 03 2022

web send electron energy and light pogil answers pdf via email link or fax you can also download it export it or print it out how to edit pogil ish light waves answer key in pdf

electron energy and light fillable 2 pdf electron - Oct 04 2022

web answer key chapter 5 electrons in atoms 5 1 properties of light check your understanding 1 what are the general properties of light answer light has color and

electron energy and light answer key pdf filler - Dec 26 2021

web electron energy and light worksheet answer key pogil electron energy and light worksheet answer key pogil answers post navigation previous 8 foot ceiling foyer

electron energy and light key form signnow - Feb 25 2022

web apr 20 2023 overview of electron energy and light worksheet answer key pogil electron energy and light worksheet answer key pogil is a comprehensive resource

electron energy and light worksheet answers - Jan 27 2022

web online statement electron energy and light answer key can be one of the options to accompany you taking into account having new time it will not waste your time allow

electron energy and light worksheet answer key 2020 2023 - Mar 29 2022

web fill electron energy and light answer key edit online sign fax and printable from pc ipad tablet or mobile with pdf filler

instantly try now

electron energy and light pogil answer key pdf course hero - Jan 07 2023

web electron energy and light 1 electron energy and light how does light reveal the behavior of electrons in an atom why from fireworks to stars the color of light is

electron energy and light pogil - Mar 09 2023

web view electron energy and light pogil answer key pdf from science 7322 9 at carroll high school fort wayne

electron energy and light key2 course hero - Aug 02 2022

web how to fill out and sign electron energy and light worksheet answer key online get is online document and fill it in employing progressive properties enjoy smart fillable fields

light electromagnetic waves the electromagnetic - Apr 10 2023

web electron energy and light 1 electron energy and light how does light reveal the behavior of electrons in an atom why from fireworks to stars the color of light is

electron energy and light - Aug 14 2023

web electron energy and light how does light reveal the behavior of electrons in an atom why from fireworks to stars the color of light is useful in finding out what's in matter

electron energy and light answer key - Oct 24 2021

electron energy and light worksheet answer key 2020 - Nov 05 2022

web which of the electron transitions involves the most energy n 6 to n 2 violet light 410 nm h explain why this transition involves the most energy based on your

electron energy and light worksheet answer key pogil - Sep 22 2021

photoelectric effect article photons khan academy - May 11 2023

web electron energy and light electron energy and light how does light reveal the behavior of electrons in an atom why from fireworks to stars the color of light is useful in

electron energy and light answer key course hero - Dec 06 2022

web oct 18 2018 the electron energy and light chemistry worksheet answers is an essential part of any chemistry class providing students with a comprehensive overview

key electron energy and light pogil pdf google sheets - Jul 13 2023

web no preview available

[12 electron energy and light t weebly](#) - Jun 12 2023

web title 12 electron energy and light t pdf created date 10 23 2014 11 14 42 pm

[electron energy and light pogil pdf fill out sign online dochub](#) - May 31 2022

web quick guide on how to complete electron energy and light worksheet answer key forget about scanning and printing out forms use our detailed instructions to fill out and esign

electron energy and light worksheet answer key pogil - Nov 24 2021

[ck 12 chemistry basic answer key chapter 5 electrons in atoms](#) - Jul 01 2022

web it takes only a few minutes the answer has to do with energy levels of atoms what what energy levels energetic levels also called electron shells are fixed distances from