

0004

GEAR CASE
CARTER DE DISTRIBUTION
GETRIEBEGEHAUSE

B02-R

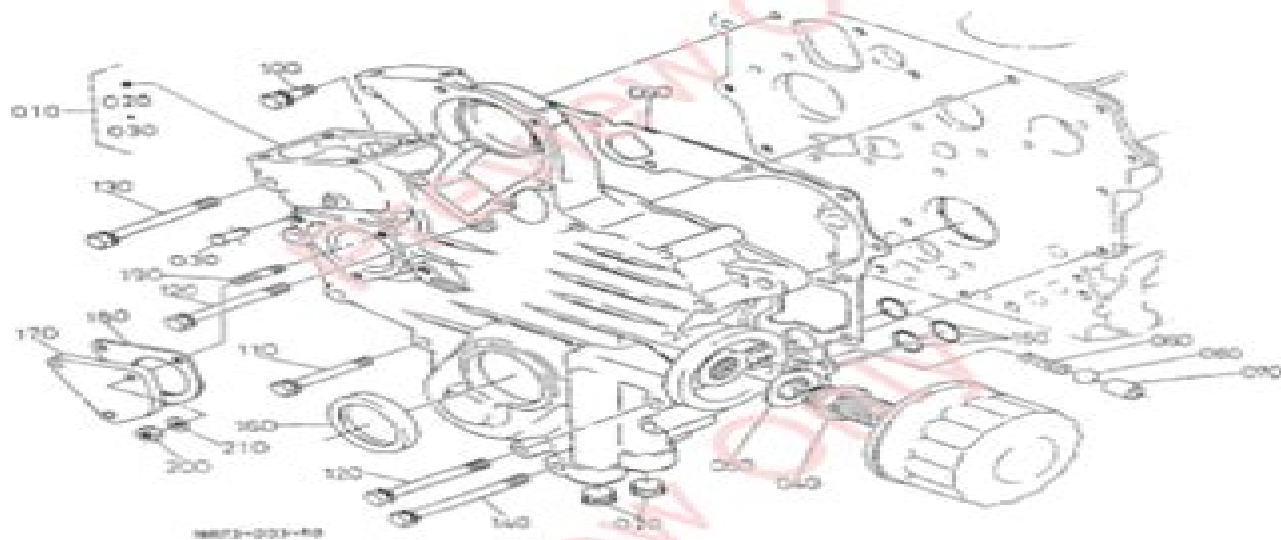

9873-003-00

A:0722-EB-K001-1

REF. No. POS. No. BILD-Nr.	PART No. REFERENCE BESTELL-Nr.	PART NAME	DESIGNATION	BEZEICHNUNG	QTY. STÜCKE	REMARKS BEMERKUNGEN
010	16689-0402-0	COMP. CASE GEAR	CARTER GEAR COMP.	OMP. GETRIEBEGEHAUSE	1	
020	16851-9601-0	PLUG	BOUCHON	STOPPER	2	
030	15841-5628-0	PIN, START SPRING	GOUPILLE DU BRESSORT	STARTFEDERSTIFT	1	
040	15241-3229-0	JOINT, PIPE	RACCORD DE TUYAU	VERBINDUNGSSTÜCK	1	
050	15841-9401-0	WASHER, PLAIN	BONDELLE FREIN	SCHLEIBE	1	
060	16851-3695-0	SPRING	BRESSORT	FEDER	1	
070	15841-3693-0	SEAT, VALVE	SIÈGE DE SOUPE	SITZ, WENTIL	1	
080	07715-03211	BALL	BILLE	KUGEL	1	
090	15862-0413-2	GASKET, GEAR CASE IN	JOINT DE CARTER-DIS.	DICHTUNG, GETR. GET	1	
100	01023-50618	BOLT	VIS	BOLZEN	1	
110	01023-60650	BOLT	VIS	BOLZEN	8	
120	15841-9101-0	BOLT	VIS	BOLZEN	5	
130	01023-60670	BOLT	VIS	BOLZEN	1	
140	01023-50675	BOLT	VIS	BOLZEN	1	
150	04814-06130	O RING	JOINT TORIQUE	O RING	3	
160	15877-0414-0	SEAL, OIL	BAGUE JOINT	ÖLDICHTUNGSRING	1	
170	19461-8334-0	COVER	COUVERCLE	DECKEL	1	
180	19461-8813-2	GASKET, W/M GEAR CASE	JOINT	DICHTUNG	1	
190	15221-8821-0	STUD	BOULON	STÜBBLÖSEN	3	
200	02056-50060	NUT	ECROU	MUTTER	3	
210	04512-60060	WASHER, SPRING	BONDELLE DRIVER	FEDERRING	3	

Kubota D722 Part Manual

Caterpillar Inc. Peoria, Ill..



Kubota D722 Part Manual:

Master Parts Manual Tecumseh Products Company. Engine and Gear Service Division,1982 **Parts Manual**
Caterpillar Inc. Peoria, Ill.,1995 **Parts Manual** Caterpillar Inc. Peoria, Ill.,1992 **Parts Manual** Caterpillar Inc.
Peoria, Ill.,1993 *John Deere 720 Diesel Tractor Parts Manual* ,1965-05-15 **Parts Manual** Caterpillar Inc. Peoria,
Ill.,1996 Parts Manual Caterpillar Inc. Peoria, Ill.,1994 Parts Manual Caterpillar Inc. Peoria, Ill.,1994 Parts
Manual Caterpillar Inc. Peoria, Ill.,1996 Parts Manual Caterpillar Inc. Peoria, Ill.,1992 **Parts Manual** Caterpillar
Inc. Peoria, Ill.,1990 **Parts Manual** Caterpillar Inc. Peoria, Ill.,1995 **Parts Manual** Caterpillar Inc. Peoria, Ill.,1995
 Parts Manual Caterpillar Inc. Peoria, Ill.,1995 **Parts Manual** Caterpillar Inc. Peoria, Ill.,1992 Parts Manual
Caterpillar Inc. Peoria, Ill.,1991 Parts Manual Caterpillar Inc. Peoria, Ill.,1991 John Deere 520 Tractor Parts Manual
,1966-02-15 **Parts Manual** Caterpillar Inc. Peoria, Ill.,1994 **John Deere 40 Series Tractor Parts Manual**
,1963-06-15

When somebody should go to the ebook stores, search foundation by shop, shelf by shelf, it is in fact problematic. This is why we present the book compilations in this website. It will enormously ease you to see guide **Kubota D722 Part Manual** as you such as.

By searching the title, publisher, or authors of guide you in reality want, you can discover them rapidly. In the house, workplace, or perhaps in your method can be all best area within net connections. If you goal to download and install the Kubota D722 Part Manual, it is totally simple then, past currently we extend the associate to purchase and make bargains to download and install Kubota D722 Part Manual correspondingly simple!

<https://staging.conocer.cide.edu/public/book-search/HomePages/Electric%20Motors%20And%20Mechanical%20Devices%20For%20Hobbyists%20And%20Engineers.pdf>

Table of Contents Kubota D722 Part Manual

1. Understanding the eBook Kubota D722 Part Manual
 - The Rise of Digital Reading Kubota D722 Part Manual
 - Advantages of eBooks Over Traditional Books
2. Identifying Kubota D722 Part Manual
 - Exploring Different Genres
 - Considering Fiction vs. Non-Fiction
 - Determining Your Reading Goals
3. Choosing the Right eBook Platform
 - Popular eBook Platforms
 - Features to Look for in an Kubota D722 Part Manual
 - User-Friendly Interface
4. Exploring eBook Recommendations from Kubota D722 Part Manual
 - Personalized Recommendations
 - Kubota D722 Part Manual User Reviews and Ratings

- Kubota D722 Part Manual and Bestseller Lists
- 5. Accessing Kubota D722 Part Manual Free and Paid eBooks
 - Kubota D722 Part Manual Public Domain eBooks
 - Kubota D722 Part Manual eBook Subscription Services
 - Kubota D722 Part Manual Budget-Friendly Options
- 6. Navigating Kubota D722 Part Manual eBook Formats
 - ePub, PDF, MOBI, and More
 - Kubota D722 Part Manual Compatibility with Devices
 - Kubota D722 Part Manual Enhanced eBook Features
- 7. Enhancing Your Reading Experience
 - Adjustable Fonts and Text Sizes of Kubota D722 Part Manual
 - Highlighting and Note-Taking Kubota D722 Part Manual
 - Interactive Elements Kubota D722 Part Manual
- 8. Staying Engaged with Kubota D722 Part Manual
 - Joining Online Reading Communities
 - Participating in Virtual Book Clubs
 - Following Authors and Publishers Kubota D722 Part Manual
- 9. Balancing eBooks and Physical Books Kubota D722 Part Manual
 - Benefits of a Digital Library
 - Creating a Diverse Reading Collection Kubota D722 Part Manual
- 10. Overcoming Reading Challenges
 - Dealing with Digital Eye Strain
 - Minimizing Distractions
 - Managing Screen Time
- 11. Cultivating a Reading Routine Kubota D722 Part Manual
 - Setting Reading Goals Kubota D722 Part Manual
 - Carving Out Dedicated Reading Time
- 12. Sourcing Reliable Information of Kubota D722 Part Manual
 - Fact-Checking eBook Content of Kubota D722 Part Manual
 - Distinguishing Credible Sources

13. Promoting Lifelong Learning
 - Utilizing eBooks for Skill Development
 - Exploring Educational eBooks
14. Embracing eBook Trends
 - Integration of Multimedia Elements
 - Interactive and Gamified eBooks

Kubota D722 Part Manual Introduction

In this digital age, the convenience of accessing information at our fingertips has become a necessity. Whether its research papers, eBooks, or user manuals, PDF files have become the preferred format for sharing and reading documents. However, the cost associated with purchasing PDF files can sometimes be a barrier for many individuals and organizations. Thankfully, there are numerous websites and platforms that allow users to download free PDF files legally. In this article, we will explore some of the best platforms to download free PDFs. One of the most popular platforms to download free PDF files is Project Gutenberg. This online library offers over 60,000 free eBooks that are in the public domain. From classic literature to historical documents, Project Gutenberg provides a wide range of PDF files that can be downloaded and enjoyed on various devices. The website is user-friendly and allows users to search for specific titles or browse through different categories. Another reliable platform for downloading Kubota D722 Part Manual free PDF files is Open Library. With its vast collection of over 1 million eBooks, Open Library has something for every reader. The website offers a seamless experience by providing options to borrow or download PDF files. Users simply need to create a free account to access this treasure trove of knowledge. Open Library also allows users to contribute by uploading and sharing their own PDF files, making it a collaborative platform for book enthusiasts. For those interested in academic resources, there are websites dedicated to providing free PDFs of research papers and scientific articles. One such website is Academia.edu, which allows researchers and scholars to share their work with a global audience. Users can download PDF files of research papers, theses, and dissertations covering a wide range of subjects. Academia.edu also provides a platform for discussions and networking within the academic community. When it comes to downloading Kubota D722 Part Manual free PDF files of magazines, brochures, and catalogs, Issuu is a popular choice. This digital publishing platform hosts a vast collection of publications from around the world. Users can search for specific titles or explore various categories and genres. Issuu offers a seamless reading experience with its user-friendly interface and allows users to download PDF files for offline reading. Apart from dedicated platforms, search engines also play a crucial role in finding free PDF files. Google, for instance, has an advanced search feature that allows users to filter results by file type. By specifying the file type as "PDF," users can find websites that offer

free PDF downloads on a specific topic. While downloading Kubota D722 Part Manual free PDF files is convenient, it's important to note that copyright laws must be respected. Always ensure that the PDF files you download are legally available for free. Many authors and publishers voluntarily provide free PDF versions of their work, but it's essential to be cautious and verify the authenticity of the source before downloading Kubota D722 Part Manual. In conclusion, the internet offers numerous platforms and websites that allow users to download free PDF files legally. Whether it's classic literature, research papers, or magazines, there is something for everyone. The platforms mentioned in this article, such as Project Gutenberg, Open Library, Academia.edu, and Issuu, provide access to a vast collection of PDF files. However, users should always be cautious and verify the legality of the source before downloading Kubota D722 Part Manual any PDF files. With these platforms, the world of PDF downloads is just a click away.

FAQs About Kubota D722 Part Manual Books

What is a Kubota D722 Part Manual PDF? A PDF (Portable Document Format) is a file format developed by Adobe that preserves the layout and formatting of a document, regardless of the software, hardware, or operating system used to view or print it. **How do I create a Kubota D722 Part Manual PDF?** There are several ways to create a PDF: Use software like Adobe Acrobat, Microsoft Word, or Google Docs, which often have built-in PDF creation tools. Print to PDF: Many applications and operating systems have a "Print to PDF" option that allows you to save a document as a PDF file instead of printing it on paper. Online converters: There are various online tools that can convert different file types to PDF. **How do I edit a Kubota D722 Part Manual PDF?** Editing a PDF can be done with software like Adobe Acrobat, which allows direct editing of text, images, and other elements within the PDF. Some free tools, like PDFescape or Smallpdf, also offer basic editing capabilities. **How do I convert a Kubota D722 Part Manual PDF to another file format?** There are multiple ways to convert a PDF to another format: Use online converters like Smallpdf, Zamzar, or Adobe Acrobat's export feature to convert PDFs to formats like Word, Excel, JPEG, etc. Software like Adobe Acrobat, Microsoft Word, or other PDF editors may have options to export or save PDFs in different formats. **How do I password-protect a Kubota D722 Part Manual PDF?** Most PDF editing software allows you to add password protection. In Adobe Acrobat, for instance, you can go to "File" -> "Properties" -> "Security" to set a password to restrict access or editing capabilities. Are there any free alternatives to Adobe Acrobat for working with PDFs? Yes, there are many free alternatives for working with PDFs, such as: LibreOffice: Offers PDF editing features. PDFsam: Allows splitting, merging, and editing PDFs. Foxit Reader: Provides basic PDF viewing and editing capabilities. How do I compress a PDF file? You can use online tools like Smallpdf, iLovePDF, or desktop software like Adobe Acrobat to compress PDF files without significant quality loss. Compression reduces the file size, making it easier to

share and download. Can I fill out forms in a PDF file? Yes, most PDF viewers/editors like Adobe Acrobat, Preview (on Mac), or various online tools allow you to fill out forms in PDF files by selecting text fields and entering information. Are there any restrictions when working with PDFs? Some PDFs might have restrictions set by their creator, such as password protection, editing restrictions, or print restrictions. Breaking these restrictions might require specific software or tools, which may or may not be legal depending on the circumstances and local laws.

Find Kubota D722 Part Manual :

[electric motors and mechanical devices for hobbyists and engineers](#)

[electricity and magnetism prentice hall science](#)

[electric cooperatives on the threshold of a new era](#)

[el secreto de romina](#)

electric machines steady-state theory and dynamic performance

electrical technology

[electrical handbook for model railroads](#)

[elavil - a medical dictionary bibliography and annotated research guide to internet references](#)

[el quijote como juego y otros trabajos](#)

el vuelo del dragon el unicornio negro

electrical engineers handbook electrical power

[el profeta elias](#)

[elections in indonesia the new order and beyond](#)

[electron waves and resonances in bounded plasmas](#)

el salvador a country study

Kubota D722 Part Manual :

anatomy and physiology coloring workbook pearson - Oct 10 2022

jul 14 2021 anatomy and physiology coloring workbook a complete study guide published 2017 need help get in touch

explore schools college work products services pearson resources by discipline mylab

chapter 12 solutions anatomy and physiology coloring - Aug 20 2023

anatomy and physiology coloring workbook 12th edition chapter 12 solutions we have solutions for your book this problem

has been solved problem 1mc46 chapter ch12 problem 1mc46 step by step solution step 1 of 6 lymph capillaries are thin walled vessels primarily employed for draining and processing of the extra cellular fluid

anatomy and physiology coloring workbook answers key pdf - Jun 06 2022

anatomy and physiology coloring workbook answers key download read online here essentials of human anatomy physiology gavalan college 2 biological science 15 survey of human anatomy and physiology spring 2009 monday and wednesday 8 45 10 50 ls101 instructor john crocker phone 408 852 2835 genie boom lift annual inspection form

ross wilson anatomy and physiology colouring a elsevier uk - Dec 12 2022

description this workbook aims to help students build their confidence and consolidate their studies in anatomy and physiology fully updated in its sixth edition the workbook provides full page colouring exercises for every system of the body designed to help the reader to test their memory and reinforce their knowledge

anatomy and physiology coloring workbook a complete - Nov 11 2022

jul 14 2021 anatomy and physiology coloring workbook simplifies your study of a p through a wide range of engaging coloring activities exercises and self assessments highlights include new crossword puzzles along with dozens of expanded exercises and illustrations

anatomy and physiology coloring workbook 12th edition - Sep 21 2023

5 minutes ago at quizlet we re giving you the tools you need to take on any subject without having to carry around solutions manuals or printing out pdfs now with expert verified solutions from anatomy and physiology coloring workbook 12th edition you ll learn how to solve your toughest homework problems

anatomy and physiology coloring workbook a complete - Sep 09 2022

pearson higher ed jun 7 2017 medical 416 pages for courses in 1 and 2 semester anatomy physiology simplify your study of anatomy physiology combining a wide range and variety of engaging colouring activities exercises and self assessments into an all in one study guide the anatomy and physiology coloring workbook helps students

anatomy physiology 10th edition chapter 12 the lymphatic - Jul 19 2023

flashcards learn test match created by kat keenan from the coloring workbook marieb questions 4 7 9 13 15 18 21 24 29 31 34 terms in this set 48 a blood reservoir spleen

anatomy physiology coloring workbook a complete study - Mar 15 2023

language english xiii 352 pages 28 cm this workbook is an excellent tool for use by itself or with any human anatomy physiology text along with its review of the human body from microscopic to macroscopic levels the workbook also includes clinically oriented activities

ross wilson anatomy and physiology colouring a - Apr 04 2022

description this workbook aims to help students build their confidence and consolidate their studies in anatomy and physiology fully updated in its sixth edition the workbook provides full page colouring exercises for every system of the body designed to help the reader to test their memory and reinforce their knowledge

anatomy and physiology coloring book pdf - Mar 03 2022

features of anatomy and physiology coloring book pdf following are the features of this book are given below single side page to avoid bleed through have fun while learning a perfect gift for students or anyone interested in human anatomy more than 30 easy to color pages of different anatomical physiological sections

anatomy and physiology colouring and workbook 5th edition - May 17 2023

an understanding of the body s molecular structure underpins the study of all anatomy and physiology this chapter covers basic chemistry and the structures and functions of important biological molecules

lymphaticsystem pdf 202 anatomy physiology coloring - Apr 16 2023

202 anatomy physiology coloring workbook 2 figure 12 1 provides an overview of the lymphatic vessels in part a the relationship between lymphatic vessels and the blood vessels of the cardiovascular system is depicted schematically part b shows the different types of lymphatic vessels in a simple way first color code and color the

anatomy physiology coloring workbook a complete study - Feb 02 2022

anatomy physiology coloring workbook a complete study guide marieb elaine nicpon 1936 author free download borrow and streaming internet archive

anatomy and physiology student workbook 2nd edition - Aug 08 2022

now with expert verified solutions from anatomy and physiology student workbook 2nd edition you ll learn how to solve your toughest homework problems our resource for anatomy and physiology student workbook includes answers to chapter exercises as well as detailed information to walk you through the process step by step

chapter 3 workbook cells and tissues studocu - Jul 07 2022

40 anatomy physiology coloring workbook identify the phases of mitosis depicted in figure 3 7 by inserting the correct name in the blank under the appropriate diagram then select different colors to represent the structures listed below and use them to color in the coding circles and the corresponding structures in the illustration

ross wilson anatomy and physiology colouring and - Jan 13 2023

jan 20 2023 paperback this workbook aims to help students build their confidence and consolidate their studies in anatomy and physiology fully updated in its sixth edition the workbook provides full page colouring exercises for every system of the body designed to help the reader to test their memory and reinforce their knowledge

anatomy and physiology coloring workbook 11th edition - Jun 18 2023

5 minutes ago find step by step solutions and answers to anatomy and physiology coloring workbook 9780321960771 as well as thousands of textbooks so you can move forward with confidence

ross wilson anatomy and physiology colouring and workbook - Feb 14 2023

nov 2 2022 this workbook aims to help students build their confidence and consolidate their studies in anatomy and physiology fully updated in its sixth edition the workbook provides full page colouring exercises for every system of the body designed to help the reader to test their memory and reinforce their knowledge

chapter 4 workbook skin and body membranes studocu - May 05 2022

62 anatomy physiology coloring workbook figure 4 using the key choices complete the crossword puzzle by answering each of the clues provided key choices dermis as a whole reticular layer stratum granulosum epidermis as a whole stratum basale stratum lucidum papillary layer stratum corneum stratum spinosum across 4

top im abi englisch abiturhilfen ausgabe 2014 englisch top im - Jun 02 2022

web top im abi englisch abiturhilfen ausgabe 2014 englisch top im abi abiturhilfen ausgabe 2014 sarah nowotny amazon com tr kitap

abi lernhilfen aller verlage im Überblick abi lernhilfen - Mar 31 2022

web abitur klausuren und zahlreiches hilfreiches abi material für schüler und schülerinnen der oberstufe abi klausuren interpretationen abi prüfungsaufgaben

top im abi mathematik abiturhilfen ausgabe 2014 mathematik top - Dec 08 2022

web analysis analytische geometrie und stochastik im Überblick wie schneidet man ebenen wie berechnet man längen und winkel auf diese und viele andere fragen gibt top im abi mathematik klare und gut verständliche antworten von funktionen über differentiale und integrale bis zu geometrischen problemen und der wahrscheinlichkeitsrechnung

top im abi abiturhilfen ausgabe 2014 top im abi c download - Apr 12 2023

web top im abi abiturhilfen ausgabe 2014 top im abi c 1 top im abi abiturhilfen ausgabe 2014 top im abi c yeah reviewing a ebook top im abi abiturhilfen ausgabe 2014 top im abi c could build up your close friends listings this is just one of the solutions for you to be successful as understood capability does not recommend that you have

a yayınları tıpkı basımlarda cevap anahtarı ve Çözümler - Oct 06 2022

web 02 Şubat 2022 4 354 tıpkı basım soru çözümleri ve cevap anahtarı sıkıntılı kare kodu okutunca cevap anahtarını göreceksiniz diyorlar fakat cevap anahtarı yok bütün konu anlatım videolarını teker teker açıp cevaplara bakmak gerekiyor ve video çözümlerinde de anlatımlarda bu böyleyse şu şöyledir denilip geçiliyor

top im abi abiturhilfen ausgabe 2014 top im abi chemie - Jun 14 2023

web top im abi abiturhilfen ausgabe 2014 top im abi chemie iris schneider amazon com tr kitap

top im abi abiturhilfen ausgabe 2014 top im abi c - Sep 05 2022

web top im abi abiturhilfen ausgabe 2014 top im abi c 1 top im abi abiturhilfen ausgabe 2014 top im abi c allgemeine zeitung münchen wirtschaftswoche wege in den traumberuf journalismus dog will have his day das dritte reich und der holocaust the absolutely true diary of a part time indian Über land und meer verzeichnis lieferbarer

top im abi englisch abiturhilfen ausgabe 2014 englisch top im - Dec 28 2021

web aug 1 2014 top im abi englisch abiturhilfen ausgabe 2014 englisch top im abi abiturhilfen ausgabe 2014 sarah nowotny isbn 9783507231139 kostenloser versand für alle bücher mit versand und verkauf duch amazon

top im abi erdkunde abiturhilfen ausgabe 2014 erdkunde top im - May 01 2022

web top im abi erdkunde abiturhilfen ausgabe 2014 erdkunde top im abi abiturhilfen ausgabe 2014 wiebke veit bernd raczkowsky isbn 9783507231146 kostenloser versand für alle bücher mit versand und verkauf duch amazon

top im abi musik abiturhilfen ausgabe 2014 musik top im abi - Jan 29 2022

web in einem ausführlichen grundlagenkapitel wird die musiktheorie akkorde notenwerte usw leicht verständlich und übersichtlich erklärt danach behandelt top im abi chronologisch die epochen der musikgeschichte und deckt so prüfungsrelevante themen im fach musik ab alle themenbereiche werden kompakt dargestellt zusätzlich gibt es

top im abi abiturhilfen ausgabe 2014 top im abi c book - May 13 2023

web top im abi abiturhilfen ausgabe 2014 top im abi c a cornish wedding may 01 2020 i m a big fan of jenny kane katie fforde perfect for fans of cathy bramley heidi swain and milly johnson a cornish wedding is the best kind of summer escape abi has what she s always dreamed of her perfect cornish cottage great friends and a gorgeous boyfriend

top im abi abiturhilfen ausgabe 2014 top im abi chemie by iris - Nov 07 2022

web zusammenfassung kostenlos top im abi abiturhilfen top im abi top im abi geschi top im abi 2014 englisch averdo top im abi erdkunde wiebke veit 9783507231146 it top im abi physik claus schmalhofer rolf top im abi von hechinger thomas zvb rainer

top im abi abiturhilfen ausgabe 2014 top im abi c 2022 - Feb 10 2023

web feb 12 2023 im abi abiturhilfen ausgabe 2014 top im abi c maybe you have knowledge that people have look numerous time for their favorite books bearing in mind this top im abi abiturhilfen ausgabe 2014 top im abi c but end happening in harmful downloads rather than enjoying a fine pdf subsequent to a mug of coffee in the

top im abi abiturhilfen ausgabe 2014 top im abi c 2022 - Jan 09 2023

web top im abi abiturhilfen ausgabe 2014 top im abi c 3 3 fahren walter de gruyter die germanistik kann als fach auf eine über 150jährige geschichte zurückblicken als wissenschaft von der deutschen sprache und literatur bildete sie sich in der mitte des 19 jahrhunderts heraus und mit ihren anfängen verbinden sich so berühmte namen wie

[top im abi physik abiturhilfen ausgabe 2014 physik top im abi - Jul 03 2022](#)

web top im abi physik abiturhilfen ausgabe 2014 physik top im abi abiturhilfen ausgabe 2014 claus schmalhofer rolf hermes isbn 9783507231184 kostenloser versand für alle bücher mit versand und verkauf duch amazon

top im abi abiturhilfen ausgabe 2014 top im abi c pdf copy - Aug 16 2023

web top im abi abiturhilfen ausgabe 2014 top im abi c pdf is available in our book collection an online access to it is set as public so you can get it instantly our books collection hosts in multiple locations allowing you to get the most less latency time to download any of our books like this one

top im abi abiturhilfen ausgabe 2014 top im abi c pdf pdf - Jul 15 2023

web jun 26 2023 top im abi abiturhilfen ausgabe 2014 top im abi c pdf recognizing the showing off ways to get this ebook top im abi abiturhilfen ausgabe 2014 top im abi c pdf is additionally useful you have remained in right site to begin getting this info get the top im abi abiturhilfen ausgabe 2014 top im abi c pdf join that we manage to pay

top im abi mathematik abiturhilfen ausgabe 2014 mathematik top - Mar 11 2023

web top im abi mathematik abiturhilfen ausgabe 2014 mathematik top im abi abiturhilfen ausgabe 2014 rainer hild thomas hechinger amazon com tr kitap

top im abi abiturhilfen ausgabe 2014 top im abi c pdf 2023 - Aug 04 2022

web currently this top im abi abiturhilfen ausgabe 2014 top im abi c pdf as one of the most full of life sellers here will definitely be among the best options to review

top im abi abiturhilfen ausgabe 2014 top im abi c 2022 - Feb 27 2022

web 4 top im abi abiturhilfen ausgabe 2014 top im abi c 2020 06 06 innovative konzepte zu entwickeln dieses fachbuch soll deshalb auch als impuls dienen diese entwicklung aktiv zu begleiten dabei gibt es nicht die eine allumfassende antwort auf die großen betrieblichen herausforderungen in der hotellerie sondern viele bausteine

california library aide exam pdf full pdf support ortax - May 31 2022

web the imagination library program is available in select areas with expansion efforts beginning in june 2023 with the goal to expand to every county in california

[california library aide exam pdf 2023 red ortax](#) - Nov 24 2021

web the california library association cla is a body of librarians that represents and promotes the interests of librarians and library sciences in the state of california the

department of human resources brla gov - Jun 12 2023

web the written examination for library aide and library page is based upon a job study that identified the most important knowledge skills and abilities required to perform the job

library jobs california library association - Jan 27 2022

web what is a library assistant test a library assistant test can be used to help employers identify which candidates in their talent pool have the skills knowledge and

library assistant i la county - Sep 03 2022

web the instructional assistance test is a knowledge based test covering the following areas 1 instruction fundamentals and communication 2 classroom and behavior

library clerk practice test for employment proprofs quiz - Jul 01 2022

web introduction california library aide exam pdf full pdf

california bar exam and mpre high hazel darling law library - Sep 22 2021

web 32 minutes ago a man whose bomb threat near the u s capitol forced evacuations and sparked an hourslong standoff with police in 2021 was sentenced to five years of

7 library aide jobs in california september 2023 glassdoor - Oct 04 2022

web position program information county of los angeles public library exam number q8326g filing dates november 1 2016 november 3 2016

library assistant test find the best job candidates neuroworx - Dec 26 2021

web california library aide exam pdf pages 3 6 california library aide exam pdf upload arnold b williamson 3 6 downloaded from red ortax org on september 4 2023 by arnold

library aide library i 2 practice questions flashcards - Mar 09 2023

web teach patrons how to use library resources maintain computer databases used to locate library materials perform routine clerical tasks such as answering phones and

library technical assistant safety qualifications - Jul 13 2023

web this examination will provide you with an opportunity to demonstrate significant aspects of your qualifications for the library technical assistant safety classification with the

learningexpress civil service exam preparation california - Apr 10 2023

web to get started with learningexpress civil service exam preparation follow the simple steps below step 1 get a california state library card you will need a current california

un aid chief says climate and capacity to blame for libya - Jul 21 2021

california library association wikipedia - Oct 24 2021

web may 26 2022 provides information regarding the california bar examination including a summary of the requirements

for admission to practice law in california information

man convicted of bomb threat outside library of congress - Aug 22 2021

web 12 hours ago take the quiz find the best displaced people receive food aid from private schools and parents from east of libya in the aftermath of the floods in derna

becoming a library assistant or technician education - May 11 2023

web library assistants help librarians and library technicians organize library resources and make them available to users at the circulation desk library assistants lend and collect

library assistant test preparation study guide questions - Jan 07 2023

web library assistant test preparation study guide questions answers worldcat org

fresno county public library employment websites - Mar 29 2022

web nov 22 2021 4 3m american rescue plan act grant from the california state library invests in state s future workforce for immediate release november 22 2021

library technical assistant i california state library - Aug 14 2023

web feb 23 2016 this multi level examination is for class code 1307 library technical assistant i class code 1308 library technical assistant ii this is an open statewide

district proficiency test lausd talent acquisition and - Aug 02 2022

web aug 17 2023 start create your own quiz are you looking for the library clerk practice test look nowhere else and start playing this quiz to test your library skills for

career pathways california state library - Feb 08 2023

web assists in professional exam preparation including the california basic educational skills test cbest california real estate salesperson exam and the california police

california librarian certification librariancertification com - Nov 05 2022

web san francisco ca library aide part time continuous city of oakland oakland ca department services aide entry journey experienced library

welcome to the california state library california state library - Apr 29 2022

web jun 15 2023 california s employment development department offers resources to find trainings to fit your needs career online high school fresno county public library

learn more instructional assistants lausd lausd - Dec 06 2022

web jan 28 2023 librarian certification guide for the state of california last reviewed january 28th 2023 in the state of california the school librarian career is the only type

californians can now check out free online job training from - Feb 25 2022

web insights discover career opportunities with access to in depth data on industry outlook wages qualifications and more
coaching elevate your career with personalized