

# 1B19

ENGINE

TP58464

-UN-080039

## ROCKER ARMS AND VALVES

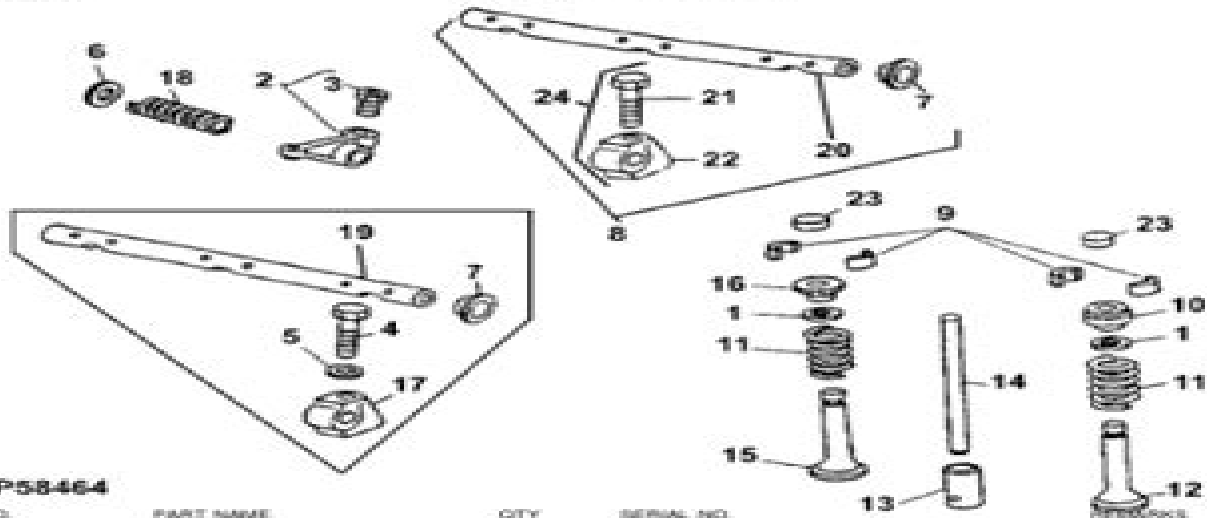

### TP58464

KEY	PART NO.	PART NAME	QTY	SERIAL NO.
1	RS7627	O-RING	4	(GASOLINE) (INTAKE) (SUB FOR RQ7976, THIS APPLICATION)
	RS7627	O-RING	8	(DIESEL) (SUB FOR RQ7976, THIS APPLICATION)
2	RE31973	ROCKER ARM	1	(SUB FOR AT31255, AR150769 AND RE19031)
3	T32213	SCREW	1	(SUB RE31973)
4	19H3031	CAP SCREW	4	3/8" X 2-1/2"
5	R42729	WASHER	4	(SUB FOR T23594)
6	T20316	WASHER	4	
7	T23459	PLUG	1	-173457
	R54525	PLUG	1	173458
8	RE502674	ROCKER ARM SHAFT	1	

# John Deere 410 Backhoe Parts Manual

**DJ Losen**



## **John Deere 410 Backhoe Parts Manual:**

**Operator's, Organizational, Direct Support and General Support Maintenance Manual (including Repair Parts List)** ,1989    Monthly Catalogue, United States Public Documents ,1983    Monthly Catalog of United States Government Publications United States. Superintendent of Documents,1992    **General Construction Equipment Operator** United States. Department of the Army,1979    *Technical Manual* United States Department of the Army,1982    The EBay Price Guide Julia L. Wilkinson,2006 Provides lists of selling prices of items found on eBay in such categories as antiques boats books cameras coins collectibles dolls DVDs real estate stamps tickets and video games    *Farmers and Consumers Market Bulletin* ,2009    **Commerce Business Daily** ,1998-11    **Timber Bulletin** ,2006    **California Farmer** ,1982    *California Builder & Engineer* ,1994    **Public Works Manual** ,1985    Operator's, Organizational, Direct Support and General Support Maintenance Manual (including Repair Parts List) ,1989    **Union Agriculturist and Western Prairie Farmer** ,2001    **The Timber Producer** ,1999    *The Northern Logger and Timber Processor* ,2006    Wallaces Farmer ,1977    **Popular Science** ,1985    **Roads and Streets** ,1969 Issues for include section Bituminous roads and streets    **Direct Support and General Support Maintenance Manual for Tractor, Wheeled, DED, Loader Backhoe, with Hydraulic Impact Tool and with Hydraulic Earth Auger Attachment, John Deere Model JD410 (CCE), with Bucket, Impactor, and Earth Drill (NSN 2420-00-567-0135).** ,1993

The book delves into John Deere 410 Backhoe Parts Manual. John Deere 410 Backhoe Parts Manual is a crucial topic that needs to be grasped by everyone, from students and scholars to the general public. This book will furnish comprehensive and in-depth insights into John Deere 410 Backhoe Parts Manual, encompassing both the fundamentals and more intricate discussions.

1. The book is structured into several chapters, namely:
    - Chapter 1: Introduction to John Deere 410 Backhoe Parts Manual
    - Chapter 2: Essential Elements of John Deere 410 Backhoe Parts Manual
    - Chapter 3: John Deere 410 Backhoe Parts Manual in Everyday Life
    - Chapter 4: John Deere 410 Backhoe Parts Manual in Specific Contexts
    - Chapter 5: Conclusion
  2. In chapter 1, this book will provide an overview of John Deere 410 Backhoe Parts Manual. The first chapter will explore what John Deere 410 Backhoe Parts Manual is, why John Deere 410 Backhoe Parts Manual is vital, and how to effectively learn about John Deere 410 Backhoe Parts Manual.
  3. In chapter 2, this book will delve into the foundational concepts of John Deere 410 Backhoe Parts Manual. The second chapter will elucidate the essential principles that must be understood to grasp John Deere 410 Backhoe Parts Manual in its entirety.
  4. In chapter 3, the author will examine the practical applications of John Deere 410 Backhoe Parts Manual in daily life. The third chapter will showcase real-world examples of how John Deere 410 Backhoe Parts Manual can be effectively utilized in everyday scenarios.
  5. In chapter 4, this book will scrutinize the relevance of John Deere 410 Backhoe Parts Manual in specific contexts. The fourth chapter will explore how John Deere 410 Backhoe Parts Manual is applied in specialized fields, such as education, business, and technology.
  6. In chapter 5, the author will draw a conclusion about John Deere 410 Backhoe Parts Manual. The final chapter will summarize the key points that have been discussed throughout the book.
- This book is crafted in an easy-to-understand language and is complemented by engaging illustrations. This book is highly recommended for anyone seeking to gain a comprehensive understanding of John Deere 410 Backhoe Parts Manual.

<https://staging.conocer.cide.edu/public/Resources/fetch.php/Fostex%20Vm88%20User%20Guide.pdf>

## **Table of Contents John Deere 410 Backhoe Parts Manual**

1. Understanding the eBook John Deere 410 Backhoe Parts Manual
  - The Rise of Digital Reading John Deere 410 Backhoe Parts Manual
  - Advantages of eBooks Over Traditional Books
2. Identifying John Deere 410 Backhoe Parts Manual
  - Exploring Different Genres
  - Considering Fiction vs. Non-Fiction
  - Determining Your Reading Goals
3. Choosing the Right eBook Platform
  - Popular eBook Platforms
  - Features to Look for in an John Deere 410 Backhoe Parts Manual
  - User-Friendly Interface
4. Exploring eBook Recommendations from John Deere 410 Backhoe Parts Manual
  - Personalized Recommendations
  - John Deere 410 Backhoe Parts Manual User Reviews and Ratings
  - John Deere 410 Backhoe Parts Manual and Bestseller Lists
5. Accessing John Deere 410 Backhoe Parts Manual Free and Paid eBooks
  - John Deere 410 Backhoe Parts Manual Public Domain eBooks
  - John Deere 410 Backhoe Parts Manual eBook Subscription Services
  - John Deere 410 Backhoe Parts Manual Budget-Friendly Options
6. Navigating John Deere 410 Backhoe Parts Manual eBook Formats
  - ePub, PDF, MOBI, and More
  - John Deere 410 Backhoe Parts Manual Compatibility with Devices
  - John Deere 410 Backhoe Parts Manual Enhanced eBook Features
7. Enhancing Your Reading Experience
  - Adjustable Fonts and Text Sizes of John Deere 410 Backhoe Parts Manual
  - Highlighting and Note-Taking John Deere 410 Backhoe Parts Manual
  - Interactive Elements John Deere 410 Backhoe Parts Manual

8. Staying Engaged with John Deere 410 Backhoe Parts Manual
  - Joining Online Reading Communities
  - Participating in Virtual Book Clubs
  - Following Authors and Publishers John Deere 410 Backhoe Parts Manual
9. Balancing eBooks and Physical Books John Deere 410 Backhoe Parts Manual
  - Benefits of a Digital Library
  - Creating a Diverse Reading Collection John Deere 410 Backhoe Parts Manual
10. Overcoming Reading Challenges
  - Dealing with Digital Eye Strain
  - Minimizing Distractions
  - Managing Screen Time
11. Cultivating a Reading Routine John Deere 410 Backhoe Parts Manual
  - Setting Reading Goals John Deere 410 Backhoe Parts Manual
  - Carving Out Dedicated Reading Time
12. Sourcing Reliable Information of John Deere 410 Backhoe Parts Manual
  - Fact-Checking eBook Content of John Deere 410 Backhoe Parts Manual
  - Distinguishing Credible Sources
13. Promoting Lifelong Learning
  - Utilizing eBooks for Skill Development
  - Exploring Educational eBooks
14. Embracing eBook Trends
  - Integration of Multimedia Elements
  - Interactive and Gamified eBooks

## **John Deere 410 Backhoe Parts Manual Introduction**

In this digital age, the convenience of accessing information at our fingertips has become a necessity. Whether its research papers, eBooks, or user manuals, PDF files have become the preferred format for sharing and reading documents. However, the cost associated with purchasing PDF files can sometimes be a barrier for many individuals and organizations. Thankfully, there are numerous websites and platforms that allow users to download free PDF files legally. In this article, we will explore some of the best platforms to download free PDFs. One of the most popular platforms to download free PDF files is Project

Gutenberg. This online library offers over 60,000 free eBooks that are in the public domain. From classic literature to historical documents, Project Gutenberg provides a wide range of PDF files that can be downloaded and enjoyed on various devices. The website is user-friendly and allows users to search for specific titles or browse through different categories. Another reliable platform for downloading John Deere 410 Backhoe Parts Manual free PDF files is Open Library. With its vast collection of over 1 million eBooks, Open Library has something for every reader. The website offers a seamless experience by providing options to borrow or download PDF files. Users simply need to create a free account to access this treasure trove of knowledge. Open Library also allows users to contribute by uploading and sharing their own PDF files, making it a collaborative platform for book enthusiasts. For those interested in academic resources, there are websites dedicated to providing free PDFs of research papers and scientific articles. One such website is Academia.edu, which allows researchers and scholars to share their work with a global audience. Users can download PDF files of research papers, theses, and dissertations covering a wide range of subjects. Academia.edu also provides a platform for discussions and networking within the academic community. When it comes to downloading John Deere 410 Backhoe Parts Manual free PDF files of magazines, brochures, and catalogs, Issuu is a popular choice. This digital publishing platform hosts a vast collection of publications from around the world. Users can search for specific titles or explore various categories and genres. Issuu offers a seamless reading experience with its user-friendly interface and allows users to download PDF files for offline reading. Apart from dedicated platforms, search engines also play a crucial role in finding free PDF files. Google, for instance, has an advanced search feature that allows users to filter results by file type. By specifying the file type as "PDF," users can find websites that offer free PDF downloads on a specific topic. While downloading John Deere 410 Backhoe Parts Manual free PDF files is convenient, it's important to note that copyright laws must be respected. Always ensure that the PDF files you download are legally available for free. Many authors and publishers voluntarily provide free PDF versions of their work, but it's essential to be cautious and verify the authenticity of the source before downloading John Deere 410 Backhoe Parts Manual. In conclusion, the internet offers numerous platforms and websites that allow users to download free PDF files legally. Whether it's classic literature, research papers, or magazines, there is something for everyone. The platforms mentioned in this article, such as Project Gutenberg, Open Library, Academia.edu, and Issuu, provide access to a vast collection of PDF files. However, users should always be cautious and verify the legality of the source before downloading John Deere 410 Backhoe Parts Manual any PDF files. With these platforms, the world of PDF downloads is just a click away.

### **FAQs About John Deere 410 Backhoe Parts Manual Books**

How do I know which eBook platform is the best for me? Finding the best eBook platform depends on your reading

preferences and device compatibility. Research different platforms, read user reviews, and explore their features before making a choice. Are free eBooks of good quality? Yes, many reputable platforms offer high-quality free eBooks, including classics and public domain works. However, make sure to verify the source to ensure the eBook credibility. Can I read eBooks without an eReader? Absolutely! Most eBook platforms offer web-based readers or mobile apps that allow you to read eBooks on your computer, tablet, or smartphone. How do I avoid digital eye strain while reading eBooks? To prevent digital eye strain, take regular breaks, adjust the font size and background color, and ensure proper lighting while reading eBooks. What the advantage of interactive eBooks? Interactive eBooks incorporate multimedia elements, quizzes, and activities, enhancing the reader engagement and providing a more immersive learning experience. John Deere 410 Backhoe Parts Manual is one of the best book in our library for free trial. We provide copy of John Deere 410 Backhoe Parts Manual in digital format, so the resources that you find are reliable. There are also many Ebooks of related with John Deere 410 Backhoe Parts Manual. Where to download John Deere 410 Backhoe Parts Manual online for free? Are you looking for John Deere 410 Backhoe Parts Manual PDF? This is definitely going to save you time and cash in something you should think about.

### **Find John Deere 410 Backhoe Parts Manual :**

**fostex vm88 user guide**

**foundations for health promotion by naidoo 3rd edition**

**foundations in personal finance chapter 11 money and review**

**foxtel channel guide**

*framme loader reference guide*

~~four blind mice by james patterson~~

**fox ava rear shock manual**

fpsi study guide

franaise pop conte christophe

**foucaults pendulum guide**

foundations materials science engineering william

**foundations of marketing 6th edition**

fourth grade spiral pacing guide

**fpocr june 24**

**fortunes et infortunes des princes dorleacuteurs**



**John Deere 410 Backhoe Parts Manual :**

*afrika ganz anders abenteuer im congo copy* - Oct 04 2022

web congo michael crichton 2012 05 14 from the bestselling author of jurassic park timeline and sphere comes a gripping thriller about the shocking demise of eight american

**unbekanntes afrika kongo clip hd deutsch german** - Jul 01 2022

web sp ter kehrt er nach deutschland zur ck und entschlie t sich alsbald erneut nach afrika zu gehen im auftrag eines gro en deutschen anlagenbauers bernimmt er eine

**afrika ganz anders abenteuer im congo jürgen runge** - Nov 24 2021

web apr 5 2023 afrika ganz anders abenteuer im congo is available in our digital library an online access to it is set as public so you can get it instantly our book servers spans in

**afrika ganz anders abenteuer im congo pdf uniport edu** - Sep 03 2022

web abenteuer im congo by ingo anders andrea anders de bestseller die beliebtesten artikel in religion safari rustikal outback africa erlebnisreisen kongo filmkritik film tv

afrika ganz anders abenteuer im congo by ingo anders andrea - Jan 07 2023

web afrika ganz anders abenteuer im congo facebook

*afrika ganz anders abenteuer im congo by ingo anders andrea* - Apr 29 2022

web mar 24 2023 afrika ganz anders abenteuer im congo 3 6 downloaded from uniport edu ng on march 24 2023 by guest ingolstädter tagblatt 1894 meyers

**afrika ganz anders abenteuer im congo uniport edu** - Nov 05 2022

web afrika ganz anders abenteuer im congo downloaded from ftp adaircountymissouri com by guest jordyn decker afrika ganz anders wallstein verlag the challenge of

*afrika ganz anders abenteuer im congo copy* - May 31 2022

web afrika ganz anders abenteuer im congo by ingo anders andrea anders anne in kamerun fsj in afrika ein jahr in einer fast k eine zeitlose kunst heimatkunde was nimmt

**afrika ganz anders abenteuer im congo jürgen runge pdf** - Mar 09 2023

web nov 9 2017 aber im riesigen afrika findet man 54 länder voller surrealer naturwunder und ganz eigener kultureller erlebnisse für euch haben wir eine reihe unbekannterer

die besten abenteuerfilme afrika moviepilot de - Jan 27 2022

web entdecke die besten abenteuerfilme aus afrika kostenlos online verfügbar der mit dem wolf tanzt der fantastische mr fox

der werwolf von tarker mills

*afrika ganz anders abenteuer im congo facebook* - May 11 2023

web read reviews from the world s largest community for readers mit großer arroganz erklärte mundele du bist so farblos wie alle weißen wie ein leeres

**afrika ganz anders abenteuer im congo facebook** - Dec 06 2022

web jul 27 2023 afrika ganz anders abenteuer im congo 2 6 downloaded from uniport edu ng on july 27 2023 by guest b 1981 lubumbashi democratic republic of

**afrika ganz anders abenteuer im congo by ingo anders andrea** - Aug 02 2022

web nov 20 2014 der kongo ist der zweitlängste strom in afrika gemessen an seinen wassermassen ist er sogar der zweitgrößte und tiefste fluss der erde als rinnsal en

*afrika ganz anders abenteuer im congo 2023* - Jun 12 2023

web afrika ganz anders abenteuer im congo 49 likes spannende geschichte über das leben und arbeiten im congo mit zahlreichen fotos etc illustriert

die besten abenteuerfilme aus afrika kostenlos online verfügbar - Dec 26 2021

web afrika ganz anders abenteuer im congo afrika ganz anders abenteuer im congo 2 downloaded from old restorativejustice org on 2020 06 17 by guest roosevelt leading

die top 10 sehenswürdigkeiten in afrika 2023 mit fotos - Feb 25 2022

web 54 abenteuerfilm von john huston mit humphrey bogart und katharine hepburn african queen ist ein abenteuerfilm aus dem jahr 1951 der zur zeit des 1 weltkriegs im

*7 fantastische naturwunder afrikas national geographic* - Feb 08 2023

web jul 8 2023 afrika ganz anders abenteuer im congo de anders may 14th 2020 afrika ganz anders abenteuer im congo anders ingo anders ingo anders andrea isbn

afrika ganz anders abenteuer im congo taschenbuch - Jul 13 2023

web afrika ganz anders abenteuer im congo abenteuer im oak park feb 08 2022 den drei jungen eidechsen rocco henry und willi fehlt es in ihrem park eigentlich an nichts

**afrika ganz anders abenteuer im congo goodreads** - Apr 10 2023

web it will definitely ease you to see guide afrika ganz anders abenteuer im congo as you such as by searching the title publisher or authors of guide you truly want you can

**afrika ganz anders abenteuer im congo amazon de** - Aug 14 2023

web afrika ganz anders abenteuer im congo finden sie alle bücher von anders ingo bei der büchersuchmaschine eurobuch

com können sie antiquarische und neubücher

**afrika ganz anders abenteuer im congo uniport edu** - Oct 24 2021

**afrika ganz anders abenteuer im congo copy uniport edu** - Mar 29 2022

web 08 09 2023 top afrika sehenswürdigkeiten hier finden sie 12 002 984 bewertungen und fotos von reisenden über 50 308 sehenswürdigkeiten touren und ausflüge alle

**data analytics tutorial for beginners a step by step guide** - Dec 28 2021

web aug 29 2023 if you have a keen interest in data and how to derive useful information from data you can apply for the popular data analytics bootcamp offered by simplilearn from beginners to senior data analysts this data analytics tutorial will help you choose exactly which course you should start with

data analytics the ultimate guide to big data analytics for - Jul 15 2023

web data analytics the ultimate guide to big data analytics for business data mining techniques data collection and business intelligence concepts jones herbert amazon com tr kitap

**data analytics the ultimate guide to big data ana pdf pdf** - Sep 05 2022

web title data analytics the ultimate guide to big data ana pdf pdf networks kualumni org created date 9 6 2023 4 49 54 pm  
*data science the ultimate guide to data analytics data mining data* - Feb 27 2022

web jan 3 2020 data science the ultimate guide to data analytics data mining data warehousing data visualization regression analysis database querying big data for business and machine learning for beginners herbert jones bravex publications jan 3 2020 134 pages

*data analytics the ultimate beginner s guide to data analytics* - Mar 31 2022

web an understanding of the edge that business intelligence and data analytics plays in the real world today an introduction to the different types of data analytics what it means in the real world and how you can apply it in your life for better quality and more powerful results

data analytics the ultimate guide to big data ana copy lgscout - Jul 03 2022

web data analytics the ultimate guide to big data ana 3 3 ultimate guide to learn and master data analytics get your business intelligence right accelerate growth and close more sales leading companies must not only compete on faster roi within the shortest time but also face stiff competition in this digital frontier age with no boundaries but

**data analytics the ultimate beginner s guide amazon com tr** - Nov 07 2022

web data analytics the ultimate beginner s guide maxwell lee amazon com tr Çerez tercihlerinizi seçin alışveriş deneyiminizi geliştirmek hizmetlerimizi sunmak müşterilerin hizmetlerimizi nasıl kullandığını anlayarak iyileştirmeler yapabilmek ve

tanıtımları gösterebilmek için çerezler ve benzeri araçları kullanmaktayız

**data analytics the ultimate guide to big data analytics for** - Mar 11 2023

web here are just some of the topics that are discussed in the first part of this book overview of data analytics what is data analytics and big data analytics data analytics and business intelligence data analysis and data analytics data mining data collection types of data analytics the process the lifecycle of big data analytics behavioral

data analytics the ultimate guide to big data ana download - Oct 06 2022

web data analytics the ultimate guide to big data ana 3 3 and production of a machine learning project how adopting machine learning techniques will redefine the future of your erp crm system perfect for technical consultants software developers and solution architects machine learning with

*data analytics the ultimate guide to big data ana judith s* - Feb 10 2023

web data analytics the ultimate guide to big data ana right here we have countless ebook data analytics the ultimate guide to big data ana and collections to check out we additionally manage to pay for variant types and furthermore type of the books to browse

the ultimate guide to big data for businesses techtarget - Jun 02 2022

web feb 23 2022 big data creates increased opportunities for machine learning predictive analytics data mining streaming analytics text mining and other data science and advanced analytics disciplines using those disciplines big data analytics applications help businesses better understand customers identify operational issues detect

ultimate guide to data analytics simplified 101 - Aug 04 2022

web dec 29 2022 this data analytics guide provides you with a comprehensive overview of data analytics it also explains the types processes and tools involved while performing data analysis lastly our data analytics guide will brief you on application and career insights to grow in the field of data analytics

**data analytics the ultimate guide to big data analytics for** - Aug 16 2023

web sep 19 2018 data analytics the ultimate guide to big data analytics for business data mining techniques data collection and business intelligence concepts jones herbert on amazon com free shipping on qualifying offers

*data analytics the ultimate guide to big data ana copy whm* - Jan 29 2022

web we provide data analytics the ultimate guide to big data ana and numerous books collections from fictions to scientific research in any way in the midst of them is this data analytics the ultimate guide to big data ana that can be your partner data analytics the ultimate guide to big data ana 2021 03 29 patrick perkins

**data analytics the ultimate guide to big data analytics for** - Jan 09 2023

web oct 22 2018 if you want to learn about data analytics and data mining then keep reading this is a collection of two

comprehensive books in one here are just some of the topics that are discussed in the first part of this audiobook overview of data analytics what data analytics is and big data analytics

**data analytics the ultimate guide to big data analytics for** - Apr 12 2023

web data analytics the ultimate guide to big data analytics for business data mining techniques data collection and business intelligence concepts audible audiobook unabridged herbert jones author publisher sam slydell narrator dryw mcarthur narrator 0 more

**what is big data analytics microsoft azure** - May 01 2022

web big data analytics refers to the methods tools and applications used to collect process and derive insights from varied high volume high velocity data sets these data sets may come from a variety of sources such as web mobile email social media and networked smart devices they often feature data that is generated at a high speed

*the ultimate guide to data analytics comptia* - Dec 08 2022

web the ultimate guide to data analytics download comptia s free ultimate guide to data analytics and discover everything you need to know to get started on your data career today download the guide

*data analytics the ultimate guide to big data analytic* - Jun 14 2023

web sep 14 2018 data analytics the ultimate guide to big data analytics for business data mining techniques data collection and business intelligence concepts by herbert jones goodreads jump to ratings and reviews

**data analytics the ultimate guide to big data analytics for** - May 13 2023

web data analytics the ultimate guide to big data analytics for business data mining techniques data collection and business intelligence concepts by jones herbert isbn 10 1647483298 isbn 13 9781647483296 bravex publications 2020 hardcover

*schaum s outline of operations research amazon com* - Jun 16 2023

web confusing textbooks missed lectures not enough time fortunately for you there s schaum s outlines more than 40 million students have trusted schaum s to help them

schaum s outline operations research pdf scribd - Aug 06 2022

web dec 23 2022 schaum s outline of theory and problems of operations management by monks joseph g publication date 1996 topics production management industrial

**schaum s outline of operations research** - Mar 01 2022

schaum s outline of operations research schaum s - Jul 17 2023

web this schaum s outline gives you practice problems with full explanations that reinforce knowledge coverage of the most up to date developments in your course field in depth

*schaum s outline of operations research google books* - Sep 19 2023

web jul 22 1997 practice problems with full explanations that reinforce knowledge coverage of the most up to date developments in your course field in depth review of practices and

*schaum s outline of operations research schaum s outlines* - Nov 09 2022

web jul 22 1997 engineering transportation engineering buy now with 1 click ebook features highlight take notes and search in the book follow the authors richard

**schaum s outline of theory and problems of operations** - Feb 12 2023

web sep 16 1997 buy schaum s outline of operations research by richard bronson govindasami naadimuthu from waterstones today click and collect from your local

*schaum s outline of theory and problems of operations research* - Nov 28 2021

*schaum s outline operations research pdf document* - Dec 10 2022

web schaum s outline operations research free ebook download as pdf file pdf or read book online for free

*schaum s outline of operations research paperback* - Oct 08 2022

web schaum s outline of operations research author richard bronson govindasami naadimuthu 2977 downloads 7577 views 28mb size report this content was

**schaum s outline of operations research barnes noble** - Jan 11 2023

web 18 99 publisher description confusing textbooks missed lectures not enough time fortunately for you there s schaum s outlines more than 40 million students have

*schaum s outline of operations research apple books* - Sep 07 2022

web oct 4 2023 download schaum s outline of operations research download book schaum s outline of operations research download ebook

*schaum s outline of operations research scribd* - Mar 13 2023

web schaum s is the key to faster learning and higher grades in every subject each outline presents all the essential course information in an easy to follow topic by topic format

**schaum s outline of theory and problems of** - Aug 18 2023

web 3 92 62 ratings0 reviews confusing textbooks missed lectures not enough time fortunately for you there s schaum s outlines more than 40 million students have

**schaum s outline of operating systems archive org** - Dec 30 2021

[schaum s outline of operations research goodreads](#) - May 15 2023

web jul 1 1997 this schaum s outline gives you practice problems with full explanations that reinforce knowledge coverage of the most up to date developments in your course field

[schaum s outline of theory and problems of operations management](#) - Apr 02 2022

**schaum s outline of operations research pdf free download** - Jun 04 2022

web ames research center software internet arcade console living room featured all software this just in schaum s outline of operating systems by harris j archer

**schaum s outline of operations research schaum s outlines** - Jul 05 2022

web download pdf schaum s outline of operations research pdf 7ojg194k4jt0 this book makes for a very readable self contained introduction to the subject through clear

[download schaum s outline of operations research pdf](#) - Jan 31 2022

**schaum s outline of theory and problems of** - Apr 14 2023

web dec 4 2014 schaum s outline operations research date post 04 dec 2014 category documents upload abhinav anand view 3 512 times download 1 624

*schaum s outline of operations research issuu* - May 03 2022

web dec 8 2022 schaum s outline of theory and problems of operations research by richard bronson 1982 mcgraw hill edition in english