

JCB 9802/2320 A1-4-2 SHOVEL, 2.3 CU.M., Z BAR

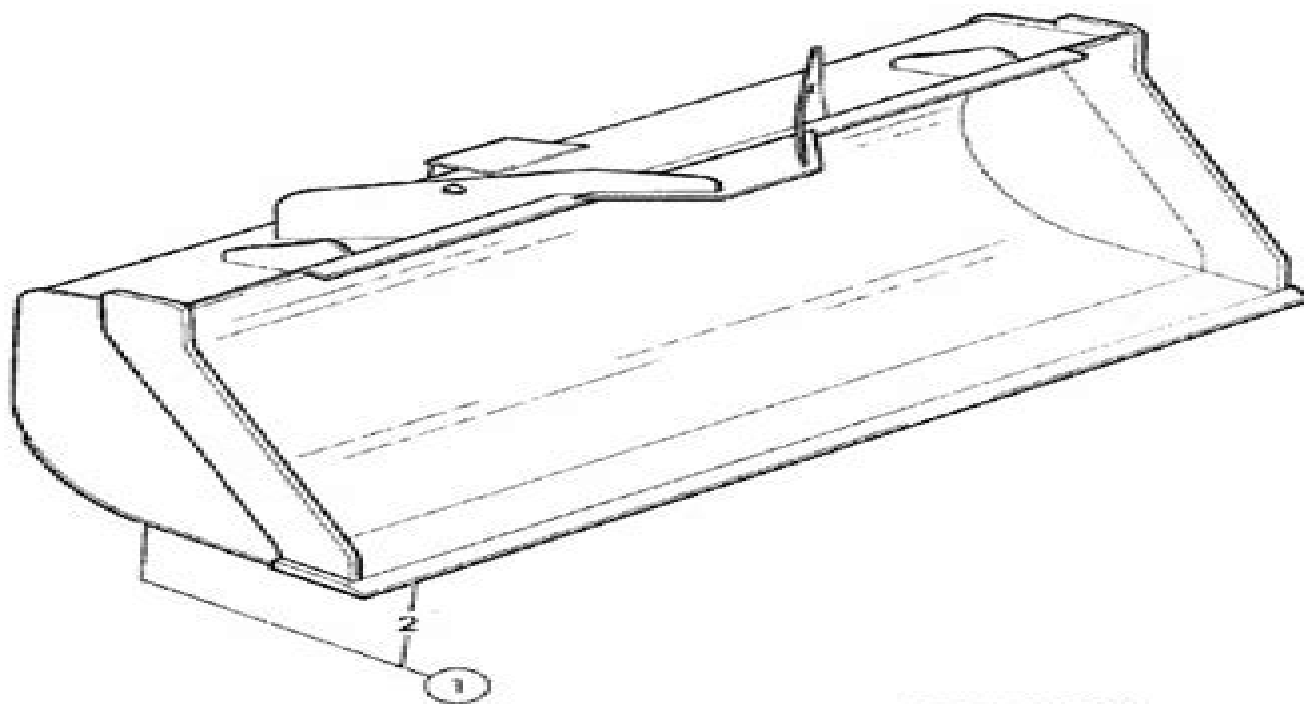

220900

Item	Part #	Change No	Description	Usage Code	QTY
1	510/84300	Superseded	Shovel 2.3 cu.m., Z Bar	A	1
1	510/93200	Superseded	Shovel 2.3 cu.m., Z Bar		1
1	510/94000		Shovel 2.3cu.m./3.0cu yd.		1

Jcb 436 Ht Manual

R Barnett



Jcb 436 Ht Manual:

This is likewise one of the factors by obtaining the soft documents of this **Jcb 436 Ht Manual** by online. You might not require more grow old to spend to go to the ebook creation as with ease as search for them. In some cases, you likewise attain not discover the notice Jcb 436 Ht Manual that you are looking for. It will categorically squander the time.

However below, afterward you visit this web page, it will be thus utterly easy to get as without difficulty as download guide Jcb 436 Ht Manual

It will not allow many period as we run by before. You can complete it even if accomplishment something else at home and even in your workplace. hence easy! So, are you question? Just exercise just what we pay for below as skillfully as review **Jcb 436 Ht Manual** what you bearing in mind to read!

<https://staging.conocer.cide.edu/About/Resources/default.aspx/Hitachi%20Vcr%20Owners%20Manual.pdf>

Table of Contents Jcb 436 Ht Manual

1. Understanding the eBook Jcb 436 Ht Manual
 - The Rise of Digital Reading Jcb 436 Ht Manual
 - Advantages of eBooks Over Traditional Books
2. Identifying Jcb 436 Ht Manual
 - Exploring Different Genres
 - Considering Fiction vs. Non-Fiction
 - Determining Your Reading Goals
3. Choosing the Right eBook Platform
 - Popular eBook Platforms
 - Features to Look for in an Jcb 436 Ht Manual
 - User-Friendly Interface
4. Exploring eBook Recommendations from Jcb 436 Ht Manual
 - Personalized Recommendations

- Jcb 436 Ht Manual User Reviews and Ratings
- Jcb 436 Ht Manual and Bestseller Lists
- 5. Accessing Jcb 436 Ht Manual Free and Paid eBooks
 - Jcb 436 Ht Manual Public Domain eBooks
 - Jcb 436 Ht Manual eBook Subscription Services
 - Jcb 436 Ht Manual Budget-Friendly Options
- 6. Navigating Jcb 436 Ht Manual eBook Formats
 - ePub, PDF, MOBI, and More
 - Jcb 436 Ht Manual Compatibility with Devices
 - Jcb 436 Ht Manual Enhanced eBook Features
- 7. Enhancing Your Reading Experience
 - Adjustable Fonts and Text Sizes of Jcb 436 Ht Manual
 - Highlighting and Note-Taking Jcb 436 Ht Manual
 - Interactive Elements Jcb 436 Ht Manual
- 8. Staying Engaged with Jcb 436 Ht Manual
 - Joining Online Reading Communities
 - Participating in Virtual Book Clubs
 - Following Authors and Publishers Jcb 436 Ht Manual
- 9. Balancing eBooks and Physical Books Jcb 436 Ht Manual
 - Benefits of a Digital Library
 - Creating a Diverse Reading Collection Jcb 436 Ht Manual
- 10. Overcoming Reading Challenges
 - Dealing with Digital Eye Strain
 - Minimizing Distractions
 - Managing Screen Time
- 11. Cultivating a Reading Routine Jcb 436 Ht Manual
 - Setting Reading Goals Jcb 436 Ht Manual
 - Carving Out Dedicated Reading Time
- 12. Sourcing Reliable Information of Jcb 436 Ht Manual
 - Fact-Checking eBook Content of Jcb 436 Ht Manual

- Distinguishing Credible Sources
- 13. Promoting Lifelong Learning
 - Utilizing eBooks for Skill Development
 - Exploring Educational eBooks
- 14. Embracing eBook Trends
 - Integration of Multimedia Elements
 - Interactive and Gamified eBooks

Jcb 436 Ht Manual Introduction

In this digital age, the convenience of accessing information at our fingertips has become a necessity. Whether its research papers, eBooks, or user manuals, PDF files have become the preferred format for sharing and reading documents. However, the cost associated with purchasing PDF files can sometimes be a barrier for many individuals and organizations. Thankfully, there are numerous websites and platforms that allow users to download free PDF files legally. In this article, we will explore some of the best platforms to download free PDFs. One of the most popular platforms to download free PDF files is Project Gutenberg. This online library offers over 60,000 free eBooks that are in the public domain. From classic literature to historical documents, Project Gutenberg provides a wide range of PDF files that can be downloaded and enjoyed on various devices. The website is user-friendly and allows users to search for specific titles or browse through different categories. Another reliable platform for downloading Jcb 436 Ht Manual free PDF files is Open Library. With its vast collection of over 1 million eBooks, Open Library has something for every reader. The website offers a seamless experience by providing options to borrow or download PDF files. Users simply need to create a free account to access this treasure trove of knowledge. Open Library also allows users to contribute by uploading and sharing their own PDF files, making it a collaborative platform for book enthusiasts. For those interested in academic resources, there are websites dedicated to providing free PDFs of research papers and scientific articles. One such website is Academia.edu, which allows researchers and scholars to share their work with a global audience. Users can download PDF files of research papers, theses, and dissertations covering a wide range of subjects. Academia.edu also provides a platform for discussions and networking within the academic community. When it comes to downloading Jcb 436 Ht Manual free PDF files of magazines, brochures, and catalogs, Issuu is a popular choice. This digital publishing platform hosts a vast collection of publications from around the world. Users can search for specific titles or explore various categories and genres. Issuu offers a seamless reading experience with its user-friendly interface and allows users to download PDF files for offline reading. Apart from dedicated platforms, search engines also play a crucial role in finding free PDF files. Google, for instance, has an advanced search feature that allows users to

filter results by file type. By specifying the file type as "PDF," users can find websites that offer free PDF downloads on a specific topic. While downloading Jcb 436 Ht Manual free PDF files is convenient, it's important to note that copyright laws must be respected. Always ensure that the PDF files you download are legally available for free. Many authors and publishers voluntarily provide free PDF versions of their work, but it's essential to be cautious and verify the authenticity of the source before downloading Jcb 436 Ht Manual. In conclusion, the internet offers numerous platforms and websites that allow users to download free PDF files legally. Whether it's classic literature, research papers, or magazines, there is something for everyone. The platforms mentioned in this article, such as Project Gutenberg, Open Library, Academia.edu, and Issuu, provide access to a vast collection of PDF files. However, users should always be cautious and verify the legality of the source before downloading Jcb 436 Ht Manual any PDF files. With these platforms, the world of PDF downloads is just a click away.

FAQs About Jcb 436 Ht Manual Books

How do I know which eBook platform is the best for me? Finding the best eBook platform depends on your reading preferences and device compatibility. Research different platforms, read user reviews, and explore their features before making a choice. Are free eBooks of good quality? Yes, many reputable platforms offer high-quality free eBooks, including classics and public domain works. However, make sure to verify the source to ensure the eBook's credibility. Can I read eBooks without an eReader? Absolutely! Most eBook platforms offer web-based readers or mobile apps that allow you to read eBooks on your computer, tablet, or smartphone. How do I avoid digital eye strain while reading eBooks? To prevent digital eye strain, take regular breaks, adjust the font size and background color, and ensure proper lighting while reading eBooks. What's the advantage of interactive eBooks? Interactive eBooks incorporate multimedia elements, quizzes, and activities, enhancing the reader engagement and providing a more immersive learning experience. Jcb 436 Ht Manual is one of the best books in our library for free trial. We provide a copy of Jcb 436 Ht Manual in digital format, so the resources that you find are reliable. There are also many eBooks related to Jcb 436 Ht Manual. Where to download Jcb 436 Ht Manual online for free? Are you looking for Jcb 436 Ht Manual PDF? This is definitely going to save you time and cash in something you should think about. If you're trying to find them, search around for online. Without a doubt, there are numerous of these available and many of them have the freedom. However, without a doubt, you receive whatever you purchase. An alternate way to get ideas is always to check another Jcb 436 Ht Manual. This method for seeing exactly what may be included and adopting these ideas to your book. This site will almost certainly help you save time and effort, money and stress. If you are looking for free books, then you really should consider finding to assist you try this. Several of Jcb 436 Ht Manual are for sale to free while some are payable. If you aren't sure if the books you would like to download work with for usage along with your computer, it is

possible to download free trials. The free guides make it easy for someone to free access online library for download books to your device. You can get free download on free trial for lots of books categories. Our library is the biggest of these that have literally hundreds of thousands of different products categories represented. You will also see that there are specific sites catered to different product types or categories, brands or niches related with Jcb 436 Ht Manual. So depending on what exactly you are searching, you will be able to choose e books to suit your own need. Need to access completely for Campbell Biology Seventh Edition book? Access Ebook without any digging. And by having access to our ebook online or by storing it on your computer, you have convenient answers with Jcb 436 Ht Manual To get started finding Jcb 436 Ht Manual, you are right to find our website which has a comprehensive collection of books online. Our library is the biggest of these that have literally hundreds of thousands of different products represented. You will also see that there are specific sites catered to different categories or niches related with Jcb 436 Ht Manual So depending on what exactly you are searching, you will be able to choose ebook to suit your own need. Thank you for reading Jcb 436 Ht Manual. Maybe you have knowledge that, people have search numerous times for their favorite readings like this Jcb 436 Ht Manual, but end up in harmful downloads. Rather than reading a good book with a cup of coffee in the afternoon, instead they juggled with some harmful bugs inside their laptop. Jcb 436 Ht Manual is available in our book collection an online access to it is set as public so you can download it instantly. Our digital library spans in multiple locations, allowing you to get the most less latency time to download any of our books like this one. Merely said, Jcb 436 Ht Manual is universally compatible with any devices to read.

Find Jcb 436 Ht Manual :

hitachi vcr owners manual

hitachi 32pd5000 42pd5000 plasma display repair manual

hitachi g10sd1 manual

hkde eng sample paper answer

hitachi hdb73 manual

hm storytown grade 3 teacher guide

~~hobbes on the citizen rar~~

hkcee human biology 2001 i q2a

hitachi pa0117 53sbx59b projection color television repair manual

~~hitachi ex200 1 excavator service manual~~

hitachi seiki ht20sii manual

hitachi ds18dl 1 2 cordless drill power tools owners manual

hitachi ex200 owners manual*hogg 8th edition odd solutions manual***hm manual 14295a****Jcb 436 Ht Manual :**

7th GRADE MATH COMMON CORE REVIEW - TPT This download consists of 9 “crash course” reviews with explanations and examples. Every "crash course" is followed by a practice assessment comprised of items ... Math Incoming 7th Grade Summer Break Packet Math Incoming 7th Grade Summer Break Packet. Due Date: August 19th, Monday. Expectations. • Please complete 2 assignments per week. final review packet math 7r FINAL REVIEW PACKET MATH 7R. This Packet is a review of we covered this year in 7th grade mathematics. • Unit 1: Rational Numbers. • Unit 2: Expressions ... Grade 7 Advanced Math Review Packet.pdf Attached to this letter is a packet of materials to help you supplement your child's education while away from the formal school environment. Please feel free ... 7th Grade Math All-Year Review Packet: Study Guide & Test ... Aligned to Common Core/Georgia Standards of Excellence.This review packet contains six sections, each beginning with a study guide followed by test ... 2021 Summer Math Packet: 7th to 8th Grade This summer, we encourage you to continue to practice your mathematics at home. Practicing math skills over the summer can keep the brain's pathways for ... 7th Grade Math Full-Year Review Packet - Teach Simple 7th Grade Math Full-Year Review Packet based on Common Core State Standards. Each section begins with a summary of all concepts in the unit followed by ... 7th Grade - Sort By Grade Create-A-Review. Create-A ... Math worksheets for kids. Created by educators, teachers and peer reviewed. Terms of Use FAQS Contact © 2012-2023, Common Core ... 7th Grade Common Core Math Worksheets: FREE & Printable Jun 16, 2020 — Need FREE printable 7th Grade Common Core math questions and exercises to help your students review and practice Common Core mathematics ... 7th Grade Math Review Packet - YouTube This is a year review of 7th grade math concepts. The packet is perfect for the beginning of 8th grade math. Students can refresh their ... Hans Kleiber Studio - Sheridan, Wyoming Travel and Tourism Hans Kleiber Studio - Sheridan, Wyoming Travel and Tourism Hans Kleiber: Artist of the Bighorn Mountains Book details · Print length. 152 pages · Language. English · Publisher. Caxton Pr · Publication date. January 1, 1975 · Dimensions. 9.25 x 1 x 13.75 inches. Hans Kleiber: Artist of the Bighorn Mountains Hans Kleiber: Artist of the Bighorn Mountains ... Extensive text about the artist and his work; Beautiful illustrations. Price: \$29.97. Hans Kleiber: Artist of the Bighorn Mountains Hans Kleiber: Artist of the Bighorn Mountains, by Emmie D. Mygatt and Roberta Carkeek Cheney; Caxton Printers. Hans Kleiber: Artist of the Bighorn Mountains Illustrated through-out in black & white and color. Oblong, 11" x 8 1/2" hardcover is in VG+ condition in a near fine dust jacket. The book has dust staining to ... Hans Kleiber - Wyoming Game and Fish Department In 1906 , Kleiber moved west and joined the McShane Timber company, based in the

Bighorn Mountains, as he was too young for a Civil Service position. In 1908, ... Archives On The Air 236: Artist Of The Bighorns Dec 12, 2020 — German-born artist Hans Kleiber immigrated to the U.S. as a teenager in 1900. He developed what he called "an abiding love for whatever the ... Hans Kleiber: Artist of the Big Horn Mountains-First Edition ... Hans Kleiber: Artist of the Big Horn Mountains-First Edition/DJ-1975-Illustrated ; ISBN. 9780870042478 ; Accurate description. 5.0 ; Reasonable shipping cost. 5.0. Perspective: Hans Kleiber [1887-1967] Beyond etching, Kleiber exercised no restraint with both palette and design as a nature painter. He also studied the human figure. Although his wife, Missy, ... Pitch Anything Summary of Key Ideas and Review | Oren Klaff Pitch Anything Summary of Key Ideas and Review | Oren Klaff Oren Klaff's Complete Pitch Anything Summary in 12 minutes May 9, 2019 — Every pitch should tell a story. Eliminate the neediness. The brain is wired to do things to achieve status, not money. The mind continually ... Pitch Anything Summary Aug 7, 2016 — This Pitch Anything summary breaks down the science of selling on your 3 brain levels and shows you how to make yourself the prize & trigger ... Pitch Anything by Oren Klaff: Book Overview Jul 8, 2021 — In his book Pitch Anything, Oren Klaff teaches you how to appeal to your target's croc brain by understanding what makes it tick and working ... Pitch Anything Summary and Review | Oren Klaff Apr 8, 2021 — Oren Klaff outlines that a great pitch is never about the procedure. Instead, it is about getting and keeping the attention of the people you ... Pitch Anything Summary, Review PDF In Review: Pitch Anything Book Summary. The key message in this book is: In any social encounter where you aim to be persuasive, it is vital that you seize ... Pitch Anything: Summary & Framework + PDF Pitch Anything (2011) teaches readers how to raise money and sell their ideas to investors and venture capitalists by mastering power dynamics, ... Pitch Anything: Summary Review & Takeaways The concept of "prizing": The book introduces the concept of offering rewards or incentives to create a sense of value and scarcity, making the pitch more ... Pitch Anything: An Innovative Method for Delivering A Pitch When it comes to delivering a pitch, Oren Klaff has unparalleled credentials. Over the past 13 years, he has used his one-of-a-kind method to raise more ...