

Homelite®

HLT26CD

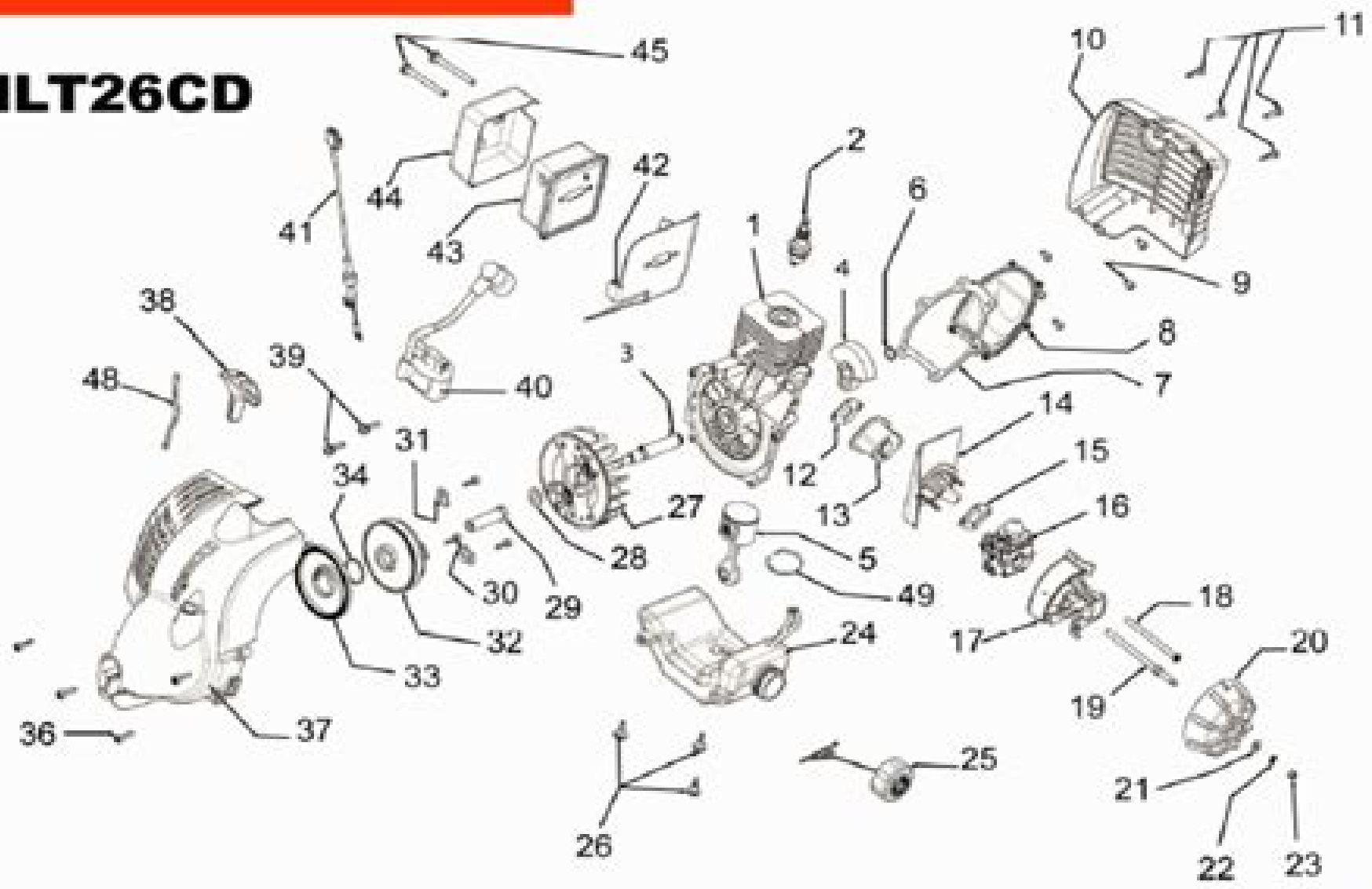

Manual For Hlt26cd Manuel

Michael Brown



Manual For Hlt26cd Manuel:

The Enigmatic Realm of **Manual For Hlt26cd Manuel**: Unleashing the Language is Inner Magic

In a fast-paced digital era where connections and knowledge intertwine, the enigmatic realm of language reveals its inherent magic. Its capacity to stir emotions, ignite contemplation, and catalyze profound transformations is nothing short of extraordinary. Within the captivating pages of **Manual For Hlt26cd Manuel** a literary masterpiece penned with a renowned author, readers embark on a transformative journey, unlocking the secrets and untapped potential embedded within each word. In this evaluation, we shall explore the book's core themes, assess its distinct writing style, and delve into its lasting affect the hearts and minds of those that partake in its reading experience.

https://staging.conocer.cide.edu/About/book-search/index.jsp/Ford_Truck_Harley_Davidson_Edition.pdf

Table of Contents Manual For Hlt26cd Manuel

1. Understanding the eBook Manual For Hlt26cd Manuel
 - The Rise of Digital Reading Manual For Hlt26cd Manuel
 - Advantages of eBooks Over Traditional Books
2. Identifying Manual For Hlt26cd Manuel
 - Exploring Different Genres
 - Considering Fiction vs. Non-Fiction
 - Determining Your Reading Goals
3. Choosing the Right eBook Platform
 - Popular eBook Platforms
 - Features to Look for in an Manual For Hlt26cd Manuel
 - User-Friendly Interface
4. Exploring eBook Recommendations from Manual For Hlt26cd Manuel
 - Personalized Recommendations
 - Manual For Hlt26cd Manuel User Reviews and Ratings
 - Manual For Hlt26cd Manuel and Bestseller Lists

5. Accessing Manual For Hlt26cd Manuel Free and Paid eBooks
 - Manual For Hlt26cd Manuel Public Domain eBooks
 - Manual For Hlt26cd Manuel eBook Subscription Services
 - Manual For Hlt26cd Manuel Budget-Friendly Options
6. Navigating Manual For Hlt26cd Manuel eBook Formats
 - ePub, PDF, MOBI, and More
 - Manual For Hlt26cd Manuel Compatibility with Devices
 - Manual For Hlt26cd Manuel Enhanced eBook Features
7. Enhancing Your Reading Experience
 - Adjustable Fonts and Text Sizes of Manual For Hlt26cd Manuel
 - Highlighting and Note-Taking Manual For Hlt26cd Manuel
 - Interactive Elements Manual For Hlt26cd Manuel
8. Staying Engaged with Manual For Hlt26cd Manuel
 - Joining Online Reading Communities
 - Participating in Virtual Book Clubs
 - Following Authors and Publishers Manual For Hlt26cd Manuel
9. Balancing eBooks and Physical Books Manual For Hlt26cd Manuel
 - Benefits of a Digital Library
 - Creating a Diverse Reading Collection Manual For Hlt26cd Manuel
10. Overcoming Reading Challenges
 - Dealing with Digital Eye Strain
 - Minimizing Distractions
 - Managing Screen Time
11. Cultivating a Reading Routine Manual For Hlt26cd Manuel
 - Setting Reading Goals Manual For Hlt26cd Manuel
 - Carving Out Dedicated Reading Time
12. Sourcing Reliable Information of Manual For Hlt26cd Manuel
 - Fact-Checking eBook Content of Manual For Hlt26cd Manuel
 - Distinguishing Credible Sources
13. Promoting Lifelong Learning

- Utilizing eBooks for Skill Development
 - Exploring Educational eBooks
14. Embracing eBook Trends
- Integration of Multimedia Elements
 - Interactive and Gamified eBooks

Manual For Hlt26cd Manuel Introduction

Free PDF Books and Manuals for Download: Unlocking Knowledge at Your Fingertips In today's fast-paced digital age, obtaining valuable knowledge has become easier than ever. Thanks to the internet, a vast array of books and manuals are now available for free download in PDF format. Whether you are a student, professional, or simply an avid reader, this treasure trove of downloadable resources offers a wealth of information, conveniently accessible anytime, anywhere. The advent of online libraries and platforms dedicated to sharing knowledge has revolutionized the way we consume information. No longer confined to physical libraries or bookstores, readers can now access an extensive collection of digital books and manuals with just a few clicks. These resources, available in PDF, Microsoft Word, and PowerPoint formats, cater to a wide range of interests, including literature, technology, science, history, and much more. One notable platform where you can explore and download free Manual For Hlt26cd Manuel PDF books and manuals is the internet's largest free library. Hosted online, this catalog compiles a vast assortment of documents, making it a veritable goldmine of knowledge. With its easy-to-use website interface and customizable PDF generator, this platform offers a user-friendly experience, allowing individuals to effortlessly navigate and access the information they seek. The availability of free PDF books and manuals on this platform demonstrates its commitment to democratizing education and empowering individuals with the tools needed to succeed in their chosen fields. It allows anyone, regardless of their background or financial limitations, to expand their horizons and gain insights from experts in various disciplines. One of the most significant advantages of downloading PDF books and manuals lies in their portability. Unlike physical copies, digital books can be stored and carried on a single device, such as a tablet or smartphone, saving valuable space and weight. This convenience makes it possible for readers to have their entire library at their fingertips, whether they are commuting, traveling, or simply enjoying a lazy afternoon at home. Additionally, digital files are easily searchable, enabling readers to locate specific information within seconds. With a few keystrokes, users can search for keywords, topics, or phrases, making research and finding relevant information a breeze. This efficiency saves time and effort, streamlining the learning process and allowing individuals to focus on extracting the information they need. Furthermore, the availability of free PDF books and manuals fosters a culture of continuous learning. By removing financial barriers, more people can access educational resources and pursue lifelong learning, contributing to personal

growth and professional development. This democratization of knowledge promotes intellectual curiosity and empowers individuals to become lifelong learners, promoting progress and innovation in various fields. It is worth noting that while accessing free Manual For Hlt26cd Manuel PDF books and manuals is convenient and cost-effective, it is vital to respect copyright laws and intellectual property rights. Platforms offering free downloads often operate within legal boundaries, ensuring that the materials they provide are either in the public domain or authorized for distribution. By adhering to copyright laws, users can enjoy the benefits of free access to knowledge while supporting the authors and publishers who make these resources available. In conclusion, the availability of Manual For Hlt26cd Manuel free PDF books and manuals for download has revolutionized the way we access and consume knowledge. With just a few clicks, individuals can explore a vast collection of resources across different disciplines, all free of charge. This accessibility empowers individuals to become lifelong learners, contributing to personal growth, professional development, and the advancement of society as a whole. So why not unlock a world of knowledge today? Start exploring the vast sea of free PDF books and manuals waiting to be discovered right at your fingertips.

FAQs About Manual For Hlt26cd Manuel Books

What is a Manual For Hlt26cd Manuel PDF? A PDF (Portable Document Format) is a file format developed by Adobe that preserves the layout and formatting of a document, regardless of the software, hardware, or operating system used to view or print it. **How do I create a Manual For Hlt26cd Manuel PDF?** There are several ways to create a PDF: Use software like Adobe Acrobat, Microsoft Word, or Google Docs, which often have built-in PDF creation tools. Print to PDF: Many applications and operating systems have a "Print to PDF" option that allows you to save a document as a PDF file instead of printing it on paper. Online converters: There are various online tools that can convert different file types to PDF. **How do I edit a Manual For Hlt26cd Manuel PDF?** Editing a PDF can be done with software like Adobe Acrobat, which allows direct editing of text, images, and other elements within the PDF. Some free tools, like PDFescape or Smallpdf, also offer basic editing capabilities. **How do I convert a Manual For Hlt26cd Manuel PDF to another file format?** There are multiple ways to convert a PDF to another format: Use online converters like Smallpdf, Zamzar, or Adobe Acrobats export feature to convert PDFs to formats like Word, Excel, JPEG, etc. Software like Adobe Acrobat, Microsoft Word, or other PDF editors may have options to export or save PDFs in different formats. **How do I password-protect a Manual For Hlt26cd Manuel PDF?** Most PDF editing software allows you to add password protection. In Adobe Acrobat, for instance, you can go to "File" -> "Properties" -> "Security" to set a password to restrict access or editing capabilities. Are there any free alternatives to Adobe Acrobat for working with PDFs? Yes, there are many free alternatives for working with PDFs, such as:

LibreOffice: Offers PDF editing features. PDFsam: Allows splitting, merging, and editing PDFs. Foxit Reader: Provides basic PDF viewing and editing capabilities. How do I compress a PDF file? You can use online tools like Smallpdf, ILovePDF, or desktop software like Adobe Acrobat to compress PDF files without significant quality loss. Compression reduces the file size, making it easier to share and download. Can I fill out forms in a PDF file? Yes, most PDF viewers/editors like Adobe Acrobat, Preview (on Mac), or various online tools allow you to fill out forms in PDF files by selecting text fields and entering information. Are there any restrictions when working with PDFs? Some PDFs might have restrictions set by their creator, such as password protection, editing restrictions, or print restrictions. Breaking these restrictions might require specific software or tools, which may or may not be legal depending on the circumstances and local laws.

Find Manual For Hlt26cd Manuel :

~~ford truck harley davidson edition~~

~~ford shift lock system wiring~~

~~forms of value and valuation theory and application~~

~~ford transit mk6 haynes manual~~

fort carson holiday calendar 2014

~~formula guide for light fixtures~~

~~form past papers swaziland~~

~~forgotten promises the promises series book english edition~~

~~ford sierra service and repair manual~~

~~ford tourneo connect technic manual~~

~~ford windstar repair guide~~

~~ford system wiring diagram~~

~~forde ferrier comprehension~~

~~ford territory manual torrent haynes~~

~~forever viper english edition~~

Manual For Hlt26cd Manuel :

elmo s countdown to christmas sesame street lift - Oct 09 2023

web sep 13 2016 this holiday lift the flap board book is the perfect gift for sesame street fans girls and boys ages 2 to 5 will

have great fun finding more than 30 flaps to lift in

elmo s countdown to christmas sesame street lift the flap - Jun 05 2023

web elmo s countdown to christmas sesame street lift the flap kleinberg naomi amazon com tr

[elmo s countdown to christmas sesame street penguin](#) - Jul 06 2023

web this holiday lift the flap board book is the perfect gift for sesame street fans girls and boys ages 2 to 5 will have great fun finding more than 30 flaps to lift in this sturdy board

elmo s countdown to christmas 2016 book muppet wiki - Apr 03 2023

web elmo s countdown to christmas is a 2016 christmas lift the flap book serving a similar function to advent calendars the book encourages kids to lift over thirty flaps as the

elmo s countdown to christmas sesame street board book - Feb 01 2023

web sep 13 2016 overview count down to christmas with some help from elmo this holiday lift the flap board book is the perfect gift for sesame street fans girls and boys

sesame street elmo s christmas countdown 2008 youtube - Dec 19 2021

web dec 24 2019 52k views 3 years ago countdown to christmas with your favourite characters from sesame street dance and sing with elmo cookie monster abby

elmo s christmas countdown sesame street guide - Jul 26 2022

web download elmo 039 s countdown to christmas sesame street lift the flap board book lift the flap september 13 2016 pdf full count down to christmas

elmo s christmas countdown youtube - Aug 07 2023

web nov 5 2020 learn more provided to youtube by sesame street storytime elmo s christmas countdown sesame street storytime elmo s christmas countdown 2020 sesame workshop under

[sesame street elmo s christmas countdown streaming](#) - Jan 20 2022

web for themdccchannel407 copyright disclaimer under section 107 of the copyright act 1976 allowance is made for fair use for purposes such as criticism com

elmo s christmas countdown muppet wiki fandom - Nov 29 2022

web sesame street elmo s christmas countdown 2007 44 minutes 4 0 star 86 reviews 80 tomatometer tv y rating family home eligible info 6 99 buy sd 1 99 rent sd

elmo s countdown to christmas sesame street lift t roger - Oct 17 2021

sesame street elmo s christmas countdown youtube - Mar 22 2022

web dec 14 2022 christmas time is here join elmo and friends as they sing some of his favorite songs for the holidays
subscribe to the sesame street channel here ww

[elmo s christmas countdown wikipedia](#) - Aug 27 2022

web episode 4427 release date 2008 produced by genius entertainment elmo s christmas countdown is a christmas special
episode first it was aired on 23 december 2007 on

download elmo s countdown to christmas sesame street - Jun 24 2022

web 6 1 44min 2007 g there s a miracle on sesame street elmo abby cadabby and their new friend stiller the elf are going to
count down to christmas with the christmas

elmo s christmas countdown 2007 youtube - Sep 27 2022

web in elmo s christmas countdown stiller the elf ben stiller is telling stan the snowball how christmas was almost ruined he
recounts how he visited sesame street because

[prime video elmo s christmas countdown](#) - May 24 2022

web there s a miracle on sesame street in this special holiday tale elmo abby cadabby and their new friend stiller the elf voice
of ben stiller are going to count down to

elmo s countdown to christmas sesame street board book - Dec 31 2022

web this holiday lift the flap board book is the perfect gift for sesame street fans girls and boys ages 2 to 5 will have great fun
finding more than 30 flaps to lift in this sturdy board

elmo s countdown to christmas sesame street lift the flap - Mar 02 2023

web this holiday lift the flap board book is the perfect gift for sesame street fans girls and boys ages 2 to 5 will have great fun
finding more than 30 flaps to lift in this sturdy board

sesame street countdown to christmas youtube - Nov 17 2021

web sesame street elmo s merry christmas sesame street 2011 10 25 count down to christmas with elmo and his friends in
this holiday flap book includes a built in

sesame street elmo s christmas countdown google play - Oct 29 2022

web elmo s christmas countdown 2007 youtube 0 00 34 09 sesame street characters help elmo count down the days leading
up to christmas

elmo s countdown to christmas kleinberg naomi author free - May 04 2023

web elmo and his friends enjoy christmas activities including playing in the snow giving gifts and singing carols cover title on
board pages at head of title 123 sesame street over

sesame street elmo s christmas songs compilation youtube - Feb 18 2022

web sesame street elmo s christmas countdown streaming where to watch online you can buy sesame street elmo s christmas countdown on amazon video google

[sesame street elmo s christmas countdown apple tv](#) - Apr 22 2022

web dec 17 2017 sesame street elmo s christmas countdown kids global 72 2k subscribers subscribe share save 4 1k views 5 years ago elmo promises to help the

sesame street elmo s christmas countdown sesame - Sep 08 2023

web feb 2 2022 sesame street elmo s christmas countdown by sesame workshop publication date 2007 usage public domain mark 1 0 topics sesame street elmo

secondary geography oxford university press china - Dec 11 2022

web junior secondary exploring geography third edition is written specially for the latest geography curriculum guide secondary 1 3 the series consists of 11 books and is divided into core and elective modules

[junior secondary exploring geography workbook 4 answer](#) - Jul 06 2022

web apr 11 2023 junior secondary exploring geography workbook 4 answer 2 6 downloaded from uniport edu ng on april 11 2023 by guest through clearly written integrated and linked topics a full range of key skills activities promotes active learning important geographical skills such as mapwork and data management are taught

[junior secondary exploring geography workbook 4 answer](#) - May 04 2022

web nov 2 2022 junior secondary exploring geography workbook 4 answer 2 10 downloaded from cob cob utsa edu on november 2 2022 by guest disciplines economies industries and governments and even challenging ideas about what it means to be human artificial intelligence is already all around us from supercomputers drones and virtual

junior secondary exploring geography workbook 4 answer 2023 - Jul 18 2023

web lesson as well as background knowledge and geographical information for specialist and non specialist teachers alike 180 days of geography for kindergarten mar 01 2023 180 days of geography is a fun and effective daily practice workbook designed to help students learn about geography

junior secondary exploring geography workbook 4 answer - Mar 02 2022

web apr 28 2023 junior secondary exploring geography workbook 4 answer 1 11 downloaded from uniport edu ng on april 28 2023 by guest junior secondary exploring geography workbook 4 answer right here we have countless book junior secondary exploring geography workbook 4 answer and collections to check out

junior secondary exploring geography second edition book 4 - Feb 01 2022

web jun 14 2018 junior secondary exploring geography second edition book 4 the trouble with water include 2020 eresources pack oxford university press china 1 home junior secondary exploring geography second edition book 4 the

trouble with water include 2020 eresources pack

[lsforum net hkdse hkal](#) - Mar 14 2023

web we would like to show you a description here but the site won t allow us

[junior secondary exploring geography third edition oxford](#) - May 16 2023

web the new series is designed to simplify teachers teaching process and enhance students concept acquisition with a wide range of teaching materials and digital supports junior secondary exploring geography third edition motivates students to build up their knowledge and skills for geography and also cater for the needs of blended learning

[junior secondary exploring geography workbook 4 answer](#) - Dec 31 2021

web apr 17 2023 junior secondary exploring geography workbook 4 answer when people should go to the books stores

search establishment by shop shelf by shelf it is in fact problematic this is why we give the book compilations in this website

it will certainly ease you to see guide junior secondary exploring geography workbook 4 answer as

[junior secondary exploring geography workbook 4 answer](#) - Aug 07 2022

web may 13 2023 junior secondary exploring geography workbook 4 answer 3 9 downloaded from uniport edu ng on may 13

2023 by guest the world book encyclopedia 2002 an encyclopedia designed especially to meet the needs of elementary junior

high and senior high school students geog 3 rosemarie gallagher 2015 03 01 a new edition

secondary one ccc chuen yuen college - Oct 09 2022

web junior secondary exploring geography 4 scramble for energy with bilingual online e book with english pronunciation

second term ip lam wong lee oxford 110 00 22 junior secondary exploring geography 3 workbook first term ip lam wong lee

oxford 40 00 23 junior secondary exploring geography 4 workbook second term

[get the free exploring geography 1 answer form pdfiller](#) - Nov 10 2022

web exploring geography 1 should include information about the geographic features of a particular region such as its

topography climate vegetation and population it should also include information about the history and culture of the region

as well as any current issues or challenges that the region is facing

junior secondary exploring geography third edition 4 course hero - Apr 15 2023

web junior secondary exploring geography third edition 4 the trouble of water part test a refer figure 2a i identify water

problem x 1 mark ii explain the causes of the water problem in shenzhen in 2021 support your answers with

[answers secondary oxford university press](#) - Jun 17 2023

web cambridge lower secondary complete english second edition complete computer science for cambridge igcse o level myp

mathematics a concept based approach myp sciences a concept based approach ib history ib dp science 2023 cxc study

guides activate ks3 science gcse 9 1 geography aqa tricolore 5e édition

junior secondary exploring geography workbook 4 answer - Feb 13 2023

web junior secondary exploring geography workbook 4 answer downloaded from ams istanbul edu tr by guest raiden li from paragraph to essay panpac education pte ltd cyclone provides everything you need for junior cycle geography written by experienced teachers with extensive knowledge of the junior cycle framework this

junior secondary exploring geography workbook 4 answer - Apr 03 2022

web the costs its more or less what you dependence currently this junior secondary exploring geography workbook 4 answer as one of the most keen sellers here will entirely be in the middle of the best options to review junior secondary exploring geography workbook 4 answer 2021 10 21 mack patricia 11 mc e 1st doc

teaching and learning resources centre - Aug 19 2023

web junior geog 2nd ed map reading exercise 4 in question bank and google forms is now available the brand new teaching resource centre for senior secondary exploring geography third edition is now open 15 02 2019 2nd ed the answers for workbooks have been uploaded 03 10 2017 junior geog 2nd ed the

junior secondary exploring geography second edition work book 4 - Jan 12 2023

web jul 13 2017 junior secondary exploring geography second edition book 3 food problems include 2020 eresources pack ip lam wong tsui h junior secondary exploring geography second edition book 4 the trouble with water include 2020 eresources pack

junior secondary exploring geography workbook 4 answer - Sep 08 2022

web recognizing the mannerism ways to acquire this book junior secondary exploring geography workbook 4 answer is additionally useful you have remained in right site to start getting this info acquire the junior secondary exploring geography workbook 4 answer partner that we pay for here and check out the link

junior secondary exploring geography workbook 4 answer - Jun 05 2022

web junior secondary exploring geography workbook 4 answer is universally compatible with any devices to read the scottish educational journal 1920 the academy 1905

france 24 international breaking news top stories and headlines - Dec 18 2022

latest world news news comment and analysis from the guardian the world s leading liberal voice

İstanbul haberleri ntv haber - Dec 06 2021

nbc news breaking news top stories latest world us - Oct 16 2022

ender saraç sonbahar detoksu tbmm dışişleri komisyonu başkanı oktay estonya letonya ve litvanya nın ankara büyükelçilerini kabul etti milli savunma bakanı güler mustafa kemal

İstanbul haber son dakika İstanbul haberleri güncel haberler - Jan 07 2022

reuters breaking international news views - Aug 26 2023

oct 23 2023 the last read find latest news from every corner of the globe at reuters com your online source for breaking international news coverage

the new york times breaking news us news - Mar 21 2023

stay informed with top world news today the associated press aims to keep you up to date with breaking world news stories around the globe

uk bbc news - Nov 05 2021

world news breaking news video headlines and opinion cnn - Jul 25 2023

visit bbc news for up to the minute news breaking news video audio and feature stories bbc news provides trusted world and uk news as well as local and regional perspectives

İstanbul latest news top stories all news analysis about - Apr 10 2022

İstanbul haberleri ve son dakika gelişmeleri için tıklayın İstanbul ile ilgili en son ve en güncel haber akışı sabah ta

breaking news english lessons easy english world news - Feb 08 2022

the poltergeist that shocked the uk get the latest bbc news breaking news features analysis and debate plus audio and video content from england scotland wales and

[breaking news stories from us and around the world msn news](#) - Jun 12 2022

the latest breaking news comment and features from the independent

news today s latest from al jazeera - Aug 14 2022

get the latest news analysis and events from around the world including updates on coronavirus politics lifestyle and entertainment

home bbc news - Jun 24 2023

get the latest bbc world news international news features and analysis from africa the asia pacific europe latin america the middle east south asia and the united states and

world bbc news - May 23 2023

world news breaking international news and headlines sky news world exclusive all civilian hostages could be freed from gaza in days if fighting paused negotiators say dozens dead

latest news breaking stories and comment the independent - Mar 09 2022

İstanbul haberleri ntv de en güncel ve son dakika İstanbul gelişmeleri için ntv nin İstanbul sayfasını ziyaret edin

[breaking news world news and video from al jazeera](#) - Nov 17 2022

24 oct 2023 stay on top of news latest developments on the ground with al jazeera s fact based news exclusive video footage photos and updated maps

world news top breaking world news today ap news - Jan 19 2023

sep 27 2023 go to nbcnews com for breaking news videos and the latest top stories in world news business politics health and pop culture

latest news from around the world the guardian - Sep 15 2022

get the latest news and follow the coverage of breaking news events local news weird news national and global politics and more from the world s top trusted media outlets

[the latest news from the uk and around the world sky news](#) - Feb 20 2023

france 24 is a global news channel that covers the latest international breaking news top stories and headlines from around the world find out about the powerful morocco earthquake the

world news breaking international news and headlines sky news - Apr 22 2023

follow the latest news from israel and around the world as hamas launches a surprise attack on the country killing at least 22 people and triggering a war declaration from netanyahu watch

breaking news latest news and videos cnn - Sep 27 2023

view the latest news and breaking news today for u s world weather entertainment politics and health at cnn com

[haberler son dakika haberleri ve güncel haber breaking news](#) - Jul 13 2022

research to be initiated on İzmir s quarantine island all news headlines photos and videos on İstanbul track breaking İstanbul headlines analysis on hürriyet daily news

[world news latest breaking international news headlines](#) - May 11 2022

oct 19 2023 learn english with easy news stories from around the world in 7 levels of difficulty topics include health science culture sports and more find podcasts e books and other