

MILL-LESSON-9-EXERCISE-B

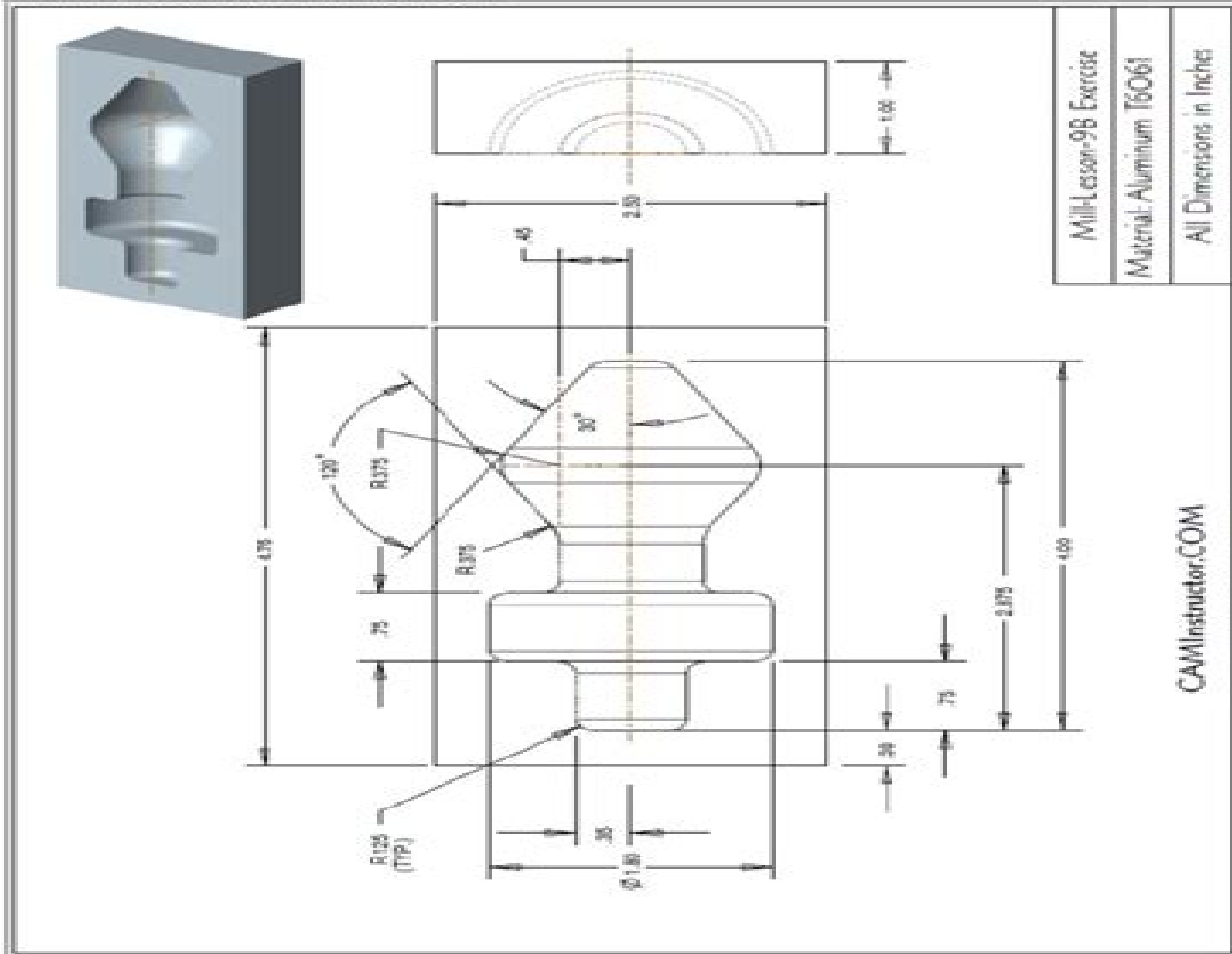

MILL-LESSON-9B Exercise
Material: Aluminum T6061
All Dimensions in Inches

CAMInstructor.COM

# Mastercam Training Guide Mill Lesson 2 Exercise

**JL Elias**



**Mastercam Training Guide Mill Lesson 2 Exercise:**

Immerse yourself in the artistry of words with Experience Art with its expressive creation, Immerse Yourself in **Mastercam Training Guide Mill Lesson 2 Exercise** . This ebook, presented in a PDF format ( PDF Size: \*), is a masterpiece that goes beyond conventional storytelling. Indulge your senses in prose, poetry, and knowledge. Download now to let the beauty of literature and artistry envelop your mind in a unique and expressive way.

[https://staging.conocer.cide.edu/public/detail/HomePages/hp\\_400\\_cone\\_crusher\\_manual.pdf](https://staging.conocer.cide.edu/public/detail/HomePages/hp_400_cone_crusher_manual.pdf)

## **Table of Contents Mastercam Training Guide Mill Lesson 2 Exercise**

1. Understanding the eBook Mastercam Training Guide Mill Lesson 2 Exercise
  - The Rise of Digital Reading Mastercam Training Guide Mill Lesson 2 Exercise
  - Advantages of eBooks Over Traditional Books
2. Identifying Mastercam Training Guide Mill Lesson 2 Exercise
  - Exploring Different Genres
  - Considering Fiction vs. Non-Fiction
  - Determining Your Reading Goals
3. Choosing the Right eBook Platform
  - Popular eBook Platforms
  - Features to Look for in an Mastercam Training Guide Mill Lesson 2 Exercise
  - User-Friendly Interface
4. Exploring eBook Recommendations from Mastercam Training Guide Mill Lesson 2 Exercise
  - Personalized Recommendations
  - Mastercam Training Guide Mill Lesson 2 Exercise User Reviews and Ratings
  - Mastercam Training Guide Mill Lesson 2 Exercise and Bestseller Lists
5. Accessing Mastercam Training Guide Mill Lesson 2 Exercise Free and Paid eBooks
  - Mastercam Training Guide Mill Lesson 2 Exercise Public Domain eBooks
  - Mastercam Training Guide Mill Lesson 2 Exercise eBook Subscription Services
  - Mastercam Training Guide Mill Lesson 2 Exercise Budget-Friendly Options

6. Navigating Mastercam Training Guide Mill Lesson 2 Exercise eBook Formats
  - ePub, PDF, MOBI, and More
  - Mastercam Training Guide Mill Lesson 2 Exercise Compatibility with Devices
  - Mastercam Training Guide Mill Lesson 2 Exercise Enhanced eBook Features
7. Enhancing Your Reading Experience
  - Adjustable Fonts and Text Sizes of Mastercam Training Guide Mill Lesson 2 Exercise
  - Highlighting and Note-Taking Mastercam Training Guide Mill Lesson 2 Exercise
  - Interactive Elements Mastercam Training Guide Mill Lesson 2 Exercise
8. Staying Engaged with Mastercam Training Guide Mill Lesson 2 Exercise
  - Joining Online Reading Communities
  - Participating in Virtual Book Clubs
  - Following Authors and Publishers Mastercam Training Guide Mill Lesson 2 Exercise
9. Balancing eBooks and Physical Books Mastercam Training Guide Mill Lesson 2 Exercise
  - Benefits of a Digital Library
  - Creating a Diverse Reading Collection Mastercam Training Guide Mill Lesson 2 Exercise
10. Overcoming Reading Challenges
  - Dealing with Digital Eye Strain
  - Minimizing Distractions
  - Managing Screen Time
11. Cultivating a Reading Routine Mastercam Training Guide Mill Lesson 2 Exercise
  - Setting Reading Goals Mastercam Training Guide Mill Lesson 2 Exercise
  - Carving Out Dedicated Reading Time
12. Sourcing Reliable Information of Mastercam Training Guide Mill Lesson 2 Exercise
  - Fact-Checking eBook Content of Mastercam Training Guide Mill Lesson 2 Exercise
  - Distinguishing Credible Sources
13. Promoting Lifelong Learning
  - Utilizing eBooks for Skill Development
  - Exploring Educational eBooks
14. Embracing eBook Trends
  - Integration of Multimedia Elements

- Interactive and Gamified eBooks

## **Mastercam Training Guide Mill Lesson 2 Exercise Introduction**

Free PDF Books and Manuals for Download: Unlocking Knowledge at Your Fingertips In today's fast-paced digital age, obtaining valuable knowledge has become easier than ever. Thanks to the internet, a vast array of books and manuals are now available for free download in PDF format. Whether you are a student, professional, or simply an avid reader, this treasure trove of downloadable resources offers a wealth of information, conveniently accessible anytime, anywhere. The advent of online libraries and platforms dedicated to sharing knowledge has revolutionized the way we consume information. No longer confined to physical libraries or bookstores, readers can now access an extensive collection of digital books and manuals with just a few clicks. These resources, available in PDF, Microsoft Word, and PowerPoint formats, cater to a wide range of interests, including literature, technology, science, history, and much more. One notable platform where you can explore and download free Mastercam Training Guide Mill Lesson 2 Exercise PDF books and manuals is the internet's largest free library. Hosted online, this catalog compiles a vast assortment of documents, making it a veritable goldmine of knowledge. With its easy-to-use website interface and customizable PDF generator, this platform offers a user-friendly experience, allowing individuals to effortlessly navigate and access the information they seek. The availability of free PDF books and manuals on this platform demonstrates its commitment to democratizing education and empowering individuals with the tools needed to succeed in their chosen fields. It allows anyone, regardless of their background or financial limitations, to expand their horizons and gain insights from experts in various disciplines. One of the most significant advantages of downloading PDF books and manuals lies in their portability. Unlike physical copies, digital books can be stored and carried on a single device, such as a tablet or smartphone, saving valuable space and weight. This convenience makes it possible for readers to have their entire library at their fingertips, whether they are commuting, traveling, or simply enjoying a lazy afternoon at home. Additionally, digital files are easily searchable, enabling readers to locate specific information within seconds. With a few keystrokes, users can search for keywords, topics, or phrases, making research and finding relevant information a breeze. This efficiency saves time and effort, streamlining the learning process and allowing individuals to focus on extracting the information they need. Furthermore, the availability of free PDF books and manuals fosters a culture of continuous learning. By removing financial barriers, more people can access educational resources and pursue lifelong learning, contributing to personal growth and professional development. This democratization of knowledge promotes intellectual curiosity and empowers individuals to become lifelong learners, promoting progress and innovation in various fields. It is worth noting that while accessing free Mastercam Training Guide Mill Lesson 2 Exercise PDF books and manuals is convenient and cost-effective, it is vital to respect copyright laws and intellectual property rights. Platforms

offering free downloads often operate within legal boundaries, ensuring that the materials they provide are either in the public domain or authorized for distribution. By adhering to copyright laws, users can enjoy the benefits of free access to knowledge while supporting the authors and publishers who make these resources available. In conclusion, the availability of Mastercam Training Guide Mill Lesson 2 Excercise free PDF books and manuals for download has revolutionized the way we access and consume knowledge. With just a few clicks, individuals can explore a vast collection of resources across different disciplines, all free of charge. This accessibility empowers individuals to become lifelong learners, contributing to personal growth, professional development, and the advancement of society as a whole. So why not unlock a world of knowledge today? Start exploring the vast sea of free PDF books and manuals waiting to be discovered right at your fingertips.

### **FAQs About Mastercam Training Guide Mill Lesson 2 Excercise Books**

How do I know which eBook platform is the best for me? Finding the best eBook platform depends on your reading preferences and device compatibility. Research different platforms, read user reviews, and explore their features before making a choice. Are free eBooks of good quality? Yes, many reputable platforms offer high-quality free eBooks, including classics and public domain works. However, make sure to verify the source to ensure the eBook credibility. Can I read eBooks without an eReader? Absolutely! Most eBook platforms offer webbased readers or mobile apps that allow you to read eBooks on your computer, tablet, or smartphone. How do I avoid digital eye strain while reading eBooks? To prevent digital eye strain, take regular breaks, adjust the font size and background color, and ensure proper lighting while reading eBooks. What the advantage of interactive eBooks? Interactive eBooks incorporate multimedia elements, quizzes, and activities, enhancing the reader engagement and providing a more immersive learning experience. Mastercam Training Guide Mill Lesson 2 Excercise is one of the best book in our library for free trial. We provide copy of Mastercam Training Guide Mill Lesson 2 Excercise in digital format, so the resources that you find are reliable. There are also many Ebooks of related with Mastercam Training Guide Mill Lesson 2 Excercise. Where to download Mastercam Training Guide Mill Lesson 2 Excercise online for free? Are you looking for Mastercam Training Guide Mill Lesson 2 Excercise PDF? This is definitely going to save you time and cash in something you should think about. If you trying to find then search around for online. Without a doubt there are numerous these available and many of them have the freedom. However without doubt you receive whatever you purchase. An alternate way to get ideas is always to check another Mastercam Training Guide Mill Lesson 2 Excercise. This method for see exactly what may be included and adopt these ideas to your book. This site will almost certainly help you save time and effort, money and stress. If you are looking for free books then you really should consider finding to assist you try this. Several of Mastercam Training Guide Mill Lesson 2 Excercise are for sale to free while some are payable. If you arent

sure if the books you would like to download works with for usage along with your computer, it is possible to download free trials. The free guides make it easy for someone to free access online library for download books to your device. You can get free download on free trial for lots of books categories. Our library is the biggest of these that have literally hundreds of thousands of different products categories represented. You will also see that there are specific sites catered to different product types or categories, brands or niches related with Mastercam Training Guide Mill Lesson 2 Exercise. So depending on what exactly you are searching, you will be able to choose e books to suit your own need. Need to access completely for Campbell Biology Seventh Edition book? Access Ebook without any digging. And by having access to our ebook online or by storing it on your computer, you have convenient answers with Mastercam Training Guide Mill Lesson 2 Exercise To get started finding Mastercam Training Guide Mill Lesson 2 Exercise, you are right to find our website which has a comprehensive collection of books online. Our library is the biggest of these that have literally hundreds of thousands of different products represented. You will also see that there are specific sites catered to different categories or niches related with Mastercam Training Guide Mill Lesson 2 Exercise So depending on what exactly you are searching, you will be able to choose ebook to suit your own need. Thank you for reading Mastercam Training Guide Mill Lesson 2 Exercise. Maybe you have knowledge that, people have search numerous times for their favorite readings like this Mastercam Training Guide Mill Lesson 2 Exercise, but end up in harmful downloads. Rather than reading a good book with a cup of coffee in the afternoon, instead they juggled with some harmful bugs inside their laptop. Mastercam Training Guide Mill Lesson 2 Exercise is available in our book collection an online access to it is set as public so you can download it instantly. Our digital library spans in multiple locations, allowing you to get the most less latency time to download any of our books like this one. Merely said, Mastercam Training Guide Mill Lesson 2 Exercise is universally compatible with any devices to read.

**Find Mastercam Training Guide Mill Lesson 2 Exercise :**

*hp 400 cone crusher manual*

**hp dv4394 laptops owners manual**

[hp 4l printer manual](#)

**hp dv8221 laptops owners manual**

*hp compaq nc6120 user manual*

**hp 7515 manual**

**hp 60 ink refill instructions**

**hp designjet 450 manual**

**hp dv2143 laptops owners manual**



[hp cp1025nw service manual](#)

[hp deskjet f340 all in one owners manual](#)

**hp data protector 7 admin guide**

[hp deskjet f390 user manual](#)

**hp deskjet f380 manual de**

~~[hp 600k printers owners manual](#)~~

### Mastercam Training Guide Mill Lesson 2 Exercise :

[a basic text for individualized study] (The Radio amateur's ... A course in radio fundamentals;: [a basic text for individualized study] (The Radio amateur's library, publication) [Grammer, George] on Amazon.com. A course in radio fundamentals on the part of radio amateurs for a course of study emphasizing the fundamentals upon which practical radio communication is built. It originally appeared ... A Course in Radio Fundamentals A Course in Radio Fundamentals. Lessons in Radio Theory for the Amateur. BY GEORGE GRAMMER,\* WIDF. No. 6-Modulation. THE present installment deals with various. A course in radio fundamentals : study assignments ... A course in radio fundamentals : study assignments, experiments and examination questions, based on the radio amateur's handbook. A course in radio fundamentals; study assignments ... Title: A course in radio fundamentals; study assignments, experiments, and examination questions. No stable link: A Course in Radio Fundamentals - George Grammer A Course in Radio Fundamentals: Study Assignments, Experiments and ... George Grammer Snippet view - ... course radio fundamentals A course in radio fundamentals : study assignments, experiments and examination... Grammer, George. Seller: Dorothy Meyer - Bookseller Batavia, IL, U.S.A.. A Course in Radio Fundamentals RADIO FUNDAMENTALS in the common lead between the source of voltage and the parallel combination? 13) What are the reactances of the choke coil and fixed ... A Course in Radio Fundamentals - A Basic Text for ... A Course in Radio Fundamentals - A Basic Text for Individualized Study - No. 19 of the Radio Amateur's Library. Grammer, George. Published by The American Radio ... Indian art by vidya dehejia hourly [PDF] Looking Again at Indian Art The Republic of India World Development Report 2013 Indigenous Peoples, Poverty, and Development Student Participation in ... Indian Art: Dehejia, Vidya Dehejia, curator of the Smithsonian's Indian and Southeast Asian collection, surveys the full breadth of artistic traditions from ancient times to the present. Vidya Dehejia on Bronzes of Chola India, Part 3 - YouTube Solid Treasure | A Straight Talk by Vidya Dehejia - YouTube By Vidya Dehejia Indian Art Starts from ancient times of civilization 2600-1900 bc, showing the Mohenjodaro city to the modern Indian markets of 1997. Beautiful photographs. The body adorned : dissolving boundaries between sacred ... Feb 12, 2020 — The body adorned : dissolving boundaries between sacred and profane in India's art. by: Dehejia, Vidya. Publication date ... vidya dehejia Archives - yogawithpragya ... India of today, it no longer is so.

... In fact, I got a personal tour where I learned about the themes and techniques of the dying art of Kangra style painting. Vidya Dehejia on Bronzes of Chola India, Part 1 - YouTube Vidya Dehejia (ed.), Representing the Body: Gender Issues in ... Book Reviews : Vidya Dehejia (ed.), Representing the Body: Gender Issues in Indian Art. ... Purchase 24 hour online access to view and download content. Article ... Foreign Relations of the United States, 1949, The Far East: ... The China White Paper was released by the Department at 12 noon, August 5, as ... August 15, 1949, page 237. The statement issued by the Secretary of State ... China White Paper The China White Paper is the common name for United States Relations with China, with Special Reference to the Period 1944-1949, published in August 1949 by ... The China White Paper: August 1949 - U. S. Department of ... U. S. Department of State Introduction by Lyman P. Van Slyke. BUY THIS BOOK. 1967 1124 pages. \$65.00. Paperback ISBN: 9780804706087. Google Book Preview. The Failure of the China White Paper - Digital Commons @ IWU by WA Rintz · 2009 · Cited by 8 — Abstract. The China White Paper, released by the Truman administration in 1949, aimed to absolve the U.S. government of responsibility for the loss of China ... Dean Acheson's 'White Paper' on China (1949) Published in early August 1949, it outlined the situation in China, detailed American involvement and assistance to the Chinese and suggested reasons for the ... Publication of China White Paper Work was under way in April 1949 (026 China/4-2749). A memorandum of May 21 ... Canton, August 10, 1949—2 p. m. [Received August 13—6:12 a. m.]. 893.00/8 ... The China White Paper: August 1949 - U. S. Department of ... U. S. Department of State Introduction by Lyman P. Van Slyke. BUY THIS BOOK. 1967 1124 pages. \$65.00. Paperback ISBN: 9780804706087. Google Book Preview. The China White Paper: August 1949 Book details · Print length. 1086 pages · Language. English · Publisher. Stanford University Press · Publication date. December 1, 1967 · ISBN-10. 0804706077. Full text of "The China White Paper 1949" Full text of "The China White Paper 1949". See other formats. SP 63 / Two volumes, \$7.50 a set CHINA WHITE PAPER August 1949 VOLUME I Originally Issued as ... The China White Paper: August 1949 A Stanford University Press classic.