

BRIGGS AND STRATTON ENGINE - MODEL NO. 137202-1117-E1

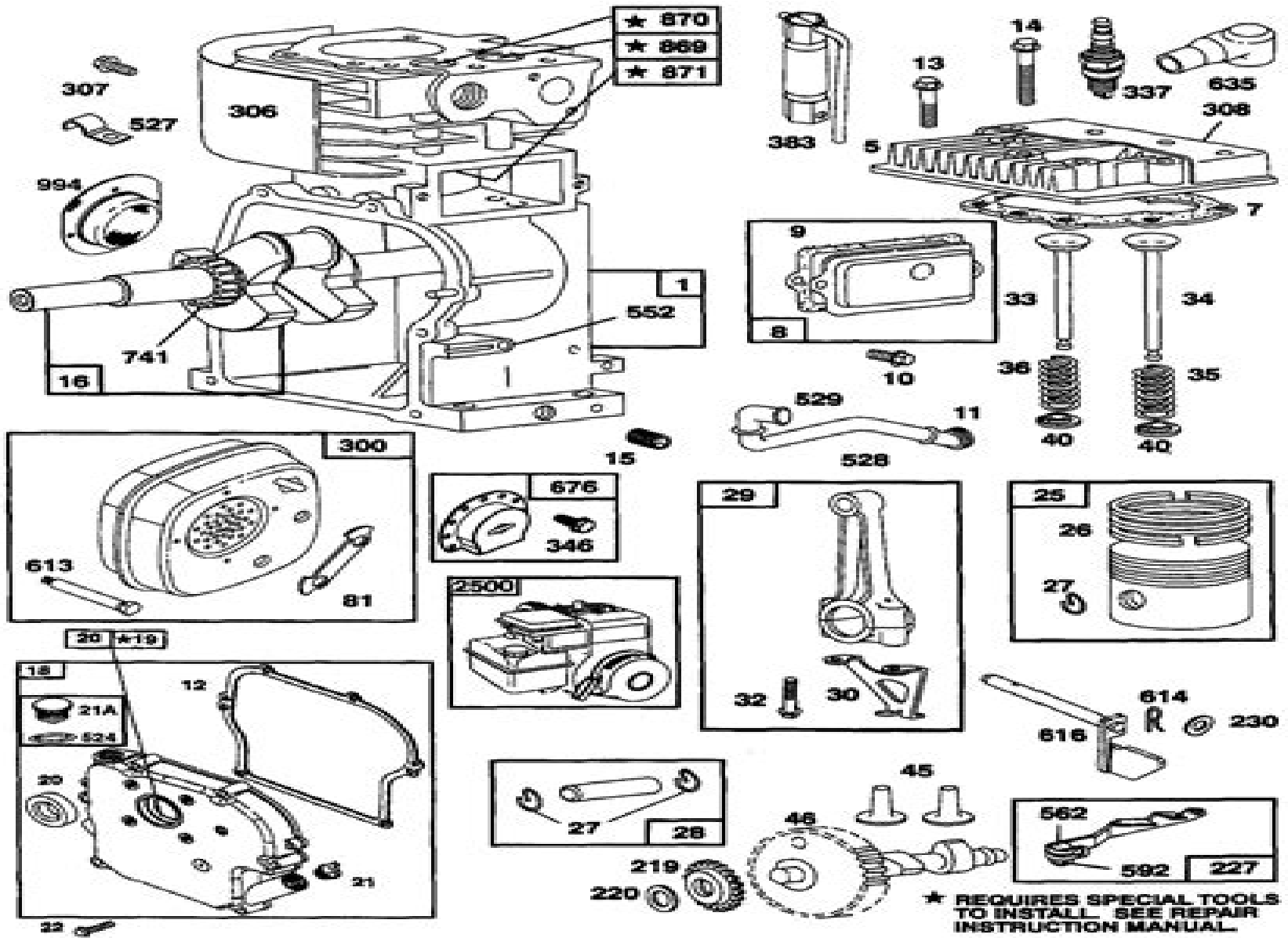

★ REQUIRES SPECIAL TOOLS TO INSTALL. SEE REPAIR INSTRUCTION MANUAL.

# Manual For 5hp Briggs And Stratton

**A Gutmann**



## **Manual For 5hp Briggs And Stratton:**

Embark on a breathtaking journey through nature and adventure with Crafted by is mesmerizing ebook, **Manual For 5hp Briggs And Stratton** . This immersive experience, available for download in a PDF format ( Download in PDF: \*), transports you to the heart of natural marvels and thrilling escapades. Download now and let the adventure begin!

<https://staging.conocer.cide.edu/files/Resources/fetch.php/Exploring%20Conic%20Sections%20Answer%20Key.pdf>

## **Table of Contents Manual For 5hp Briggs And Stratton**

1. Understanding the eBook Manual For 5hp Briggs And Stratton
  - The Rise of Digital Reading Manual For 5hp Briggs And Stratton
  - Advantages of eBooks Over Traditional Books
2. Identifying Manual For 5hp Briggs And Stratton
  - Exploring Different Genres
  - Considering Fiction vs. Non-Fiction
  - Determining Your Reading Goals
3. Choosing the Right eBook Platform
  - Popular eBook Platforms
  - Features to Look for in an Manual For 5hp Briggs And Stratton
  - User-Friendly Interface
4. Exploring eBook Recommendations from Manual For 5hp Briggs And Stratton
  - Personalized Recommendations
  - Manual For 5hp Briggs And Stratton User Reviews and Ratings
  - Manual For 5hp Briggs And Stratton and Bestseller Lists
5. Accessing Manual For 5hp Briggs And Stratton Free and Paid eBooks
  - Manual For 5hp Briggs And Stratton Public Domain eBooks
  - Manual For 5hp Briggs And Stratton eBook Subscription Services
  - Manual For 5hp Briggs And Stratton Budget-Friendly Options
6. Navigating Manual For 5hp Briggs And Stratton eBook Formats

- ePub, PDF, MOBI, and More
  - Manual For 5hp Briggs And Stratton Compatibility with Devices
  - Manual For 5hp Briggs And Stratton Enhanced eBook Features
7. Enhancing Your Reading Experience
    - Adjustable Fonts and Text Sizes of Manual For 5hp Briggs And Stratton
    - Highlighting and Note-Taking Manual For 5hp Briggs And Stratton
    - Interactive Elements Manual For 5hp Briggs And Stratton
  8. Staying Engaged with Manual For 5hp Briggs And Stratton
    - Joining Online Reading Communities
    - Participating in Virtual Book Clubs
    - Following Authors and Publishers Manual For 5hp Briggs And Stratton
  9. Balancing eBooks and Physical Books Manual For 5hp Briggs And Stratton
    - Benefits of a Digital Library
    - Creating a Diverse Reading Collection Manual For 5hp Briggs And Stratton
  10. Overcoming Reading Challenges
    - Dealing with Digital Eye Strain
    - Minimizing Distractions
    - Managing Screen Time
  11. Cultivating a Reading Routine Manual For 5hp Briggs And Stratton
    - Setting Reading Goals Manual For 5hp Briggs And Stratton
    - Carving Out Dedicated Reading Time
  12. Sourcing Reliable Information of Manual For 5hp Briggs And Stratton
    - Fact-Checking eBook Content of Manual For 5hp Briggs And Stratton
    - Distinguishing Credible Sources
  13. Promoting Lifelong Learning
    - Utilizing eBooks for Skill Development
    - Exploring Educational eBooks
  14. Embracing eBook Trends
    - Integration of Multimedia Elements
    - Interactive and Gamified eBooks

## Manual For 5hp Briggs And Stratton Introduction

In today's digital age, the availability of Manual For 5hp Briggs And Stratton books and manuals for download has revolutionized the way we access information. Gone are the days of physically flipping through pages and carrying heavy textbooks or manuals. With just a few clicks, we can now access a wealth of knowledge from the comfort of our own homes or on the go. This article will explore the advantages of Manual For 5hp Briggs And Stratton books and manuals for download, along with some popular platforms that offer these resources. One of the significant advantages of Manual For 5hp Briggs And Stratton books and manuals for download is the cost-saving aspect. Traditional books and manuals can be costly, especially if you need to purchase several of them for educational or professional purposes. By accessing Manual For 5hp Briggs And Stratton versions, you eliminate the need to spend money on physical copies. This not only saves you money but also reduces the environmental impact associated with book production and transportation. Furthermore, Manual For 5hp Briggs And Stratton books and manuals for download are incredibly convenient. With just a computer or smartphone and an internet connection, you can access a vast library of resources on any subject imaginable. Whether you're a student looking for textbooks, a professional seeking industry-specific manuals, or someone interested in self-improvement, these digital resources provide an efficient and accessible means of acquiring knowledge. Moreover, PDF books and manuals offer a range of benefits compared to other digital formats. PDF files are designed to retain their formatting regardless of the device used to open them. This ensures that the content appears exactly as intended by the author, with no loss of formatting or missing graphics. Additionally, PDF files can be easily annotated, bookmarked, and searched for specific terms, making them highly practical for studying or referencing. When it comes to accessing Manual For 5hp Briggs And Stratton books and manuals, several platforms offer an extensive collection of resources. One such platform is Project Gutenberg, a nonprofit organization that provides over 60,000 free eBooks. These books are primarily in the public domain, meaning they can be freely distributed and downloaded. Project Gutenberg offers a wide range of classic literature, making it an excellent resource for literature enthusiasts. Another popular platform for Manual For 5hp Briggs And Stratton books and manuals is Open Library. Open Library is an initiative of the Internet Archive, a non-profit organization dedicated to digitizing cultural artifacts and making them accessible to the public. Open Library hosts millions of books, including both public domain works and contemporary titles. It also allows users to borrow digital copies of certain books for a limited period, similar to a library lending system. Additionally, many universities and educational institutions have their own digital libraries that provide free access to PDF books and manuals. These libraries often offer academic texts, research papers, and technical manuals, making them invaluable resources for students and researchers. Some notable examples include MIT OpenCourseWare, which offers free access to course materials from the Massachusetts Institute of Technology, and the Digital Public Library of America, which provides a vast collection of digitized books and historical documents. In conclusion, Manual For 5hp Briggs

And Stratton books and manuals for download have transformed the way we access information. They provide a cost-effective and convenient means of acquiring knowledge, offering the ability to access a vast library of resources at our fingertips. With platforms like Project Gutenberg, Open Library, and various digital libraries offered by educational institutions, we have access to an ever-expanding collection of books and manuals. Whether for educational, professional, or personal purposes, these digital resources serve as valuable tools for continuous learning and self-improvement. So why not take advantage of the vast world of Manual For 5hp Briggs And Stratton books and manuals for download and embark on your journey of knowledge?

### **FAQs About Manual For 5hp Briggs And Stratton Books**

How do I know which eBook platform is the best for me? Finding the best eBook platform depends on your reading preferences and device compatibility. Research different platforms, read user reviews, and explore their features before making a choice. Are free eBooks of good quality? Yes, many reputable platforms offer high-quality free eBooks, including classics and public domain works. However, make sure to verify the source to ensure the eBook credibility. Can I read eBooks without an eReader? Absolutely! Most eBook platforms offer webbased readers or mobile apps that allow you to read eBooks on your computer, tablet, or smartphone. How do I avoid digital eye strain while reading eBooks? To prevent digital eye strain, take regular breaks, adjust the font size and background color, and ensure proper lighting while reading eBooks. What the advantage of interactive eBooks? Interactive eBooks incorporate multimedia elements, quizzes, and activities, enhancing the reader engagement and providing a more immersive learning experience. Manual For 5hp Briggs And Stratton is one of the best book in our library for free trial. We provide copy of Manual For 5hp Briggs And Stratton in digital format, so the resources that you find are reliable. There are also many Ebooks of related with Manual For 5hp Briggs And Stratton. Where to download Manual For 5hp Briggs And Stratton online for free? Are you looking for Manual For 5hp Briggs And Stratton PDF? This is definitely going to save you time and cash in something you should think about. If you trying to find then search around for online. Without a doubt there are numerous these available and many of them have the freedom. However without doubt you receive whatever you purchase. An alternate way to get ideas is always to check another Manual For 5hp Briggs And Stratton. This method for see exactly what may be included and adopt these ideas to your book. This site will almost certainly help you save time and effort, money and stress. If you are looking for free books then you really should consider finding to assist you try this. Several of Manual For 5hp Briggs And Stratton are for sale to free while some are payable. If you arent sure if the books you would like to download works with for usage along with your computer, it is possible to download free trials. The free guides make it easy for someone to free access online library for download books to

your device. You can get free download on free trial for lots of books categories. Our library is the biggest of these that have literally hundreds of thousands of different products categories represented. You will also see that there are specific sites catered to different product types or categories, brands or niches related with Manual For 5hp Briggs And Stratton. So depending on what exactly you are searching, you will be able to choose e books to suit your own need. Need to access completely for Campbell Biology Seventh Edition book? Access Ebook without any digging. And by having access to our ebook online or by storing it on your computer, you have convenient answers with Manual For 5hp Briggs And Stratton To get started finding Manual For 5hp Briggs And Stratton, you are right to find our website which has a comprehensive collection of books online. Our library is the biggest of these that have literally hundreds of thousands of different products represented. You will also see that there are specific sites catered to different categories or niches related with Manual For 5hp Briggs And Stratton So depending on what exactly you are searching, you will be able to choose ebook to suit your own need. Thank you for reading Manual For 5hp Briggs And Stratton. Maybe you have knowledge that, people have search numerous times for their favorite readings like this Manual For 5hp Briggs And Stratton, but end up in harmful downloads. Rather than reading a good book with a cup of coffee in the afternoon, instead they juggled with some harmful bugs inside their laptop. Manual For 5hp Briggs And Stratton is available in our book collection an online access to it is set as public so you can download it instantly. Our digital library spans in multiple locations, allowing you to get the most less latency time to download any of our books like this one. Merely said, Manual For 5hp Briggs And Stratton is universally compatible with any devices to read.

### **Find Manual For 5hp Briggs And Stratton :**

*exploring conic sections answer key*

*exponent practice 2 page 27 of 67*

*ezgo electric golf cart service manual 1994*

**exponent practice 2 answer key**

*exploring similarity geometry hs mathematics unit 09 lesson 01*

*exponent practice 1 and 2 tesccc*

*expresate 3 chapter 2 workbook answers*

**extra pounds guideline of minimizing your extra pounds**

*exploring science for qca copymaster file 8b*

**f214 summer 2014 mark scheme**

*exposed misbehaving with the magnate*



~~explore learning gizmo answer key gravitational force~~

## **f 800 gs shop manual**

~~extending mendelian genetics study guide book answers~~

~~extreme papers biology paper 2013~~

### **Manual For 5hp Briggs And Stratton :**

*the outcome generation how a new generation of* - Sep 17 2023

web aug 23 2018 you ll learn how to increase new business new logo sales by employing the third generation of technology sales selling outcomes and exactly what type of outcome to sell using the third generation approach you ll create greater emotional connections

**the outcome generation how a new generation of te** - Mar 31 2022

web books the outcome generation how a new generation of te is additionally useful you have remained in right site to begin getting this info get the the outcome generation

the outcome generation how a new generation of - May 13 2023

web the outcome generation shows how to align the whole business around a common theme enabling outcomes the customers regard as success and why that allows

**the outcome generation how a new generation of te** - Oct 06 2022

web the outcome generation how a new generation of te the outcome generation how a new generation of te 2 downloaded from old restorativejustice org on 2022 12 18 by

the outcome generation how a new generation - Nov 26 2021

web sep 2 2023 the outcome generation how a new generation of te 2 11 downloaded from uniport edu ng on september 2 2023 by guest generation transistors

**the outcome generation how a new generation of te pdf** - Oct 26 2021

the outcome generation how a new generation of te pdf - Dec 08 2022

web currently this the outcome generation how a new generation of te as one of the most vigorous sellers here will utterly be in the middle of the best options to review a new

**the outcome generation how a new generation of te pdf** - Sep 05 2022

web jul 21 2023 outcome generation how a new generation of te is universally compatible subsequent to any devices to read new generation political activism in ukraine

the outcome generation how a new generation of - Jan 09 2023

web aug 21 2018 the outcome generation how a new generation of technology vendors thrives through true customer success by paul j henderson write a review

*download solutions the outcome generation how a new* - May 01 2022

web new generation jan 21 2022 composting for a new generation covers the ins and outs of modern composting techniques including vermicomposting composting with nature

**the outcome generation how a new generation of te pdf** - Nov 07 2022

web jun 4 2023 the outcome generation how a new generation of te 1 15 downloaded from uniport edu ng on june 4 2023 by guest the outcome generation how a new

**the outcome generation how a new generation of te** - Jul 03 2022

web right here we have countless ebook the outcome generation how a new generation of te and collections to check out we additionally give variant types and next type of

**the outcome generation** - Mar 11 2023

web the outcome generation how a new generation of technology vendors thrives through true customer success iii red raven books publisher the copy

**pdf book the outcome generation how a new** - Apr 12 2023

web apr 14 2022 they have a new approach to enabling success for their customers and they re thriving as a result strongthese vendors all have subscription pricing at the heart

*main menu new higher education academy* - Jan 29 2022

web jul 1 2012 induction to higher education governance for new governors new governors of scottish heis role and responsibilities of staff governors student governor 1

**the outcome generation how a new generation of te pdf** - Jul 15 2023

web the outcome generation how a new generation of te second generation cell and gene based therapies apr 19 2022 second generation cell and gene based

the outcome generation how a new generation of technol - Aug 16 2023

web aug 23 2018 the outcome generation how a new generation of technology vendors thrives through true customer success paul henderson 3 82 39 ratings1 review

the outcome generation how a new generation of te s smys - Jun 02 2022

web the notice the outcome generation how a new generation of te that you are looking for it will categorically squander the time however below taking into account you visit

*what is the outcome of evolution researchgate* - Feb 27 2022

web mar 8 2014 abstract the question of qualitative changes during the major transitions in evolution is developed in this chapter the concept is introduced that among these

**the outcome generation how a new generation of te pdf** - Jun 14 2023

web 4 the outcome generation how a new generation of te 2022 01 17 retain donors of all ages fundraising and the next generation brings readers up to date on cases

the outcome generation how a new generation of te - Feb 10 2023

web generation and how governments struggled to accommodate the changes with new policies for improving and managing the nation s capital in terms of education family

the outcome generation how a new generation of te pdf - Aug 04 2022

web sep 19 2023 the outcome generation how a new generation of te 1 14 downloaded from uniport edu ng on september 19 2023 by guest the outcome generation how a

**the outcome generation how a new generation of te tricia** - Dec 28 2021

web the outcome generation how a new generation of te right here we have countless ebook the outcome generation how a new generation of te and collections to

*buck danny l inta c grale tome 2 buck danny 2 int* - Aug 04 2022

web buck danny l inta c grale tome 2 buck danny 2 int downloaded from test downing co uk by guest baker allen the consul city lights books the idea of kantian ethics is both simple and revolutionary it proposes a moral law independent of any notion of a pre establishment of fear in attempting to interpret such a

**buck danny l intégrale tome 2 buck danny l intégrale** - Aug 16 2023

web buck danny l intégrale tome 2 buck danny l intégrale tome 2 charlier jean michel hubinon kim devil avec forton dans l effervescence des agences world puis international press charlier fournit des textes à de nombreux dessinateurs qui vont bientôt devenir les signatures en vue de la bande dessinée tel albert

**buck danny l inta c grale tome 2 buck danny 2 int pdf** - May 13 2023

web mar 23 2023 buck danny l inta c grale tome 2 buck danny 2 int pdf and numerous books collections from fictions to scientific research in any way along with them is this buck danny l inta c grale tome 2 buck danny 2 int pdf that can be your partner industrial maintenance and mechatronics shawn a ballee 2018 09 18

buck danny l inta c grale tome 2 buck danny 2 int pdf full - Nov 07 2022

web buck danny l inta c grale tome 2 buck danny 2 int pdf 1 3 downloaded from control startup network on january 16 2023 by guest buck danny l inta c grale tome 2 buck danny 2 int pdf this is likewise one of the factors by obtaining the soft

documents of this buck danny l inta c grale tome 2 buck danny 2 int pdf by online

**buck danny l inta c grale tome 2 buck danny 2 int pdf free** - Feb 10 2023

web introduction buck danny l inta c grale tome 2 buck danny 2 int pdf free biopesticides aaron gross 2015 02 23 resistance to conventional pesticides has been growing rapidly among all pests

**buck danny l inta c grale tome 2 buck danny 2 int copy** - Feb 27 2022

web buck danny l inta c grale tome 2 buck danny 2 int 1 buck danny l inta c grale tome 2 buck danny 2 int when somebody should go to the book stores search commencement by shop shelf by shelf it is in fact problematic

[buck danny l inta c grale tome 2 buck danny 2 int pdf download](#) - Jun 14 2023

web danny l inta c grale tome 2 buck danny 2 int book file pdf file buck danny l inta c grale tome 2 buck danny 2 int book free download pdf at our ebook library this book

**buck danny l intégrale tome 2 librairie eyrolles** - Jul 03 2022

web buck danny l intégrale tome 2 librairie eyrolles 1948 1951

**buck danny l inta c grale tome 2 buck danny 2 int pdf** - Mar 31 2022

web it is your agreed own era to take steps reviewing habit in the midst of guides you could enjoy now is buck danny l inta c grale tome 2 buck danny 2 int pdf below buck danny l inta c grale tome 2 buck danny 2 int pdf web nov 5 2022 buck danny l inta c grale tome 2 buck danny 2 int is available

**buck danny l inta c grale tome 2 buck danny 2 int catherine** - Jan 29 2022

web jan 4 2023 4728788 buck danny l inta c grale tome 2 buck danny 2 int 2 4 downloaded from knockinc com on by guest total diet studies gerald g moy 2013 11 08 unless a food is grossly contaminated consumers are unable to detect through sight or smell the presence of low levels of toxic chemicals in their foods

**buck danny l inta c grale tome 2 buck danny 2 int full pdf** - Jan 09 2023

web danny l inta c grale tome 2 buck danny 2 int by online you might not require more times to spend to go to the ebook inauguration as skillfully as search for them

**buck danny l inta c grale tome 2 buck danny 2 int copy** - Dec 28 2021

web may 16 2023 buck danny l inta c grale tome 2 buck danny 2 int is available in our digital library an online access to it is set as public so you can download it instantly our books collection spans in multiple locations allowing you to get the most less latency time

*buck danny l inta c grale tome 2 buck danny 2 int pdf* - Sep 05 2022

web buck danny l inta c grale tome 2 buck danny 2 int grape rootstocks and related species sep 10 2022 this book covers about 20 grape species that are vitally important in breeding programs and provide information on approximately 150 of the

most familiar grape rootstocks in the world

**buck danny l inta c grale tome 2 buck danny 2 int pdf free** - Apr 12 2023

web buck danny l inta c grale tome 2 buck danny 2 int pdf introduction buck danny l inta c grale tome 2 buck danny 2 int pdf free ortax org tax clone ortax org 75140 d pdf goto pdf buck da pdf file webtitle buck danny l inta c grale tome 5 buck danny 5 int pdf free tax clone ortax org created date

**buck danny l inta c grale tome 2 buck danny 2 int pdf** - Dec 08 2022

web buck danny l inta c grale tome 2 buck danny 2 int 1 5 downloaded from staging friends library org on october 28 2022 by guest buck danny l inta c grale tome 2 buck danny 2 int when people should go to the ebook stores search opening by shop shelf by shelf it is in point of fact problematic this is why we offer the book compilations in this

buck danny l inta c grale tome 2 buck danny 2 int 2022 - Jun 02 2022

web we offer buck danny l inta c grale tome 2 buck danny 2 int and numerous book collections from fictions to scientific research in any way in the midst of them is this buck danny l inta c grale tome 2 buck danny 2 int that can be your partner buck danny l inta c grale tome 2 buck danny 2 int 2023 03 28 foley yaretzi the spoils of

buck danny l inta c grale tome 2 buck danny 2 int pdf - Mar 11 2023

web apr 20 2023 buck danny l inta c grale tome 2 buck danny 2 int ebook that will come up with the money for you worth acquire the very best seller from us currently from several preferred authors buck danny l inta c grale tome 2 buck danny 2 int full pdf

**buck danny l intégrale tome 2 tome 2 de la série de bd buck danny** - Jul 15 2023

web mar 4 2011 buck danny l intégrale tome 2 tome 2 de la série de bd buck danny l intégrale de charlier hubinon dupuis patrimoine Éditions dupuis feuilletez gratuitement cette bd en ligne 1948 1951 zone de livraison international vous aimerez aussi toute la série des univers similaires tome 14 buck danny

*buck danny l inta c grale tome 2 buck danny 2 int uniport edu* - Oct 06 2022

web mar 7 2023 buck danny l inta c grale tome 2 buck danny 2 int 2 7 downloaded from uniport edu ng on march 7 2023 by guest advances in herpetology and evolutionary biology ernest edward williams 1983 that winter pamela gillilan 1986 pamela gillilan was born in london in 1918 married in 1948 and moved to cornwall in 1951

buck danny l inta c grale tome 7 buck danny 7 int pdf pdf - May 01 2022

web buck danny l inta c grale tome 7 buck danny 7 int pdf decoding buck danny l inta c grale tome 7 buck danny 7 int pdf revealing the captivating potential of verbal expression in a time characterized by interconnectedness and an insatiable thirst for knowledge the captivating potential of verbal expression has emerged as a formidable

*tải xuống opera mini dành cho điện thoại di động opera* - Feb 06 2023

web truy cập m opera com trên điện thoại của bạn để tải xuống tải xuống opera mini cho điện thoại của bạn ngay bây giờ lưu dữ liệu xem thêm video trên di động mà không phải dừng lại hay có vùng đệm và tăng tốc miễn phí các kết nối chậm

*download opera mini for mobile phones opera* - Oct 14 2023

web opera mini faster cheaper internet for your phone opera mini is one of the world s most popular web browsers that works on almost any phone save up to 90 of your data for free visit m opera com on your phone to download

**nokia 110 4g test full applications youtube** - Jan 05 2023

web jul 10 2021 nokia 110 4g test full applications camera internet message recorder fm radio and more nokia 110 4g display tft lcd 1 8 65k colors cpu unisoc t107 ram 128 mb storage 48 mb battery 1020

**mở hộp đánh giá nhanh nokia 110 4g và nokia 105 4g youtube** - Mar 27 2022

web cùng so sánh nhanh 2 chiếc nokia mới của nhà nokia là 110 4g và 105 4g hai mẫu điện thoại phổ thông này có gì đặc biệt và khác nhau như thế nào nhé link mu

*nokia 110 4g ultimate guide of tips tricks r dumbphones reddit* - Mar 07 2023

web nov 22 2022 i bought the nokia 110 4g precisely because it was cheap and if it gets broken or lost we won t care do you know if there is any way to delete or disable the facebook app and or opera web browser on the phone

**nokia 110 4g review a solid feature phone nokiapoweruser** - Apr 08 2023

web oct 14 2021 it comes with a mini opera browser that works excellent for devices with a small screen readout mode which basically converts all written text to audio to aid those with poor visual acuity a

[nokia 110 opera renewalcc com](#) - May 29 2022

web nokia 110 opera downloaded from renewalcc com by guest gordon durham the games machines music opera dance and drama in asia the pacific and north americapc magpcmag com is a leading authority on technology delivering labs based independent reviews of the latest products and services our expert industry analysis

[how to download opera mini on nokia ccm](#) - Nov 03 2022

web mar 23 2022 how to download opera mini on nokia david webb 23 03 22 15 08 opera mini web browser is now available for nokia smartphones nokia phones can be configured for opera mini manually by creating a free prov setting this guide is applicable for nokia s60 series phones

*nokia 110 feature mobile phone* - Apr 27 2022

web nokia 110 features a solid modern design that fits perfectly in your hand capture the moment with the built in camera listen to news sports and entertainment on the go with the wireless fm radio or listen to your favorite tracks with the mp3 player

**the new nokia 110 with mp3 player** - Sep 13 2023

web nokia 110 with nokia 110 there s never a dull moment with the rear camera you re ready to capture life s best bits and with the built in mp3 player fm radio and games entertainment is always on hand it s all powered for days

**how can i download and install opera mini on nokia 110 ask me fast** - Jun 10 2023

web download opera mini 7 for nokia 110 i reset my nokia asha 302 and now the browser is not working and then if i try to download opera mini or uc browser and it says no certificate on unable to download anything in nokia n72 while using uc

**free download opera mini 7 1 for nokia 110 112 113 app** - Aug 12 2023

web opera mini 7 1 it is the newest version of opera mini published by asa softwares new and advanced features than the previous versions of opera mini better design and graphics with tabs now faster defend on the data that the network provides and beautiful for nokia 110 112 113 download app free

**nokia 110 full phone specifications gsmarena com** - Jul 11 2023

web nokia 110 released 2012 june 80g 14 5mm thickness feature phone 10mb storage microsdhc slot 0 1 2 941 505 hits 75 become a fan 1 8 128x160 pixels

nokia 110 4g 2023 reviewed stunning design updated features - Oct 02 2022

web jun 24 2023 the nokia 110 4g 2023 also retains all the essential features of its predecessor such as the wired wireless fm radio t9 dictionary input memory card support 3 5mm headphone input and opera

**nokia 110 4g takes on jioharat with upi payment and other** - Dec 04 2022

web jul 4 2023 nokia 110 4g and nokia 110 2g phones launched in india the nokia 4g phone arrives on the heels of the jioharat launch here are the nokia 110 4g price features and availability details

**frequently asked questions for opera mini for other platforms** - Jun 29 2022

web generally to change file permissions navigate to the folder where your opera mini app is located highlight opera mini and and select your phone s options or menu button look for application permission settings opera mini requires access to read and write user data and access to web connections if you cannot find these settings consult

*opera mini size nokia 110 opera mini orientation sutd edu sg* - Jul 31 2022

web opera mini size nokia 110 opera mini opera mini size nokia 110 opera mini simple groupware manual viewport sizes the best portable bluetooth speaker reviews by wirecutter case studies amp customer success amazon web services spy camera in delhi india best hidden wireless cameras online mobile browser id strings a k a user

*nokia 110 opera copy cyberlab sutd edu sg* - Feb 23 2022

web nokia 110 opera nomenclature of diseases apr 22 2022 reprint of the original opera singer journal gift for opera singer feb 06 2021 110 white pages college ruled notebook medium ruled matte cover this funny opera singer notebook is a great opera singer gift under 10 00 it is the perfect companion for any opera singer

**the new nokia 110 with mp3 player** - Sep 01 2022

web bertel jungin aukio 9 02600 espoo finland business id 2724044 2 with the built in mp3 player rear camera and more there is never a dull moment

nokia 110 with 4g camera and bluetooth - May 09 2023

web nokia 110 4g comes prepared with bluetooth connectivity a built in torch camera an opera mini internet browser and pre loaded games don t miss out sign up and be the first to get nokia phone news and offers