

## GETTING TO KNOW YOUR MACHINE

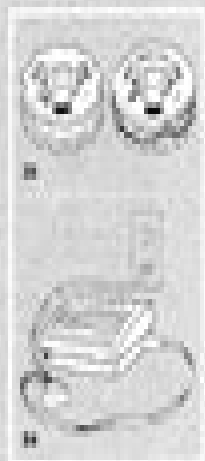
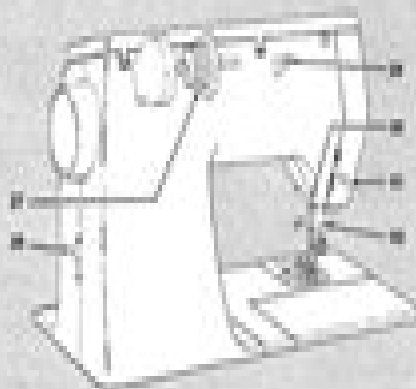
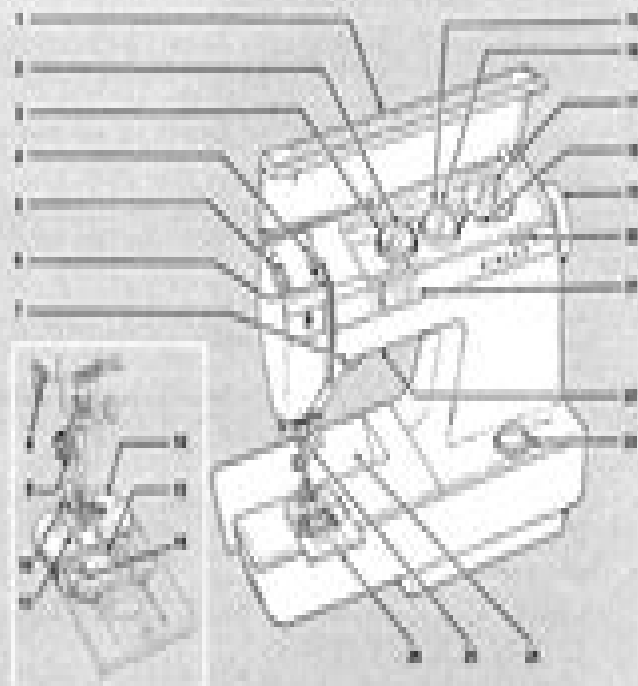

# Futura Ii Model 920 Manual

**Liong Bing Liem, Eugene Downar**

## **Futura Ii Model 920 Manual:**

**Progress in Catheter Ablation** Liong Bing Liem,Eugene Downar,2013-11-11 Catheter ablation is widely accepted as an effective and safe form of therapy for cardiac arrhythmia In many instances this curative procedure is considered as the first line of therapy if not the ultimate treatment of choice With the use of radiofrequency RF modality which has revolutionized the technology from a barotraumatic potentially injurious procedure using high voltage direct current DC shock to a safe and relatively painless one catheter ablation procedure now carries a very low risk and is extremely effective for certain types of arrhythmia Its efficacy rate in curing supraventricular tachycardia involving an accessory pathway or dual atrioventricular nodal pathways has been near perfect and its application for certain types of atrial and ventricular arrhythmia have also been very satisfactory However conventional RF ablation has several well known limitations most notably is its ability to only produce relatively small point lesions rendering it effective only for an arrhythmia with a small and or a superficial target It was soon recognized that the technology would not likely to have significant utility in arrhythmia with a more widespread target such as atrial fibrillation or those which involve scarred and deep myocardial tissue such as ventricular tachycardia Indeed the application of conventional RF technology in these complex but common arrhythmia has yielded unsatisfactory results *National Library of Medicine Current Catalog* National Library of Medicine (U.S.), **Subject Guide to Books in Print** ,1993 **Drugs and Driving** Herbert Moskowitz,2013-10-22 Drugs and Driving is a compendium of papers from a symposium of the same title presented at the U S Transportation Research Board This collection reviews the effects of five classes of drugs on driving amphetamines tranquilizers barbiturates narcotics cannabis the other studies being made on drugs and driving as well as some countermeasure programs against drunk driving The papers report that amphetamines can induce risky driving behavior tranquilizers can increase traffic accident risks barbiturates can degrade driving skills especially when the drug is combined with alcohol while marijuana use can impair important driving skills Another paper evaluates drug use and driving risk among high school students in Toronto results show that the total effect of infrequent use of drugs on accidents is small compared to alcohol use A study of out patients in Finland notes that the combined used of alcohol and drugs tend to increase accident frequency One paper refutes that Alcohol Safety Action Programs in the United States are ineffective This collection can be helpful for sociologist psychologists psychiatrists traffic safety officers and heads of urban safety and traffic divisions **National Union Catalog** ,1982 Includes entries for maps and atlases **National Union Catalog, 1982** ,1983 **Consumers Index to Product Evaluations and Information Sources** ,1980 Whitaker's Books of the Month and Books to Come ,1985 Library Journal ,1983 *Forthcoming Books* Rose Arny,2000

Eventually, you will no question discover a supplementary experience and talent by spending more cash. still when? do you say you will that you require to acquire those every needs bearing in mind having significantly cash? Why dont you attempt to get something basic in the beginning? Thats something that will lead you to understand even more nearly the globe, experience, some places, afterward history, amusement, and a lot more?

It is your unquestionably own become old to play reviewing habit. in the middle of guides you could enjoy now is **Futura Ii Model 920 Manual** below.

<https://staging.conocer.cide.edu/public/virtual-library/index.jsp/Name%20Something%20That%20People%20Pull%20Down.pdf>

## **Table of Contents Futura Ii Model 920 Manual**

1. Understanding the eBook Futura Ii Model 920 Manual
  - The Rise of Digital Reading Futura Ii Model 920 Manual
  - Advantages of eBooks Over Traditional Books
2. Identifying Futura Ii Model 920 Manual
  - Exploring Different Genres
  - Considering Fiction vs. Non-Fiction
  - Determining Your Reading Goals
3. Choosing the Right eBook Platform
  - Popular eBook Platforms
  - Features to Look for in an Futura Ii Model 920 Manual
  - User-Friendly Interface
4. Exploring eBook Recommendations from Futura Ii Model 920 Manual
  - Personalized Recommendations
  - Futura Ii Model 920 Manual User Reviews and Ratings
  - Futura Ii Model 920 Manual and Bestseller Lists

5. Accessing Futura Ii Model 920 Manual Free and Paid eBooks
  - Futura Ii Model 920 Manual Public Domain eBooks
  - Futura Ii Model 920 Manual eBook Subscription Services
  - Futura Ii Model 920 Manual Budget-Friendly Options
6. Navigating Futura Ii Model 920 Manual eBook Formats
  - ePub, PDF, MOBI, and More
  - Futura Ii Model 920 Manual Compatibility with Devices
  - Futura Ii Model 920 Manual Enhanced eBook Features
7. Enhancing Your Reading Experience
  - Adjustable Fonts and Text Sizes of Futura Ii Model 920 Manual
  - Highlighting and Note-Taking Futura Ii Model 920 Manual
  - Interactive Elements Futura Ii Model 920 Manual
8. Staying Engaged with Futura Ii Model 920 Manual
  - Joining Online Reading Communities
  - Participating in Virtual Book Clubs
  - Following Authors and Publishers Futura Ii Model 920 Manual
9. Balancing eBooks and Physical Books Futura Ii Model 920 Manual
  - Benefits of a Digital Library
  - Creating a Diverse Reading Collection Futura Ii Model 920 Manual
10. Overcoming Reading Challenges
  - Dealing with Digital Eye Strain
  - Minimizing Distractions
  - Managing Screen Time
11. Cultivating a Reading Routine Futura Ii Model 920 Manual
  - Setting Reading Goals Futura Ii Model 920 Manual
  - Carving Out Dedicated Reading Time
12. Sourcing Reliable Information of Futura Ii Model 920 Manual
  - Fact-Checking eBook Content of Futura Ii Model 920 Manual
  - Distinguishing Credible Sources
13. Promoting Lifelong Learning

- Utilizing eBooks for Skill Development
  - Exploring Educational eBooks
14. Embracing eBook Trends
- Integration of Multimedia Elements
  - Interactive and Gamified eBooks

### **Futura Ii Model 920 Manual Introduction**

Futura Ii Model 920 Manual Offers over 60,000 free eBooks, including many classics that are in the public domain. Open Library: Provides access to over 1 million free eBooks, including classic literature and contemporary works. Futura Ii Model 920 Manual Offers a vast collection of books, some of which are available for free as PDF downloads, particularly older books in the public domain. Futura Ii Model 920 Manual : This website hosts a vast collection of scientific articles, books, and textbooks. While it operates in a legal gray area due to copyright issues, its a popular resource for finding various publications. Internet Archive for Futura Ii Model 920 Manual : Has an extensive collection of digital content, including books, articles, videos, and more. It has a massive library of free downloadable books. Free-eBooks Futura Ii Model 920 Manual Offers a diverse range of free eBooks across various genres. Futura Ii Model 920 Manual Focuses mainly on educational books, textbooks, and business books. It offers free PDF downloads for educational purposes. Futura Ii Model 920 Manual Provides a large selection of free eBooks in different genres, which are available for download in various formats, including PDF. Finding specific Futura Ii Model 920 Manual, especially related to Futura Ii Model 920 Manual, might be challenging as theyre often artistic creations rather than practical blueprints. However, you can explore the following steps to search for or create your own Online Searches: Look for websites, forums, or blogs dedicated to Futura Ii Model 920 Manual, Sometimes enthusiasts share their designs or concepts in PDF format. Books and Magazines Some Futura Ii Model 920 Manual books or magazines might include. Look for these in online stores or libraries. Remember that while Futura Ii Model 920 Manual, sharing copyrighted material without permission is not legal. Always ensure youre either creating your own or obtaining them from legitimate sources that allow sharing and downloading. Library Check if your local library offers eBook lending services. Many libraries have digital catalogs where you can borrow Futura Ii Model 920 Manual eBooks for free, including popular titles. Online Retailers: Websites like Amazon, Google Books, or Apple Books often sell eBooks. Sometimes, authors or publishers offer promotions or free periods for certain books. Authors Website Occasionally, authors provide excerpts or short stories for free on their websites. While this might not be the Futura Ii Model 920 Manual full book , it can give you a taste of the authors writing style. Subscription Services Platforms like Kindle Unlimited or Scribd offer subscription-based access to a wide range of Futura Ii Model 920 Manual eBooks, including some popular titles.

## **FAQs About Futura Ii Model 920 Manual Books**

1. Where can I buy Futura Ii Model 920 Manual books? Bookstores: Physical bookstores like Barnes & Noble, Waterstones, and independent local stores. Online Retailers: Amazon, Book Depository, and various online bookstores offer a wide range of books in physical and digital formats.
2. What are the different book formats available? Hardcover: Sturdy and durable, usually more expensive. Paperback: Cheaper, lighter, and more portable than hardcovers. E-books: Digital books available for e-readers like Kindle or software like Apple Books, Kindle, and Google Play Books.
3. How do I choose a Futura Ii Model 920 Manual book to read? Genres: Consider the genre you enjoy (fiction, non-fiction, mystery, sci-fi, etc.). Recommendations: Ask friends, join book clubs, or explore online reviews and recommendations. Author: If you like a particular author, you might enjoy more of their work.
4. How do I take care of Futura Ii Model 920 Manual books? Storage: Keep them away from direct sunlight and in a dry environment. Handling: Avoid folding pages, use bookmarks, and handle them with clean hands. Cleaning: Gently dust the covers and pages occasionally.
5. Can I borrow books without buying them? Public Libraries: Local libraries offer a wide range of books for borrowing. Book Swaps: Community book exchanges or online platforms where people exchange books.
6. How can I track my reading progress or manage my book collection? Book Tracking Apps: Goodreads, LibraryThing, and Book Catalogue are popular apps for tracking your reading progress and managing book collections. Spreadsheets: You can create your own spreadsheet to track books read, ratings, and other details.
7. What are Futura Ii Model 920 Manual audiobooks, and where can I find them? Audiobooks: Audio recordings of books, perfect for listening while commuting or multitasking. Platforms: Audible, LibriVox, and Google Play Books offer a wide selection of audiobooks.
8. How do I support authors or the book industry? Buy Books: Purchase books from authors or independent bookstores. Reviews: Leave reviews on platforms like Goodreads or Amazon. Promotion: Share your favorite books on social media or recommend them to friends.
9. Are there book clubs or reading communities I can join? Local Clubs: Check for local book clubs in libraries or community centers. Online Communities: Platforms like Goodreads have virtual book clubs and discussion groups.
10. Can I read Futura Ii Model 920 Manual books for free? Public Domain Books: Many classic books are available for free as they're in the public domain. Free E-books: Some websites offer free e-books legally, like Project Gutenberg or Open Library.

**Find Futura Ii Model 920 Manual :**

~~name something that people pull down~~

[napa filter reference guide](#)

*napoleacuteron ier napoleacuteron iii bacircctisseurs*

**nasm manual corrective exercise**

[narcotics anonymous basic text audio 5th edition](#)

**namibie petit futeacute avec cartes photos avis des lecteurs**

[nada medium duty truck guide](#)

[n2 fitting and machining](#)

[nakajima wpt 160 typewriter manual](#)

**napa ship design tool manual**

~~nada guide book covers~~

**n2 maths memo**

~~nad m51 manual~~

**nadharia ya udenguzi kimaudhui**

[n2 fitting question papers with memos](#)

**Futura Ii Model 920 Manual :**

[sports injuries types treatments prevention and](#) - Mar 09 2023

web sports injuries prevention diagnosis treatment and rehabilitation home reference work editors mahmut nedim doral jon karlsson brings readers up to date on the

**sports rehabilitation and injury prevention wiley online books** - Jul 13 2023

web may 14 2010 it covers each stage of the rehabilitation process from initial assessment diagnosis and treatment to return to pre injury fitness and injury prevention

**sports injuries prevention treatment and rehabilitation** - Aug 02 2022

web in prevention of sport injuries as well as rehabilitation the primary focus of sports medicine professionals is on the physical aspects for example muscle strength and

**sports injuries types treatment and prevention** - Apr 10 2023

web a key factor in all sports injury rehabilitation protocols is injury prevention this involves data maintenance by teams or



trainers which is still not fully developed in the indian

**sports injuries prevention diagnosis treatment and** - Nov 05 2022

web written by three world renowned experts sports injuries fifth edition comprehensively covers the prevention treatment and rehabilitation of sports injuries essential

sports physiotherapist and preventive approaches in sports - Dec 26 2021

great challenges toward sports injury prevention and - Sep 03 2022

web jan 1 2021 pdf on jan 1 2021 gumusdag h published sports injuries prevention and treatment find read and cite all the research you need on researchgate

**current concepts in sports injury rehabilitation pmc** - Jan 07 2023

web apr 20 2023 the aims of this special issue are to i describe the extent of the injury problem in specific athlete populations including tactical athletes ii understand the

*advocating a holistic approach for sport injury prevention and* - Mar 29 2022

web imu department of physical therapy and rehabilitation focuses on the health care specialities meant to restore health and functional abilities for people after acute illness

sports injury wikipedia - Oct 24 2021

sports injuries prevention treatment and - Jul 01 2022

web mar 10 2020 elevation uses gravity to improve swelling by reducing blood flow to the injured area you should start using the r i c e method as soon as possible after an

**frontiers in sports and active living injury prevention and** - May 31 2022

web the work pays detailed attention to biomechanics and injury prevention examines the emerging treatment role of current strategies and evaluates sports injuries of each part

sports injury prevention and rehabilitation integrating medicine - May 11 2023

web the following are some basic steps to prevent a sports injury develop a fitness plan that includes cardiovascular exercise strength training and flexibility this will help decrease

**sports injury prevention and rehabilitation routledge** - Jun 12 2023

web dec 18 2015 sports injury prevention and rehabilitation is essential reading for any course in sports medicine and rehabilitation strength and conditioning sports

physical therapy and rehabilitation medipol university - Nov 24 2021

[preventing sports injuries johns hopkins medicine](#) - Feb 08 2023

web an up to date guide to the diagnosis and treatment of the full range of sports injuries pays detailed attention to biomechanics and injury prevention examines the emerging

**pdf sports injuries prevention and treatment researchgate** - Apr 29 2022

web ahpgs accreditation agency in health and social sciences sports physiotherapist and preventive approaches in sports injuries seminar 11 03 2021 thu 09 44

*special issue sports injury prevention and rehabilitation mdpi* - Oct 04 2022

web sep 4 2023 applied clinical and translational research across all fields of sport medicine and science which contribute to injury prevention or rehabilitation within the context of

**sports injuries prevention diagnosis treatment and rehabilitation** - Jan 27 2022

**sports injuries prevention and rehabilitation elsevier** - Aug 14 2023

web to address this issue this edition of jsbs features research on the prevention and rehabilitation of sports injuries it includes review and original research articles on ankle sprain injuries hamstring muscle strain injuries shoulder injuries in baseball pitching

**sports injuries prevention diagnosis treatment and** - Dec 06 2022

web jul 3 2020 what is the healing process injured tissue how can we optimize the process of healing functional recovery and safe return to sports

[sports injury prevention and treatment basics verywell fit](#) - Feb 25 2022

web player getting ankle taped at an american football game in mexico a tennis injury tackles like this one in women s australian rules football can cause injuries ryan miller of the

**p1375 1 fg wilson** - May 05 2022

web generator set specifications minimum rating 1250 kva 1000 kw maximum rating 1375 kva 1100 kw emissions fuel strategy fuel optimised 50 hz prime 1250 kva 1000 kw

[p165 6 150 kva to 165 kva diesel generator fg wilson](#) - Oct 22 2023

web proven in the field the p165 6 150 kva to 165 kva diesel generator is capable of providing reliable power for a wide range of prime and standby applications

*fg wilson engineering ltd diesel generator set p165 1* - Mar 15 2023

web fg wilson engineering ltd diesel generator set p165 1 fg wilson engineering ltd description fg wilson provides a range of diesel generator set models typically used for power in offices shops clinics and for domestic purposes

[fg wilson xp165e1 by power generation issuu](#) - Jun 18 2023

[web jul 23 2013 fg wilson xp165e1 spare parts catalogue perkins engine serial number dealer contact details date of print 3 29 2010 table of content description perkins engine short long engine page 6 8](#)

**genset fg wilson p165 1 wilson engineering indonetwork co id** - Sep 09 2022

[web pt fajar gemilang wilson engineering lokasi kota administrasi jakarta barat bergabung selama bagikan katalog produk informasi perusahaan bagikan kontak kami genset fg wilson p165 1 kontak kami genset fg wilson p165 1](#)

[fg wilson p165e1 for sale generator set 4367512 truck1](#) - Jan 13 2023

[web generator set fg wilson p165e1 in united kingdom for sale manufacture year 2014 truck1 id 4367512 stay up to date with our offerings](#)

**p165 6 1 fg wilson** - Feb 14 2023

[web fg wilson genuine parts warranty global facilities news events contact us find dealer request a quote login p165 6 1 home p165 6 1 download premium wordpress themes free download wordpress themes download wordpress themes download wordpress themes free download udemy paid course for free](#)

[fg wilson xp165e1 orientation sutd edu sg](#) - Oct 10 2022

[web fg wilson xp165e1 by power generation issuu march 24th 2018 issuu is a digital publishing platform that makes it simple to publish magazines catalogs newspapers books and more online easily share your publications and get them in front of issuu s millions of monthly readers](#)

**p1000 1 fg wilson** - Apr 04 2022

[web generator set specifications minimum rating 910 kva 728 kw maximum rating 1000 kva 800 kw emissions fuel strategy fuel optimised 50 hz prime 730 kva 584 kw](#)

[fg wilson p165 pdf scribd](#) - Dec 12 2022

[web fg wilson p165 read online for free scribd is the world s largest social reading and publishing site open navigation menu close suggestions search search en change language close menu language english selected](#)

**fg wilson generator manufacturer power generator company fg wilson** - May 17 2023

[web find inventory near you with fg wilson power centre fg wilson generators is a leading global provider and generator manufacturer of prime power and back up diesel power generators built in modern facilities across the globe](#)

**p16 1 14 5 kva to 16 kva diesel generator fg wilson** - Jun 06 2022

[web proven in the field the p16 1 14 5 kva to 16 kva diesel generator is capable of providing reliable power for a wide range of prime and standby applications](#)

**p165 3 165 kva open generator set fg wilson** - Apr 16 2023

web p165 3 image for illustration purposes only output ratings ratings and performance data voltage frequency engine make model alternator manufactured for fg wilson by alternator model ratings at 0.8 power factor control panel please refer to the output ratings technical data section for specific generator set outputs per voltage

[p165 6 fg wilson](#) - Jul 19 2023

web p165 6 minimum rating 150 kva 120 kw maximum rating 165 0 kva 132 0 kw emissions fuel strategy eu stage iiiia emissions compliant request a quote

**p1650 1 fg wilson** - Sep 21 2023

web the fg wilson powerwizard range of digital control panels combine straightforward menu navigation with advanced metering and protection technology they are used in automatic mains failure applications in conjunction with transfer panels  
*fg wilson xp65e1 by power generation issuu* - Nov 11 2022

web jul 24 2013 fg wilson xp65e1 published on jul 24 2013 power generation follow this publisher about spare parts catalogue perkins engine more from power generation perkins engine ws5410 1300 series

**home fg wilson** - Aug 20 2023

web our product range from 6.8 2 500 kva includes open and enclosed generator sets providing prime and standby power from standby domestic use right up to power modules with the ability to operate as complete power stations

**fg wilson xp165e1 subsites imoney my** - Mar 03 2022

web generating sets xp27 xp165e1 fg wilson engineering ltd uk ver 01 feb 05 catálogo de peças fg wilson compass genesis 2014 por r 258 76 april 17th 2018 este diretório eletrônico é o catálogo de peças de reposição e acessórios para motores a  
[fg wilson xp165e1](#) - Jul 07 2022

web fg wilson xp165e1 by power generation issuu march 24th 2018 issuu is a digital publishing platform that makes it simple to publish magazines catalogs newspapers books and more online easily share your publications and get them in front of issuu s millions of monthly readers fg wilson fg wilson

**p165 5 fg wilson** - Aug 08 2022

web these ratings are applicable for supplying continuous electrical power at variable load in lieu of commercially purchased power there is no limitation to the annual hours of operation and this model can supply 10 overload power for 1 hour in 12 hours 60 hz prime rating

**daily geography practice grade 4 teacher s edition print** - Apr 11 2023

web in daily geography practice grade 4 36 map lessons introduce basic geography skills and over 100 geography terms with a fun hands on approach to geography instruction lessons are designed to support any geography

**daily geography practice grade 4 overdrive** - Apr 30 2022

web jun 1 2004 daily geography practice grade 4 ebook daily geography practice by evan moor educational publishers format ebook series daily geography practice author evan moor educational publishers publisher evan moor corporation release 01 june 2004 subjects juvenile nonfiction science find this title in libby the library reading app by

*daily geography practice grade 4 emc 3713 google books* - Feb 09 2023

web in daily geography practice grade 4 36 map lessons introduce basic geography skills and over 100 geography terms what a perfect hands on approach to geography instruction the

**daily geography practice grade 4 emc 3713 mitpressbookstore** - Dec 07 2022

web aug 1 2004 in daily geography practice grade 4 36 map lessons introduce basic geography skills and over 100 geography terms what a perfect hands on approach to geography instruction the geography skills presented at grade 4 include globes compass roses map legends map grids and coordinates map scales physical state

daily geography practice grade 4 student workbook - May 12 2023

web in daily geography practice grade 4 36 map lessons introduce basic geography skills and over 100 geography terms what a perfect hands on approach to geography instruction the geography skills presented at grade 4 include globes compass roses map legends map grids and coordinates map scales physical state region and country

**daily geography practice grade 4 emc 3713 kağıt kapak** - Jun 13 2023

web daily geography practice grade 4 emc 3713 evan moor educational publishers amazon com tr kitap

daily geography practice grade 4 softcover abebooks - Oct 05 2022

web explore the globe with your fourth graders through evan moor s daily geography practice the grade four print teacher s edition offers 36 map lessons introducing students to a wealth of geography skills and more than 100 vital geography terms through this hands on approach your fourth graders will become astute globe travelers learning all

daily geography practice workbook gr 4 lakeshore - Jun 01 2022

web daily geography practice workbook gr 4 29 99 qty add to cart add to registry add to shopping list ship item store pickup only not eligible to ship store pickup in stock at carson ca in store curbside pickup available recommended age 9 yrs

*daily geography practice grade 4 teacher s edition e book* - Jul 14 2023

web grade 4 reproducible teacher s edition standard e book you can teach geography daily geography practice contains quick 15 minute lessons that help students become geographically literate each of the 36 weekly lessons is correlated to the national geography standards six essential elements

daily geography practice 5 book series kindle edition - Aug 03 2022

web in daily geography practice grade 4 36 map lessons introduce basic geography skills and over 100 geography terms what a perfect hands on approach to geography instruction the geography skills presented at grade 4 include globes compass

roses map legends map grids and coordinates map scales physical state region and country maps

[daily geography practice grade 4 goodreads](#) - Sep 04 2022

web daily geography practice grade 4 by evan moor educational publishers goodreads jump to ratings and reviews want to read buy on amazon rate this book daily geography practice grade 4 evan moor educational publishers 3 67 9 ratings0 reviews explore the globe with your fourth graders through evan moor s daily geography practice

**daily geography practice grade 4 weeks 25 30 tpt** - Jul 02 2022

web a 10 page reproducible geography glossary is included for students to use as an easy reference booklet throughout the year the weekly units in daily geography practice grade 4 weeks 25 30 cover these topics week 25 climate zones of the united states week 26 the amazon rainforest

**daily geography practice grade 4 emc 3713 best sellers rank** - Dec 27 2021

web apr 9 2019 what a perfect hands on approach to geography instruction the geography skills presented at grade 4 include globes compass roses map legends map grids and coordinates map scales physical state region and country maps projections road and tourist maps historical and cultural landmark maps population and product maps climate

**daily geography practice grade 4 amazon com** - Aug 15 2023

web jun 1 2004 explore the globe with your fourth graders through evan moor s daily geography practice the grade four print teacher s edition offers 36 map lessons introducing students to a wealth of geography skills

[daily geography practice grade 4 amazon ca](#) - Nov 06 2022

web jun 1 2004 in this daily geography 4 your student will learn about hemispheres latitude and longitude physical and political maps time zones and even a little history on the 13 original colonies there are 5 lessons per week monday thru friday with each day having 2 questions that require a written answer

**daily geography practice grade 4 student book goodreads** - Jan 08 2023

web dec 1 2005 the student edition offers an alternative to photocopying the reproducible student pages found in the teacher s edition in daily geography practice grade 4 36 map lessons introduce basic geography skills and over 100 geography terms what a perfect hands on approach to geography instruction

**daily geography practice grade 4 student workbook christianbook com** - Feb 26 2022

web product description provide students the convenience of their own workbook with daily geography practice student workbook grade 4 from evan moor this student edition corresponds to the sold separately daily geography practice teacher edition grade 3

[daily geography practice series rainbow resource](#) - Mar 30 2022

web item 033534 grades 1 retail 29 99 our price 19 90 add to cart daily geography practice grade 1 individual student

workbook item 076888 grades 1 retail 8 99 our price 5 95 add to cart daily geography practice gr 2 item 033535 grades 2 retail 29 99 our price 19 90 add to cart

daily geography practice grade 4 christianbook com - Mar 10 2023

web challenge questions are included and often need to be independently researched daily geography practice looks at the world in spatial terms places and regions physical systems human systems environment and society and uses of geography 160 reproducible pages softcover grade 4

**180 days of social studies grade 4 daily geography** - Jan 28 2022

web mar 1 2018 180 days of geography practice workbook 4th grade daily activities for the entire year 216 pages the 180 days of geography workbook offers daily practice with engaging activities and lessons 4th grade students use for the entire school year