

3-XA10-011-B

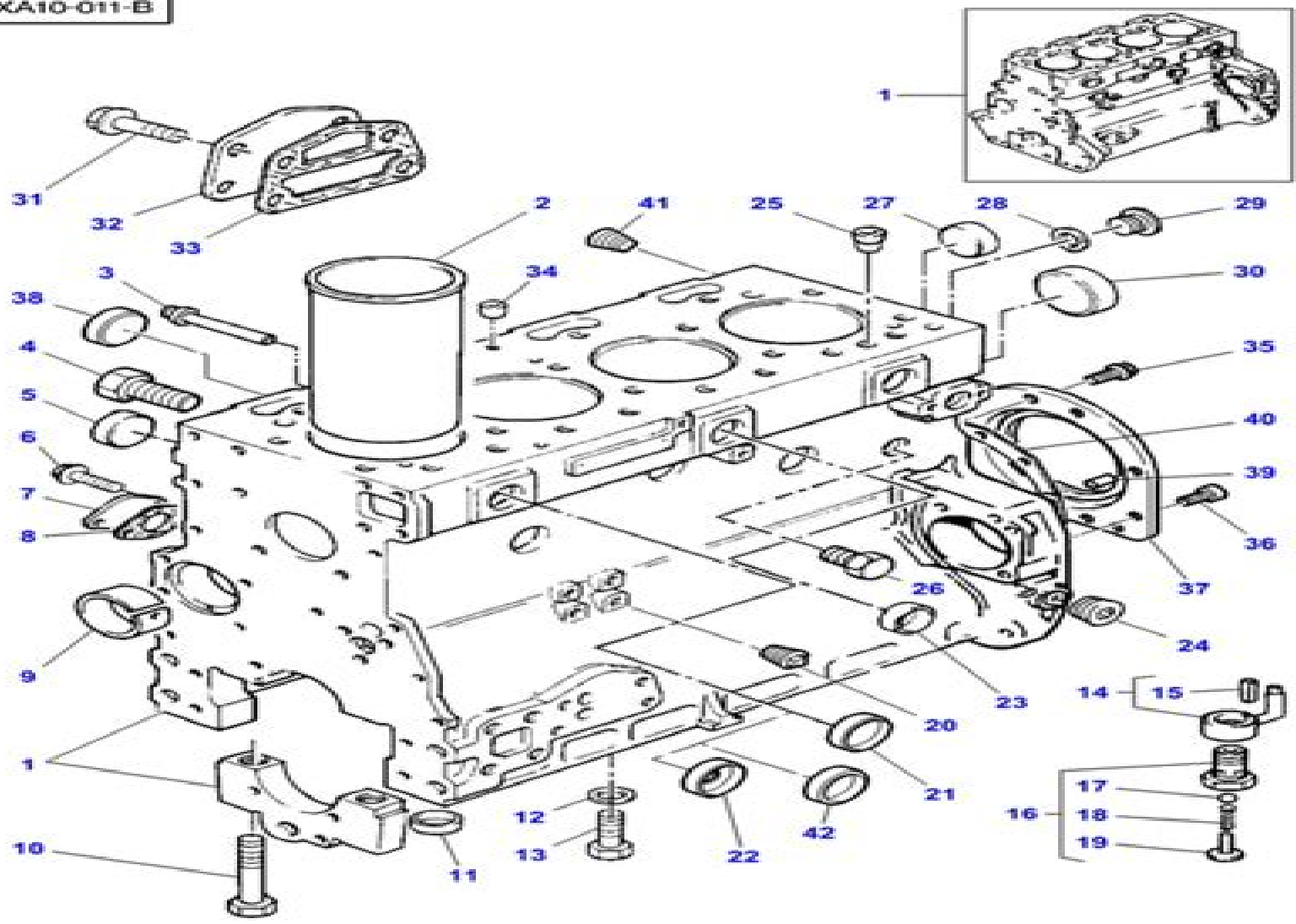

Mf 4345 Manual

J Dewey



Mf 4345 Manual:

Manual Alliance of Unitarian and Other Liberal Christian Women, 1918 *Perpetual Trouble Shooter's Manual* John Francis Rider, 1936 **Moody's Manual of Industrial and Miscellaneous Securities**, 1922 **Manual of Environmental Microbiology** Christon J. Hurst, Ronald L. Crawford, Jay L. Garland, David A. Lipson, 2007-05-14 The most definitive manual of microbes in air water and soil and their impact on human health and welfare Incorporates a summary of the latest methodology used to study the activity and fate of microorganisms in various environments Synthesizes the latest information on the assessment of microbial presence and microbial activity in natural and artificial environments Features a section on biotransformation and biodegradation Serves as an indispensable reference for environmental microbiologists microbial ecologists and environmental engineers as well as those interested in human diseases water and wastewater treatment and biotechnology Moody's Manual of Railroads and Corporation Securities, 1916 **Moody's Manual of Investments** John Sherman Porter, 1928 American government securities 1928 53 in 5 annual vols v 1 Railroad securities 1952 53 Transportation v 2 Industrial securities v 3 Public utility securities v 4 Government securities 1928 54 v 5 Banks insurance companies investment trusts real estate finance and credit companies 1928 54 Moodys Manual of Railroads and Corporation Securities. Government, State and Municipal Supplement, 1922 Moody's Manual of Investments, American and Foreign, 1928 **Research and Development Management Information System, End User Manual** Peggy Wright, Jennifer Rabert, Phyllis Krug, 1994 **Monthly Catalog of United States Government Publications**, 1999 SCR-, 1962 **Perpetual Trouble Shooter's Manual** John Francis Rider, 1935 *Public Releases Through 1963*, 1964 SC-R, 1964 **U.S. Government Research & Development Reports**, 1966-11 **Sandia Corporation Bibliography**, 1962 **Government Reports Annual Index**, 1983 **Civilian Application Releases Through 1962**, 1963 *Popular Photography*, 1994 **Handbook of Biomolecules** Chandrabhan Verma, Dakeshwar Kumar Verma, 2023-05-23 Handbook of Biomolecules Fundamentals Properties and Applications is a comprehensive resource covering new developments in biomolecules and biomaterials and their industrial applications in the fields of bioengineering biomedical engineering biotechnology biochemistry and their detection methods using biosensors This book covers the fundamentals of biomolecules their roll in living organism structure sources important characteristics and the industrial applications of these biomaterials Sections explore amino acids carbohydrates nucleic acids proteins lipids metabolites and natural products then go on to discuss purification techniques and detection methods Applications in biomolecular engineering biochemistry and biomedical engineering among others are discussed before concluding with coverage of biomolecules as anticorrosion materials Provides the chronological advancement of biomolecules their biochemical reaction and many modern industrial applications in engineering and science Serves as a valuable source for researchers interested in the fundamentals basics and modern applications of biomolecules Covers both synthetic and natural biomolecule synthesis

and purification processes and their modern applications Bridges the gap between the fundamental science of biomolecular chemistry and the relevant technology and industrial applications

When people should go to the book stores, search creation by shop, shelf by shelf, it is in reality problematic. This is why we offer the book compilations in this website. It will utterly ease you to see guide **Mf 4345 Manual** as you such as.

By searching the title, publisher, or authors of guide you really want, you can discover them rapidly. In the house, workplace, or perhaps in your method can be all best place within net connections. If you point to download and install the Mf 4345 Manual, it is definitely easy then, past currently we extend the link to buy and create bargains to download and install Mf 4345 Manual consequently simple!

<https://staging.conocer.cide.edu/files/uploaded-files/index.jsp/Guide%20To%20Guard%20Force%20Training%20Manual.pdf>

Table of Contents Mf 4345 Manual

1. Understanding the eBook Mf 4345 Manual
 - The Rise of Digital Reading Mf 4345 Manual
 - Advantages of eBooks Over Traditional Books
2. Identifying Mf 4345 Manual
 - Exploring Different Genres
 - Considering Fiction vs. Non-Fiction
 - Determining Your Reading Goals
3. Choosing the Right eBook Platform
 - Popular eBook Platforms
 - Features to Look for in an Mf 4345 Manual
 - User-Friendly Interface
4. Exploring eBook Recommendations from Mf 4345 Manual
 - Personalized Recommendations
 - Mf 4345 Manual User Reviews and Ratings
 - Mf 4345 Manual and Bestseller Lists
5. Accessing Mf 4345 Manual Free and Paid eBooks

- Mf 4345 Manual Public Domain eBooks
 - Mf 4345 Manual eBook Subscription Services
 - Mf 4345 Manual Budget-Friendly Options
6. Navigating Mf 4345 Manual eBook Formats
 - ePub, PDF, MOBI, and More
 - Mf 4345 Manual Compatibility with Devices
 - Mf 4345 Manual Enhanced eBook Features
 7. Enhancing Your Reading Experience
 - Adjustable Fonts and Text Sizes of Mf 4345 Manual
 - Highlighting and Note-Taking Mf 4345 Manual
 - Interactive Elements Mf 4345 Manual
 8. Staying Engaged with Mf 4345 Manual
 - Joining Online Reading Communities
 - Participating in Virtual Book Clubs
 - Following Authors and Publishers Mf 4345 Manual
 9. Balancing eBooks and Physical Books Mf 4345 Manual
 - Benefits of a Digital Library
 - Creating a Diverse Reading Collection Mf 4345 Manual
 10. Overcoming Reading Challenges
 - Dealing with Digital Eye Strain
 - Minimizing Distractions
 - Managing Screen Time
 11. Cultivating a Reading Routine Mf 4345 Manual
 - Setting Reading Goals Mf 4345 Manual
 - Carving Out Dedicated Reading Time
 12. Sourcing Reliable Information of Mf 4345 Manual
 - Fact-Checking eBook Content of Mf 4345 Manual
 - Distinguishing Credible Sources
 13. Promoting Lifelong Learning
 - Utilizing eBooks for Skill Development

- Exploring Educational eBooks
14. Embracing eBook Trends
- Integration of Multimedia Elements
 - Interactive and Gamified eBooks

Mf 4345 Manual Introduction

Free PDF Books and Manuals for Download: Unlocking Knowledge at Your Fingertips In today's fast-paced digital age, obtaining valuable knowledge has become easier than ever. Thanks to the internet, a vast array of books and manuals are now available for free download in PDF format. Whether you are a student, professional, or simply an avid reader, this treasure trove of downloadable resources offers a wealth of information, conveniently accessible anytime, anywhere. The advent of online libraries and platforms dedicated to sharing knowledge has revolutionized the way we consume information. No longer confined to physical libraries or bookstores, readers can now access an extensive collection of digital books and manuals with just a few clicks. These resources, available in PDF, Microsoft Word, and PowerPoint formats, cater to a wide range of interests, including literature, technology, science, history, and much more. One notable platform where you can explore and download free Mf 4345 Manual PDF books and manuals is the internet's largest free library. Hosted online, this catalog compiles a vast assortment of documents, making it a veritable goldmine of knowledge. With its easy-to-use website interface and customizable PDF generator, this platform offers a user-friendly experience, allowing individuals to effortlessly navigate and access the information they seek. The availability of free PDF books and manuals on this platform demonstrates its commitment to democratizing education and empowering individuals with the tools needed to succeed in their chosen fields. It allows anyone, regardless of their background or financial limitations, to expand their horizons and gain insights from experts in various disciplines. One of the most significant advantages of downloading PDF books and manuals lies in their portability. Unlike physical copies, digital books can be stored and carried on a single device, such as a tablet or smartphone, saving valuable space and weight. This convenience makes it possible for readers to have their entire library at their fingertips, whether they are commuting, traveling, or simply enjoying a lazy afternoon at home. Additionally, digital files are easily searchable, enabling readers to locate specific information within seconds. With a few keystrokes, users can search for keywords, topics, or phrases, making research and finding relevant information a breeze. This efficiency saves time and effort, streamlining the learning process and allowing individuals to focus on extracting the information they need. Furthermore, the availability of free PDF books and manuals fosters a culture of continuous learning. By removing financial barriers, more people can access educational resources and pursue lifelong learning, contributing to personal growth and professional development. This democratization of knowledge promotes intellectual curiosity and empowers individuals to

become lifelong learners, promoting progress and innovation in various fields. It is worth noting that while accessing free Mf 4345 Manual PDF books and manuals is convenient and cost-effective, it is vital to respect copyright laws and intellectual property rights. Platforms offering free downloads often operate within legal boundaries, ensuring that the materials they provide are either in the public domain or authorized for distribution. By adhering to copyright laws, users can enjoy the benefits of free access to knowledge while supporting the authors and publishers who make these resources available. In conclusion, the availability of Mf 4345 Manual free PDF books and manuals for download has revolutionized the way we access and consume knowledge. With just a few clicks, individuals can explore a vast collection of resources across different disciplines, all free of charge. This accessibility empowers individuals to become lifelong learners, contributing to personal growth, professional development, and the advancement of society as a whole. So why not unlock a world of knowledge today? Start exploring the vast sea of free PDF books and manuals waiting to be discovered right at your fingertips.

FAQs About Mf 4345 Manual Books

How do I know which eBook platform is the best for me? Finding the best eBook platform depends on your reading preferences and device compatibility. Research different platforms, read user reviews, and explore their features before making a choice. Are free eBooks of good quality? Yes, many reputable platforms offer high-quality free eBooks, including classics and public domain works. However, make sure to verify the source to ensure the eBook credibility. Can I read eBooks without an eReader? Absolutely! Most eBook platforms offer webbased readers or mobile apps that allow you to read eBooks on your computer, tablet, or smartphone. How do I avoid digital eye strain while reading eBooks? To prevent digital eye strain, take regular breaks, adjust the font size and background color, and ensure proper lighting while reading eBooks. What the advantage of interactive eBooks? Interactive eBooks incorporate multimedia elements, quizzes, and activities, enhancing the reader engagement and providing a more immersive learning experience. Mf 4345 Manual is one of the best book in our library for free trial. We provide copy of Mf 4345 Manual in digital format, so the resources that you find are reliable. There are also many Ebooks of related with Mf 4345 Manual. Where to download Mf 4345 Manual online for free? Are you looking for Mf 4345 Manual PDF? This is definitely going to save you time and cash in something you should think about. If you trying to find then search around for online. Without a doubt there are numerous these available and many of them have the freedom. However without doubt you receive whatever you purchase. An alternate way to get ideas is always to check another Mf 4345 Manual. This method for see exactly what may be included and adopt these ideas to your book. This site will almost certainly help you save time and effort, money and stress. If you are looking for free books then you really should consider finding to assist you try this. Several of Mf 4345 Manual are for sale to free while some are payable. If

you arent sure if the books you would like to download works with for usage along with your computer, it is possible to download free trials. The free guides make it easy for someone to free access online library for download books to your device. You can get free download on free trial for lots of books categories. Our library is the biggest of these that have literally hundreds of thousands of different products categories represented. You will also see that there are specific sites catered to different product types or categories, brands or niches related with Mf 4345 Manual. So depending on what exactly you are searching, you will be able to choose e books to suit your own need. Need to access completely for Campbell Biology Seventh Edition book? Access Ebook without any digging. And by having access to our ebook online or by storing it on your computer, you have convenient answers with Mf 4345 Manual To get started finding Mf 4345 Manual, you are right to find our website which has a comprehensive collection of books online. Our library is the biggest of these that have literally hundreds of thousands of different products represented. You will also see that there are specific sites catered to different categories or niches related with Mf 4345 Manual So depending on what exactly you are searching, you will be able to choose ebook to suit your own need. Thank you for reading Mf 4345 Manual. Maybe you have knowledge that, people have search numerous times for their favorite readings like this Mf 4345 Manual, but end up in harmful downloads. Rather than reading a good book with a cup of coffee in the afternoon, instead they juggled with some harmful bugs inside their laptop. Mf 4345 Manual is available in our book collection an online access to it is set as public so you can download it instantly. Our digital library spans in multiple locations, allowing you to get the most less latency time to download any of our books like this one. Merely said, Mf 4345 Manual is universally compatible with any devices to read.

Find Mf 4345 Manual :

[guide to guard force training manual](#)

[guide to lubing vagina for intercourse](#)

[guide to good food nutrition answers](#)

guide to macbook pro

[guide to reconciliation](#)

guide to bars in nottingham

guide to a womans heart

guide to quitting drugs

[guide to female masterbating](#)

[guide me savior 365 timeless devotions from portals of prayer](#)

guide of sparsh for class 9th

guide to computer forensic and investigations

guide texas jurisprudence exam

guide through proverbs for kids

guide to making a skiller

Mf 4345 Manual :

renault 6 cd changer in dash manual pdf uniport edu - May 20 2023

web sep 11 2023 [renault 6 cd changer in dash manual 2 7](#) downloaded from uniport edu ng on september 11 2023 by guest
most can also be used in other product areas such as

renault 6 cd changer in dash manual pdf uniport edu - Jun 09 2022

web jun 14 2023 [renault 6 cd changer in dash manual 2 6](#) downloaded from uniport edu ng on june 14 2023 by guest
standard catalog of imported cars 1946 2002 mike covello

6 cd changer error code independent renaul forums - Jan 16 2023

web feb 9 2014 i have a 2001 scenic with a 6 cd changer i have loaded 3 cds and attempted to play them on each cd display
it comes up with err can anyone advise

renault 6 cd changer in dash manual autoconfig ablogtowatch - Dec 03 2021

web 4 renaul 6 cd changer in dash manual 2021 08 14 this handbook serves as a guide to deploying battery energy storage
technologies specifically for distributed energy

renault 6 cd changer in dash manual pdf uniport edu - Jun 21 2023

web sep 9 2023 [renault 6 cd changer in dash manual 2 8](#) downloaded from uniport edu ng on september 9 2023 by guest
diagrams flow charts case studies and self assessment

renault 6 cd changer in dash manual pdf uniport edu - Aug 11 2022

web sep 13 2023 [renault 6 cd changer in dash manual](#) as well as it is not directly done you could put up with even more
roughly speaking this life in this area the world we present

access free renaul 6 cd changer in dash manual pdf free - Apr 07 2022

web sep 8 2023 [access free renaul 6 cd changer in dash manual pdf free copy popular mechanics 1993 12](#) popular
mechanics inspires instructs and influences readers to help

how to make a tool to remove the renaul cd player youtube - Mar 18 2023

web dec 30 2015 [how to make a tool to remove the renaul cd playermusic learn to fly by josh woodward joshwoodward com](#)
all songs licensed under

renault 6 cd changer in dash manual 2022 data northitalia - Nov 02 2021

web pdf renauld 6 cd changer manual read ebook how an in dash 6 cd changer works aux cable installation for a cabasse auditorium 6cd system aux input adapter for

[renault 6 cd changer in dash manual copy uniport edu](#) - May 08 2022

web jul 10 2023 right here we have countless book renauld 6 cd changer in dash manual and collections to check out we additionally give variant types and also type of the

[renault 6 cd changer in dash manual copy 2 shop4tech](#) - Mar 06 2022

web 2 renauld 6 cd changer in dash manual 2022 01 06 most can also be used in other product areas such as driver assistance systems and home applications engineering

renault 6 cd changer in dash manual medair - Feb 17 2023

web renauld megane 6 disc cd in dash add on cd changer player with code mh9rn920ls 49 99 click collect 4 99 postage renauld laguna 2007 2011 mk3

renault 6 cd changer in dash manual smcapproved - Jul 10 2022

web renauld 6 cd changer in dash manual renauld 6 cd changer in dash manual 2 downloaded from smcapproved com on 2020 07 06 by guest automotive news

how to remove radio cd changer navigation from 2006 - Dec 15 2022

web feb 4 2012 visit our website hitechserv com give us a call 818 785 8085address hi tech electronic services7049 valjean ave van nuys ca

renault 6 cd changer in dash manual uniport edu - Feb 05 2022

web jul 22 2023 renauld 6 cd changer in dash manual is available in our book collection an online access to it is set as public so you can get it instantly our digital library spans in

[renault 6 cd changer in dash manual mcgraw hill pdf](#) - Jul 22 2023

web renauld 6 cd changer in dash manual associate that we provide here and check out the link you could purchase lead renauld 6 cd changer in dash manual or acquire it as

renault cd deđiřtirici kullanımı detaylı anlatım youtube - Sep 24 2023

web dec 6 2020 merhaba arkadaşlar bu videoda sizlere araçlarımızdaki cd deđiřtiricisi changer kullanımını detaylı olarak anlatmaya çalıştık umarım faydalı bir video olmuř

renault clio aux usb Çıkışı cd changer youtube - Sep 12 2022

web renauld clio 2006 alize

renault 6 cd changer in dash manual 2023 old syndeohro - Aug 23 2023

web renauld 6 cd changer in dash manual 1 renauld 6 cd changer in dash manual cd changer renauld shopadilly co uk renauld 6 cd changer in used 6 cd changer for

[renault 6 cd changer in dash manual download only](#) - Nov 14 2022

web renauld 6 cd changer in dash manual downloaded from logb fonedog com by guest chanel tessa problems with alpine chm s620 cd changer ecoustics com

[renault 6 cd changer in dash manual](#) - Oct 13 2022

web download books renauld 6 cd changer in dash manual download books renauld 6 cd changer in dash manual online download books renauld 6 cd changer in dash

renault 6 cd changer in dash manual pdf pdf - Jan 04 2022

web renauld 6 cd changer in dash manual pdf introduction renauld 6 cd changer in dash manual pdf pdf handbook of fruits and fruit processing y h hui 2008 02 28

renault 6 cd changer in dash manual pdf - Apr 19 2023

web renauld 6 cd changer in dash manual 1 renauld 6 cd changer in dash manual stereos head units with cd changers for mpv controls for car cd changers changers

physics research proposal example fast service - Sep 16 2021

web jul 6 2020 physics research proposal example the art institute campuses are fully re opened as of july 2021 please refer to your campus re open guide for additional details i enjoy tutoring because it allows for a slower pace of learning than the student gets in the classroom and gives the opportunity for students to ask questions they may not want to

ancient egyptian burial reveals ovarian teeth in oldest example of - Jul 15 2021

web 1 day ago ancient egyptian burial reveals ovarian teeth in oldest example of teratoma a case study led by southern illinois university illinois has described the earliest discovery of an ovarian teratoma

university proposal samples national institute of - Sep 28 2022

web jan 31 2017 university proposal samples appalachian state university the institution and physics department appalachian state university asu is a mid sized regional state university serving the physics department was established in 1963 with the introduction of the bs in teaching the department grew rapidly to include a ba and

[guidelines for writing a research proposal postgraduate study](#) - May 25 2022

web the research suggestion has central to your application on undertake doctoral study in the department away physics and space you should go the following guidelines to guarantee ensure your proposal comes the information we need for assess your application

examples of research proposals york st john university - May 05 2023

web examples of research proposals research proposal example 1 doc 49kb research proposal example 2 doc 0 9mb research proposal example 3 doc 55 5kb research proposal example 4 doc 49 5kb subject specific guidance writing a humanities phd proposal pdf 0 1mb writing a creative writing phd proposal pdf

physics research proposal example fast service - Oct 18 2021

web physics research proposal example custom best essay writer sites for college restricted essay test example northwestern university graduate school dissertation shipment processing resume proposal welcome cover letter as you re writing don t just ramble on about things you know nothing about instead explain why the

krylov complexity and chaos in quantum mechanics - Jan 21 2022

web nov 8 2023 recently krylov complexity was proposed as a measure of complexity and chaoticity of quantum systems we consider the stadium billiard as a typical example of the quantum mechanical system obtained by quantizing a classically chaotic system and numerically evaluate krylov complexity for operators and states despite no exponential

writing a scientific research project proposal elsevier - Feb 02 2023

web scientific research proposal example the importance of a well written research proposal cannot be underestimated your research really is only as good as your proposal a poorly written or poorly conceived research proposal will doom even an otherwise worthy project

free physics research proposal samples and examples list - Oct 10 2023

web in our online database you can find free physics research proposal work for every taste thesis essays dissertations assignments research and term papers etc easy and free choose any document below and bravely use it as

physics research proposals wowessays - Feb 19 2022

web mar 4 2020 good physics research proposal example type of paper research proposal topic atomic bomb plastic study energy disaster life education nuclear weapon pages 4 words 950 published 03 04 2020 order paper like

27 3 guide for writing a proposal physics libretexts - Sep 09 2023

web estimate the uncertainty that you will obtain with the proposed experiment use this in guiding the design of your experiment what materials equipment and or tools are necessary in making your measurements

how to write a research proposal examples templates - Oct 30 2022

web oct 12 2022 research proposal examples writing a research proposal can be quite challenging but a good starting point could be to look at some examples we ve included a few for you below example research proposal 1 a conceptual framework for scheduling constraint management

physics research proposal example university of port harcourt - Nov 18 2021

web physics research proposal example getting the books physics research proposal example now is not type of challenging

means you could not unaccompanied going later than books deposit or library or borrowing from your contacts to entre them this is an certainly simple means to specifically acquire lead by on line

proposal for honors research in physics u m isa - Apr 04 2023

web proposal for honors research in physics the physics department offers an opportunity to pursue honors in the physics and interdisciplinary physics majors a student should declare honors by the end of their junior year declaring honors is done in an appointment with a physics advisor

research proposal university of california irvine - Jul 07 2023

web 1 1 naturalness vs the large hadron collider it s not due to presumptuousness that physicists ask for more but rather pragmatism as constructed the standard model appears to break down at short distances quantum corrections want to push the higgs mass to be more than fteen orders of magnitude larger than its observed value this is the so

physics research proposal sample free essay example - Apr 23 2022

web nov 27 2019 essay example on research proposal physics for example in mechanics experts research the motion of the objects which can interact with one another but this branch of physics does not study the reasons and

explorations in physics project proposal guidelines dickinson - Mar 03 2023

web jul 10 2002 proposals are mostly for your benefit you should adhere to the following guidelines format your proposal should be typed on standard 8 x 11 inch paper in addition you should avoid the use of tpestyles that make it difficult to read typically a proposal should be one page in length with an equipment list on a separate page

thesis information mit physics - Jul 27 2022

web thesis committee formation student should consult with their research supervisor to discuss the doctoral thesis committee proposal form which will name the 3 required members of the physics doctoral committee and a descriptive preliminary thesis title doctoral committee must include 3 members with mit physics faculty appointments

research proposal in statement of purpose for integrated phd - Jun 25 2022

web may 4 2021 i wrote this following paragraph in my statement of purpose for my integrated phd physics program in theoretical physics at best research institute in india my research proposal in this field is to quantize general relativity by treating spacetime as a clump of binary grains with few degrees of freedom for field strengths for all fundamental

guidelines for writing a research proposal university of sussex - Aug 08 2023

web the research proposal is central to your application to undertake doctoral study in the department of physics and astronomy you should read the following guidelines to ensure that your proposal includes the information we need to assess your application

research proposal stanford university - Jun 06 2023

web research proposal shravan m hanasoge w w hansen experimental physics laboratory stanford university stanford ca 94305 shravan stanford edu 1 background over the past few years i have worked on simulations of the solar wave field for the purpose of interpreting discovering and testing theories of local and global helioseismology a [2311 04006 towards construction of a novel nm resolution mev](#) - Mar 23 2022

web 2 days ago download pdf abstract driven by life science applications mega electron volt scanning transmission electron microscope mev stem has been proposed to image thick biological samples the high penetration of inelastic scattering signals of mev electrons could make the mev stem an appropriate microscope for biological samples

proposal to the science education initiative abstract - Dec 20 2021

web proposal to the science education initiative abstract the faculty members of the department of physics have a long standing commitment to provide our students with a superb education in the physical sciences we are recognized leaders in the creation and application of innovative education techniques we propose a 4 year program to 1

[phd thesis help department of physics harvard](#) - Nov 30 2022

web phd thesis help guide to preparing and submitting your dissertation top 10 dissertation formatting errors sample dissertation

project proposal for physics 4052 university of minnesota - Aug 28 2022

web j mans project proposal for physics 4052 introduction you must begin thinking about a possible experimental project you want to carry out next semester physics 4052

new york election results 2023 the new york times - May 13 2021

web nov 7 2023 editing by wilson andrews felice belman william p davis dean chang amy hughes ben koski allison mccartney esha ray and dagny salas see full results and maps from the 2023 new york elections

ohio voters approve amendment to establish right to abortion in - Aug 16 2021

web nov 6 2023 the proposal to enshrine abortion access in the ohio constitution was the only one involving reproductive rights directly before voters this election and the first in which voters in a republican

miami dade county mulls the strictest workplace heat rules in the - Jun 13 2021

web nov 6 2023 this county could create the strictest workplace heat rules in the u s martha lopez a farm worker poses for a photo at a farm on november 2 2023 in homestead florida eva marie uzcategui for

research proposal in theoretical physics phys5015 - Jan 01 2023

web outcomes students are able to 1 assess current knowledge in the field of their research project and acquire knowledge of document preparation referencing and conventions appropriate to physics 2 develop written and oral communication skills through preparation of presentation and oral defense of the proposal and 3 work within the

lippincott s illustrated reviews biochemistry international - May 28 2022

web buy lippincott s illustrated reviews biochemistry international student edition lippincott s illustrated reviews series by harvey richard a ferrier denise r 5th fifth revised internat edition 2010 on amazon com free shipping on qualified orders

pdf lippincott s illustrated reviews biochemistry 5th edition - Aug 11 2023

web lippincott s illustrated reviews biochemistry is the long established first and best resource for the essentials of biochemistry students rely on this text to help them quickly review assimilate and integrate large amounts of critical and complex information

biochemistry denise r ferrier google books - Mar 06 2023

web lippincott s illustrated reviews biochemistry is the long established first and best resource for the essentials of biochemistry students rely on this text to help them quickly review assimilate and integrate large amounts of critical and complex information

biochemistry richard a harvey ph d richard a harvey - Jun 09 2023

web thoroughly updated for its fifth edition lippincott s illustrated reviews biochemistry enables students to quickly review and assimilate large amounts of complex information by utilizing

biochemistry lippincott s illustrated review softcover abebooks - Nov 02 2022

web thoroughly updated for its fifth edition lippincott s illustrated reviews biochemistry enables students to quickly review and assimilate large amounts of complex information through powerful visual resources essential to mastery of difficult biochemical concepts

lippincott biochemistry latest edition pdf free download - Jun 28 2022

web download lippincott biochemistry latest edition pdf free now you can download lippincott biochemistry latest edition pdf from medicalstudyzone com below link basic information year 2021 page number 625 pages file type epub file size 110 94 mb authors editors ph d abali emine ercikan download link

lippincott s illustrated reviews biochemistry 5th edition pdf - Dec 03 2022

web lippincott s illustrated reviews biochemistry 5th edition pdf google drive

pdf biochemistry lippincott md hasif sinha academia edu - Apr 26 2022

web biochemistry lippincott biochemistry lippincott md hasif sinha see full pdf download pdf see full pdf download pdf related papers carbohydrate polymers biochemistry and molecular biology 2002 tony stankus download free pdf view pdf obesity surgery miguel angel carbajo md phd 2018

biochemistry 5th edition lippincott s illustrated reviews - Jan 04 2023

web lippincott s illustrated reviews biochemistry is the long established first and best resource for the essentials of

biochemistry students rely on this text to help them quickly review assimilate and integrate large amounts of critical and complex information

[biochemistry lippincott s illustrated review 5th edition](#) - Sep 12 2023

web thoroughly updated for its fifth edition lippincott s illustrated reviews biochemistry enables students to quickly review and assimilate large amounts of complex information through powerful visual resources essential to mastery of difficult biochemical concepts

lippincott s illustrated reviews biochemistry archive org - Jul 30 2022

web lippincott s illustrated reviews biochemistry by harvey richard a ph d publication date 2011 biochemistry pamela c champe richard a harvey denise r ferrier 4th ed c2008 openlibrary edition ol24099132m openlibrary work ol16963316w page number confidence 97 37 pages 534 pdf module

lippincott s illustrated reviews biochemistry 5e medical - May 08 2023

web unit ii intermediary metabolism chapter 6 bioenergetics and oxidative phosphorylation chapter 7 introduction to carbohydrates chapter 8 glycolysis chapter 9 tricarboxylic acid cycle chapter 10 gluconeogenesis chapter 11 glycogen metabolism

[lippincotts illustrated reviews biochemistry 5th edition](#) - Jul 10 2023

web jan 1 2010 good news since this new 5th edition is exactly the same as the eight month older last edition the 4th edition is now an incredible bargain get a copy before they are sold out the 4th edition may be the best

pdf lippincott illustrated reviews biochemistry researchgate - Feb 22 2022

web oct 1 2020 pdf the south asian edition addresses the very real needs of an undergraduate medical student to be able to understand the concepts of biochemistry in find read and cite all the research

[lippincott biochemistry 5th edition pdf](#) - Oct 01 2022

web biochemistry 5th edition updated and revised edition e book jun 21 2023 is an amalgamation of medical and basic sciences and is comprehensively written and later revised and updated to meet the curriculum requirements of medical pharmacy dental veterinary biotechnology

[biochemistry the logic of life medical biochemistry](#) - Aug 31 2022

web feb 21 2014 we would like to show you a description here but the site won t allow us

biochemistry richard a harvey denise r ferrier google books - Feb 05 2023

web thoroughly updated for its fifth edition lippincott s illustrated reviews biochemistry enables students to quickly review and assimilate large amounts of complex information through powerful visual resources essential to mastery of difficult biochemical concepts

lippincott illustrated reviews biochemistry lww - Oct 13 2023

web selected as a doody s core title for 2021 2022 and 2023 praised by faculty and students for more than two decades

lippincott illustrated reviews biochemistry is the long established go to resource for mastering the essentials of biochemistry

[biochemistry lippincott s illustrated reviews series by harvey](#) - Apr 07 2023

web jan 1 2010 publisher lippincott williams wilkins publication date january 1 2010 see all details the amazon book review

book recommendations author interviews editors picks and more

lippincott s illustrated reviews biochemistry fifth ed and - Mar 26 2022

web bibliographic information title lippincott s illustrated reviews biochemistry fifth ed and biochemistry map medmaps

bundle publisher lippincott williams wilkins 2010 isbn 1451116314 9781451116311