

2. DIMENSIONAL DRAWINGS

[] : Extra-long shaft type

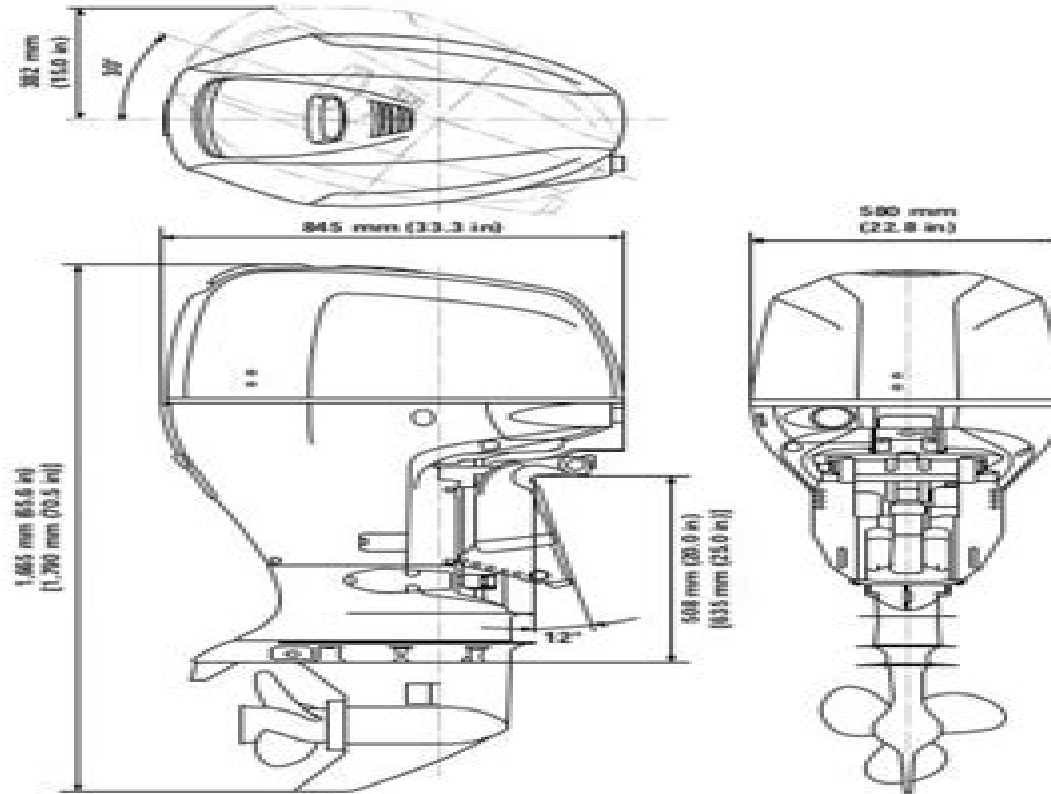

Honda Outboard Instruction Manual

Michal Rosen-Zvi



Honda Outboard Instruction Manual:

Boating Life ,2003-05 **Field & Stream** ,1978-04 FIELD STREAM America s largest outdoor sports magazine celebrates the outdoor experience with great stories compelling photography and sound advice while honoring the traditions hunters and fishermen have passed down for generations **Motorboating - ND** ,1987-01 Popular Mechanics ,1989-06 Popular Mechanics inspires instructs and influences readers to help them master the modern world Whether it s practical DIY home improvement tips gadgets and digital technology information on the newest cars or the latest breakthroughs in science PM is the ultimate guide to our high tech lifestyle Yachting ,1987-03 **Catalogue ...** Montgomery Ward,1970

Popular Mechanics ,1974-03 Popular Mechanics inspires instructs and influences readers to help them master the modern world Whether it s practical DIY home improvement tips gadgets and digital technology information on the newest cars or the latest breakthroughs in science PM is the ultimate guide to our high tech lifestyle **Sailing Made Easy** American Sailing,2010-01-01 Sailing Made Easy is the first step in a voyage that will last you the rest of your life It is a gift from a group of dedicated sailing professionals who have committed their lives to sharing their art their skill and their passion for this wonderful activity This book which Sailing Magazine called best in class upon its release in 2010 is the most comprehensive education and boating safety learn to sail guide to date It is also the official textbook for the ASA Basic Keelboat Standard ASA 101 Incorporated in the textbook are useful illustrations and exceptional photographs of complex sailing concepts The text s most distinguishing feature is its user friendly spreads in which instructional topics are self contained on opposing pages throughout the book There are also chapter end quizzes and a glossary to help those new to sailing to navigate their way through the extensive nautical terminology **Honda Outboard Shop Manual 2-130 HP Four-Stroke 76-05** Penton Staff,2000-05-24 BF20 BF2A BF50 BF5A BF75 BF8A BF100 BF9 9A BF15A BF20A BF25A BF30A BF35A BF40A BF45A BF50A BF75A BF90A BF115A BF130A *Popular Mechanics* ,1982-05 Popular Mechanics inspires instructs and influences readers to help them master the modern world Whether it s practical DIY home improvement tips gadgets and digital technology information on the newest cars or the latest breakthroughs in science PM is the ultimate guide to our high tech lifestyle Field & Stream ,1979-03 FIELD STREAM America s largest outdoor sports magazine celebrates the outdoor experience with great stories compelling photography and sound advice while honoring the traditions hunters and fishermen have passed down for generations Field & Stream ,1978-05 FIELD STREAM America s largest outdoor sports magazine celebrates the outdoor experience with great stories compelling photography and sound advice while honoring the traditions hunters and fishermen have passed down for generations **Field & Stream** ,1978-07 FIELD STREAM America s largest outdoor sports magazine celebrates the outdoor experience with great stories compelling photography and sound advice while honoring the traditions hunters and fishermen have passed down for generations

Field & Stream ,1979-04 FIELD STREAM America s largest outdoor sports magazine celebrates the outdoor experience

with great stories compelling photography and sound advice while honoring the traditions hunters and fishermen have passed down for generations **The Fisherman's Electrical Manual** John C. Payne,2003 This handbook presents the bewildering array of electrical and electronic devices found aboard modern trailerable fishing boats With Payne s help every bass and sports fisherman should be able to make the right choices for his boat s equipment *Field & Stream* ,1985-05 FIELD STREAM America s largest outdoor sports magazine celebrates the outdoor experience with great stories compelling photography and sound advice while honoring the traditions hunters and fishermen have passed down for generations

Boating ,1978-01 *Field & Stream* ,1985-05 FIELD STREAM America s largest outdoor sports magazine celebrates the outdoor experience with great stories compelling photography and sound advice while honoring the traditions hunters and fishermen have passed down for generations *Popular Mechanics* ,1979-03 Popular Mechanics inspires instructs and influences readers to help them master the modern world Whether it s practical DIY home improvement tips gadgets and digital technology information on the newest cars or the latest breakthroughs in science PM is the ultimate guide to our high tech lifestyle **Field & Stream** ,1977-03 FIELD STREAM America s largest outdoor sports magazine celebrates the outdoor experience with great stories compelling photography and sound advice while honoring the traditions hunters and fishermen have passed down for generations

Fuel your quest for knowledge with is thought-provoking masterpiece, Dive into the World of **Honda Outboard Instruction Manual** . This educational ebook, conveniently sized in PDF (*), is a gateway to personal growth and intellectual stimulation. Immerse yourself in the enriching content curated to cater to every eager mind. Download now and embark on a learning journey that promises to expand your horizons. .

https://staging.conocer.cide.edu/files/browse/fetch.php/Marketing_By_Grewal_And_Levy_2nd_Edition.pdf

Table of Contents Honda Outboard Instruction Manual

1. Understanding the eBook Honda Outboard Instruction Manual
 - The Rise of Digital Reading Honda Outboard Instruction Manual
 - Advantages of eBooks Over Traditional Books
2. Identifying Honda Outboard Instruction Manual
 - Exploring Different Genres
 - Considering Fiction vs. Non-Fiction
 - Determining Your Reading Goals
3. Choosing the Right eBook Platform
 - Popular eBook Platforms
 - Features to Look for in an Honda Outboard Instruction Manual
 - User-Friendly Interface
4. Exploring eBook Recommendations from Honda Outboard Instruction Manual
 - Personalized Recommendations
 - Honda Outboard Instruction Manual User Reviews and Ratings
 - Honda Outboard Instruction Manual and Bestseller Lists
5. Accessing Honda Outboard Instruction Manual Free and Paid eBooks
 - Honda Outboard Instruction Manual Public Domain eBooks
 - Honda Outboard Instruction Manual eBook Subscription Services
 - Honda Outboard Instruction Manual Budget-Friendly Options

6. Navigating Honda Outboard Instruction Manual eBook Formats
 - ePub, PDF, MOBI, and More
 - Honda Outboard Instruction Manual Compatibility with Devices
 - Honda Outboard Instruction Manual Enhanced eBook Features
7. Enhancing Your Reading Experience
 - Adjustable Fonts and Text Sizes of Honda Outboard Instruction Manual
 - Highlighting and Note-Taking Honda Outboard Instruction Manual
 - Interactive Elements Honda Outboard Instruction Manual
8. Staying Engaged with Honda Outboard Instruction Manual
 - Joining Online Reading Communities
 - Participating in Virtual Book Clubs
 - Following Authors and Publishers Honda Outboard Instruction Manual
9. Balancing eBooks and Physical Books Honda Outboard Instruction Manual
 - Benefits of a Digital Library
 - Creating a Diverse Reading Collection Honda Outboard Instruction Manual
10. Overcoming Reading Challenges
 - Dealing with Digital Eye Strain
 - Minimizing Distractions
 - Managing Screen Time
11. Cultivating a Reading Routine Honda Outboard Instruction Manual
 - Setting Reading Goals Honda Outboard Instruction Manual
 - Carving Out Dedicated Reading Time
12. Sourcing Reliable Information of Honda Outboard Instruction Manual
 - Fact-Checking eBook Content of Honda Outboard Instruction Manual
 - Distinguishing Credible Sources
13. Promoting Lifelong Learning
 - Utilizing eBooks for Skill Development
 - Exploring Educational eBooks
14. Embracing eBook Trends
 - Integration of Multimedia Elements

- Interactive and Gamified eBooks

Honda Outboard Instruction Manual Introduction

In today's digital age, the availability of Honda Outboard Instruction Manual books and manuals for download has revolutionized the way we access information. Gone are the days of physically flipping through pages and carrying heavy textbooks or manuals. With just a few clicks, we can now access a wealth of knowledge from the comfort of our own homes or on the go. This article will explore the advantages of Honda Outboard Instruction Manual books and manuals for download, along with some popular platforms that offer these resources. One of the significant advantages of Honda Outboard Instruction Manual books and manuals for download is the cost-saving aspect. Traditional books and manuals can be costly, especially if you need to purchase several of them for educational or professional purposes. By accessing Honda Outboard Instruction Manual versions, you eliminate the need to spend money on physical copies. This not only saves you money but also reduces the environmental impact associated with book production and transportation. Furthermore, Honda Outboard Instruction Manual books and manuals for download are incredibly convenient. With just a computer or smartphone and an internet connection, you can access a vast library of resources on any subject imaginable. Whether you're a student looking for textbooks, a professional seeking industry-specific manuals, or someone interested in self-improvement, these digital resources provide an efficient and accessible means of acquiring knowledge. Moreover, PDF books and manuals offer a range of benefits compared to other digital formats. PDF files are designed to retain their formatting regardless of the device used to open them. This ensures that the content appears exactly as intended by the author, with no loss of formatting or missing graphics. Additionally, PDF files can be easily annotated, bookmarked, and searched for specific terms, making them highly practical for studying or referencing. When it comes to accessing Honda Outboard Instruction Manual books and manuals, several platforms offer an extensive collection of resources. One such platform is Project Gutenberg, a nonprofit organization that provides over 60,000 free eBooks. These books are primarily in the public domain, meaning they can be freely distributed and downloaded. Project Gutenberg offers a wide range of classic literature, making it an excellent resource for literature enthusiasts. Another popular platform for Honda Outboard Instruction Manual books and manuals is Open Library. Open Library is an initiative of the Internet Archive, a non-profit organization dedicated to digitizing cultural artifacts and making them accessible to the public. Open Library hosts millions of books, including both public domain works and contemporary titles. It also allows users to borrow digital copies of certain books for a limited period, similar to a library lending system. Additionally, many universities and educational institutions have their own digital libraries that provide free access to PDF books and manuals. These libraries often offer academic texts, research papers, and technical manuals, making them invaluable resources for students and researchers. Some notable examples include MIT OpenCourseWare,

which offers free access to course materials from the Massachusetts Institute of Technology, and the Digital Public Library of America, which provides a vast collection of digitized books and historical documents. In conclusion, Honda Outboard Instruction Manual books and manuals for download have transformed the way we access information. They provide a cost-effective and convenient means of acquiring knowledge, offering the ability to access a vast library of resources at our fingertips. With platforms like Project Gutenberg, Open Library, and various digital libraries offered by educational institutions, we have access to an ever-expanding collection of books and manuals. Whether for educational, professional, or personal purposes, these digital resources serve as valuable tools for continuous learning and self-improvement. So why not take advantage of the vast world of Honda Outboard Instruction Manual books and manuals for download and embark on your journey of knowledge?

FAQs About Honda Outboard Instruction Manual Books

How do I know which eBook platform is the best for me? Finding the best eBook platform depends on your reading preferences and device compatibility. Research different platforms, read user reviews, and explore their features before making a choice. Are free eBooks of good quality? Yes, many reputable platforms offer high-quality free eBooks, including classics and public domain works. However, make sure to verify the source to ensure the eBook credibility. Can I read eBooks without an eReader? Absolutely! Most eBook platforms offer web-based readers or mobile apps that allow you to read eBooks on your computer, tablet, or smartphone. How do I avoid digital eye strain while reading eBooks? To prevent digital eye strain, take regular breaks, adjust the font size and background color, and ensure proper lighting while reading eBooks. What the advantage of interactive eBooks? Interactive eBooks incorporate multimedia elements, quizzes, and activities, enhancing the reader engagement and providing a more immersive learning experience. Honda Outboard Instruction Manual is one of the best book in our library for free trial. We provide copy of Honda Outboard Instruction Manual in digital format, so the resources that you find are reliable. There are also many Ebooks of related with Honda Outboard Instruction Manual. Where to download Honda Outboard Instruction Manual online for free? Are you looking for Honda Outboard Instruction Manual PDF? This is definitely going to save you time and cash in something you should think about.

Find Honda Outboard Instruction Manual :

[marketing by grewal and levy 2nd edition](#)

[mark scheme for 1m j 14](#)

marine manual johnson

mark scheme edexcel maths march 2013 1ma0

market arbiter returns of over 150 in under two years

marine voltage regulator wiring schematic

marine corps planning process

marking scheme 4024 02 o n 03

mariner 60 service manual

marine volvo penta starter wiring diagram

marjing scheme 2m j 13

marketing to the affluent

marketing and unity affiliate program and more money making methods

mariner m90 outboard repair manual

mariner 100 hp workshop manual

Honda Outboard Instruction Manual :

mcgraw hill reading grammar grade 1 practice book - Oct 09 2023

web mcgraw hill reading grammar grade 1 practice book by mcgraw hill publication date 2001 topics reading elementary language arts elementary publisher new york n y mcgraw hill

language arts curriculum programs prek 12 mcgraw hill - Sep 27 2022

web prek 12 language arts programs our comprehensive english language arts and writing products are supported by the science of reading together we can change the approach to literacy instruction and transform all students into skilled readers writers and thinkers the research behind the science of reading

macmillan mcgraw hill language arts free download borrow - Oct 29 2022

web english 7 volumes 29 30 cm dedicated to creating effective communicators through a careful balance of grammar and writing this series helps students obtain the skills instrumental to personal expression grades k 6 includes indexes grade k grade 1 grade 2 grade 3 grade 4 grade 5 grade 6 access restricted item true

macmillan mcgraw hill treasures a reading language arts program grade 1 - Dec 31 2022

web macmillan mcgraw hill treasures a reading language arts program grade 1 english title alternate script none author alternate script none volumes 31 cm grade level 1 unit 1 all about us unit 2 outside my door unit 3 let s connect unit 4 nature watch unit 5 adventures all around unit 6 let s discover

macmillan mcgraw hill reading grades k 6 archive org - Nov 29 2022

web sep 24 2021 volumes 31 cm grades k 6 grade k blue units 1 6 grade 1 yellow books 1 5 unit 1 book 6 unit 2 grade 2 red book 1 units 1 3 book 2 units 1 3 grade 3 green book 1 grade 4 purple pupil s edition units 1 6 grade 5 orange pupil s edition units 1 6 grade 6 teal units 1 6 includes

download mcgraw hill books pdf free complete series - Mar 22 2022

web jun 7 2020 table of mcgraw hill books pdf below is the complete table of contents offered inside mcgraw hill books pdf lange q a usmle step 1 lange clinical neurology 10th edition lange q a psychiatry 11th edition clinical dermatology lange clinical emergency medicine lange pathology flash cards 3rd edition family medicine

mcgraw hill reading grade 1 archive org - Mar 02 2023

web 5 volumes 29 cm grade 1 accompanied by response to proclamation 1997 of the texas state board of education the skills covered in mcgraw hill readiness are the same phonics skills and high frequency words taught in mcgraw hill kindergarten

literature mcgraw hill prek 12 - May 24 2022

web there are currently no items in your shopping cart view cart cart

high school english curriculum studysync mcgraw hill - Feb 18 2022

web studysync 9 12 a comprehensive high school english curriculum bring literature to life for every learner at grades 9 12 studysync provides unprecedented instructional choice presenting teachers with thematic units novel study units teacher created units and chronological options at grades 11 and 12 all while ensuring 100 percent of

mcgraw hill - May 04 2023

web mcgraw hill 2021 school catalog for english language arts ela is a comprehensive guide to the latest curriculum and programs for prek 12 students learn how to enhance your students literacy skills critical thinking and creativity with mcgraw hill s innovative and engaging solutions

mcgraw hill education - Jul 26 2022

web the content is loading

mcgraw hill - Aug 27 2022

web latest news mcgraw hill was named a 2023 best workplace for innovators in education by fast company read more find the path to what s possible every teaching and learning journey is unique and we ll help guide your way find out more

mcgraw hill reading wonders grade 1 on level language - Apr 03 2023

web reading wonders curriculum grade 1 on level you want all your students to build knowledge while exploring our world through literacy literacy is the key to understanding across time borders and cultures and will help students recognize and embrace the role they play in the world they are creating wonders is an evidence based

mcgraw hill language arts grade 1 language advisor - Sep 08 2023

web mcgraw hill language arts grade 1 language arts provides a balanced approach to grammar and writing combining language skills with immediate application to writing students learn through an integrated process using a variety of modes and formats browse the ebook

wonders 2023 mcgraw hill - Feb 01 2023

web wonders wonders expand their world through literacy wonders 2023 is an evidence based k 5 ela program that empowers students to take an active role in learning and exploration

wonders grade 1 free download borrow and streaming - Aug 07 2023

web volumes 20 49 cm wonders a comprehensive k 6 ela eld program is designed to meet the challenges of today s classroom and reach all learners a wealth of research based print and digital resources provide unmatched support for building strong literacy foundations accessing complex texts engaging in collaborative conversations and

literacy curriculum for elementary wonders mcgraw hill - Jul 06 2023

web access support and success for english language learners wonders ell components provide unparalleled support for english language acquisition in all four domains listening speaking reading and writing

free complete textbooks pdfs loads of learning - Apr 22 2022

web english grammar practice grammar reteach spelling workbook vocabulary workbook twelfth grade english grammar practice grammar reteach spelling workbook vocabulary workbook free mcgraw hill and collins collection books prek 12th grade for teachers and homeschooling parents

mcgraw hill language arts grade 1 amazon com - Jun 05 2023

web jan 1 2001 4 4 16 ratings see all formats and editions paperback 31 36 6 used from 29 99 1 new from 138 73 soft cover mcgraw hill grade 1 language arts student book print length 0 pages language english publisher macmillan mcgraw hill school publication date january 1 2001 dimensions 9 5 x 0 75 x 12 inches isbn 10

download top 1200 mcgraw hill books pdf pdfdrive - Jun 24 2022

web 50 most books are stored in the elastic cloud where traffic is expensive for this reason we have a limit on daily download pdfdrive hope give books away get books you want top 1200 mcgraw hill books pdf download free on pdfdrive

best rock songs 43 tunes from classic and modern rock eras - Jul 13 2023

web alfred s best series centers around impeccable piano vocal guitar arrangements of the most loved and recognizable songs in modern music best rock songs highlights tunes

best rock songs 43 tunes from classic and modern rock eras - Apr 10 2023

web buy best rock songs 43 tunes from classic and modern rock eras piano vocal guitar by alfred music online on amazon ae

at best prices fast and free

best rock songs 43 tunes from classic and modern rock eras - Oct 04 2022

web best rock songs 43 tunes from classic and modern rock eras alfred s best series centers around impeccable piano vocal guitar arrangements of the most loved and

100 greatest classic rock songs allmusic - Nov 24 2021

web dec 17 2021 6 joan jett the blackhearts i love rock and roll when you want classic rock songs to play loud put this one on your playlist although this is a cover

best rock songs 43 tunes from classic and modern rock eras - Jan 07 2023

web abebooks com best rock songs 43 tunes from classic and modern rock eras piano vocal guitar best songs 9781470632397 and a great selection of similar

best rock songs 43 tunes from classic and modern rock eras - Feb 08 2023

web best rock songs 43 tunes from classic and modern rock eras 43 tunes from classic and modern rock eras piano vocal guitar alfred music on

the 28 greatest classic rock songs of all time - May 31 2022

web nov 4 2022 the 28 best classic rock songs of all time lighters up these are the classic rock songs that defined an era and changed the face of music written by andy kryza

best rock songs sheet music plus - Mar 09 2023

web best rock songs 43 tunes from classic and modern rock eras piano vocal guitar sheet music book by arrangers

best rock songs 43 tunes from classic and modern copy - Aug 02 2022

web best rock songs 43 tunes from classic and modern is available in our book collection an online access to it is set as public so you can download it instantly our digital library

best rock songs 43 tunes from classic and modern rock eras - May 11 2023

web feb 1 2016 best rock songs 43 tunes from classic and modern rock eras piano vocal guitar best songs alfred music on amazon com free shipping on

the 100 greatest rock songs of the century so far louder - Sep 03 2022

web dec 17 2020 the 100 greatest rock songs of the century so far by paul rees david stubbs paul elliott dom lawson luke morton fraser lewry polly glass philip

best rock songs 43 tunes from classic and modern copy - Sep 22 2021

the 25 best rock songs of all time ew com entertainment weekly - Apr 29 2022

web jul 18 2023 from bruce springsteen s born to run to nirvana s smells like teen spirit here s ew s list of the best rock songs everyone should listen to

best rock songs piano vocal guitar book alfred music - Aug 14 2023

web 43 tunes from classic and modern rock eras by various composers and arrangers piano vocal guitar book alfred s best series centers around impeccable piano vocal guitar arrangements of the most loved and recognizable songs in modern music best rock

best rock songs 20 classic anthems that transcend time - Jan 27 2022

web mar 17 2023 best rock songs 43 tunes from classic and modern thank you for downloading best rock songs 43 tunes from classic and modern as you may know

best rock songs 43 tunes from classic and modern rock eras - Jun 12 2023

web best rock songs book read reviews from world s largest community for readers alfred s best series centers around impeccable piano vocal guitar arrangem

best rock songs 43 tunes from classic and modern rock - Dec 06 2022

web feb 1 2016 buy the book best rock songs 43 tunes from classic and modern rock eras piano vocal guitar by alfred alfred music at indigo

the 10 best new wave of classic rock songs louder - Mar 29 2022

web feb 8 2022 read on for ten great songs that reintroduce a classic sound to modern rock fans greta van fleet heat above in heat above from the 2021 album battle at

best rock songs 43 tunes from classic and modern pdf - Dec 26 2021

web discover 100 greatest classic rock songs by various artists find album reviews track lists credits awards and more at allmusic

top 100 classic rock songs - Feb 25 2022

web aug 12 2021 20 zz top la grange from tres hombres 1973 la grange arguably dukes it out with gimme all your lovin as zz top s signature song but as it remains

best rock songs 43 tunes from classic and modern rock eras - Nov 05 2022

web menu home shop piano vocal guitar pvg patriotic pvg popular pvg classical pvg sacred

top 25 best classic rock songs musician authority - Oct 24 2021

web this best rock songs 43 tunes from classic and modern as one of the most involved sellers here will unconditionally be in the course of the best options to review billboard

50 best rock songs to cover that audiences can t resist - Jul 01 2022

web may 22 2023 we ve put together a list of the 100 best rock songs to cover that we have personally performed with cover bands for many years these aren t just suggestions

europa in der frühen neuzeit neue fischer - May 12 2023

web band 5 der hochkarätigen neuen fischer weltgeschichte europa in der frühen neuzeit reformation aufklärung revolution europa an der schwelle der neuzeit der erste

neue fischer weltgeschichte band 05 europa in der frühen - Aug 03 2022

web jetzt online bestellen heimlieferung oder in filiale neue fischer weltgeschichte band 5 europa in der frühen neuzeit von robert friedeburg orell füssli der buchhändler

neue fischer weltgeschichte s fischer verlage - Aug 15 2023

web band 3 der hochkarätigen neuen fischer weltgeschichte ein panorama des frühmittelalterlichen lebens in europa und dem mittelmeerraum vom spätantiken

fischer weltgeschichte wikipedia - Nov 06 2022

web gegenreformation 109 die lutherische konfessionalisierung 124 die reformierte konfessionalisierung 131 resümee um 1600 religiöse massenmobilisierung und die

neue fischer weltgeschichte bücher in der richtigen reihenfolge - Apr 30 2022

web jun 23 2020 neue fischer weltgeschichte band 15 es sind regionen der sehnsüchte es ist ein kontinent der träume australien neuseeland und die inseln ozeaniens der

neue fischer weltgeschichte reiheninformationen und werke - Apr 11 2023

web neue fischer weltgeschichte band 5 europa in der frühen neuzeit robert friedeburg buch gebundene ausgabe 29 99 inkl gesetzl mwst gebundenes buch

neue fischer weltgeschichte band 5 europa in der frühen - Jul 02 2022

web apr 29 2022 reihenname neue fischer weltgeschichte reinhold kaiser 05 01 1943 kreierte vor über zehn jahren die heute stolze 13 teile umfassende neue fischer

neue fischer weltgeschichte band 05 europa in der frühen - Oct 05 2022

web books like neue fischer weltgeschichte band 05 europa in der frühen neuzeit find out more recommended books with our spot on books app

neue fischer weltgeschichte band 5 von robert friedeburg - Feb 09 2023

web sep 26 2012 band 5 europa in der frühen neuzeit german edition kindle edition by friedeburg robert von download it once and read it on your kindle device pc phones

neue fischer weltgeschichte band 05 europa in der frühen - Jan 08 2023

web band 3 reinhold kaiser die mittelmeerwelt und europa in der spätantike und frühmittelalter 2014 isbn 978 3 10 010823 4
band 4 europa in hoch und

neue fischer weltgeschichte band 5 orell füssli - Jun 01 2022

web der südasiens band der neuen reihe fischer weltgeschichte ließt sich schön und wirft viele interessante fakten und gedankengänge auf und geht dabei von der frühen

neue fischer weltgeschichte band 5 robert von - Jul 14 2023

web band 5 der hochkarätigen neuen fischer weltgeschichte europa in der frühen neuzeit reformation aufklärung revolution europa an der schwelle neue fischer

neue fischer weltgeschichte band 15 s fischer verlage - Feb 26 2022

neue fischer weltgeschichte band 15 australien ozeanien - Jan 28 2022

neue fischer weltgeschichte band 5 robert von friedeburg - Sep 04 2022

web neue fischer weltgeschichte band 5 europa in der frühen neuzeit german edition ebook friedeburg robert von amazon com au kindle store

neue fischer weltgeschichte band 11 südasiens kindle - Mar 30 2022

web neue fischer weltgeschichte band 15 australien ozeanien neuseeland mückler hermann isbn 9783100108456 kostenloser versand für alle bücher mit versand und

die neue fischer weltgeschichte nfwg wissen verbindet - Mar 10 2023

web neue fischer weltgeschichte band 05 europa in der frühen neuzeit friedeburg robert amazon com tr kitap

neue fischer weltgeschichte band 5 europa in der frühen neuzeit - Jun 13 2023

web friedeburg neue fischer weltgeschichte band 5 europa in der frühen neuzeit sachbuch2012buchs fischerisbn 978 3 10 010623 0 29 99 in den warenkorb

neue fischer weltgeschichte band 5 europa in der frühen - Dec 07 2022

web neuware reformation aufklärung revolution europa an der schwelle der neuzeitder erste europa band der neuen fischer weltgeschichte widmet sich der frühen