

Main breaker panel

Connect water heater to generator

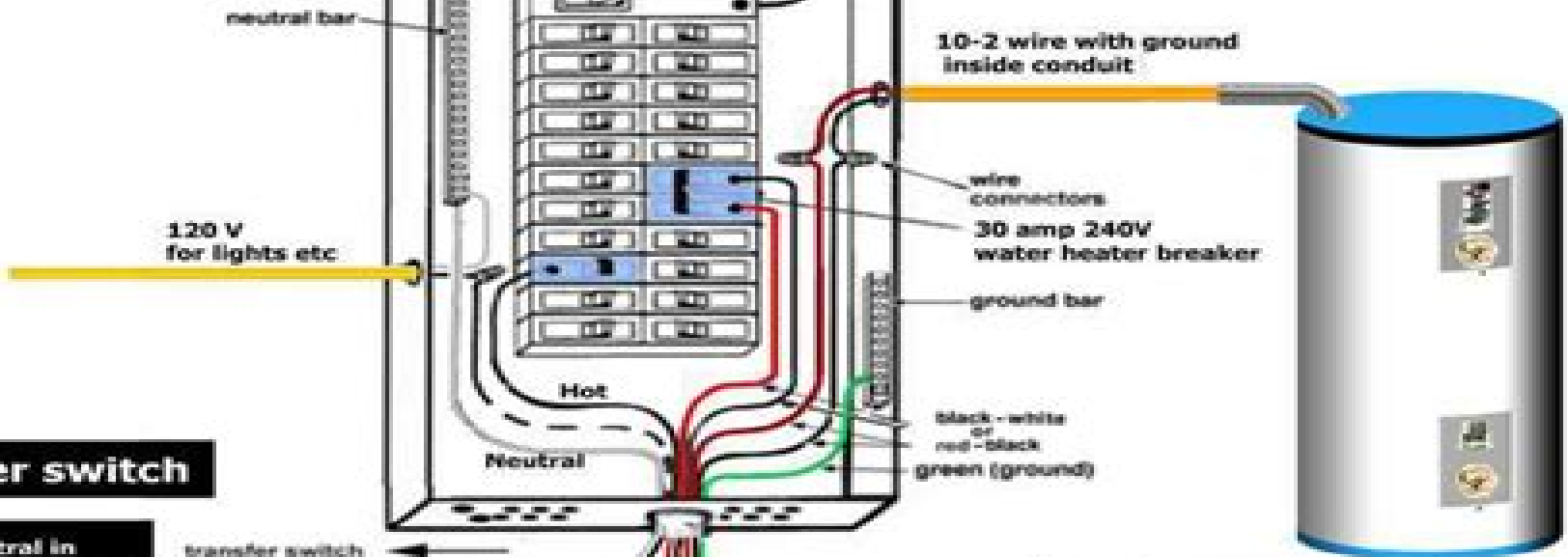

Transfer switch

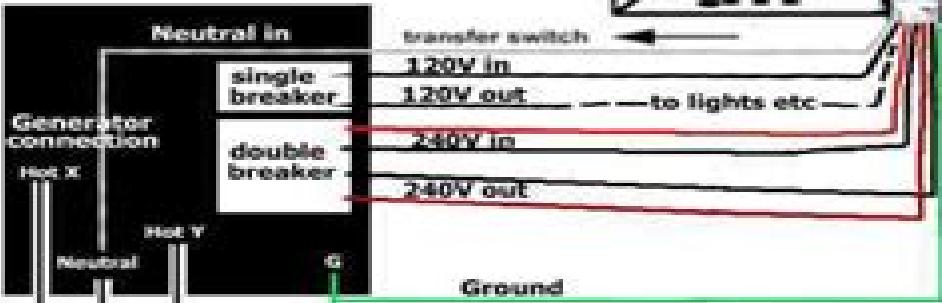

208-240V water heater

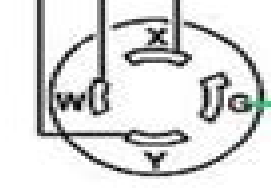

Twist-lock Plug into Generator

125-250V
L14-20P L14-30

How To Wire A Manual Transfer Switch

S Ben Porath



How To Wire A Manual Transfer Switch:

Reviewing **How To Wire A Manual Transfer Switch**: Unlocking the Spellbinding Force of Linguistics

In a fast-paced world fueled by information and interconnectivity, the spellbinding force of linguistics has acquired newfound prominence. Its capacity to evoke emotions, stimulate contemplation, and stimulate metamorphosis is truly astonishing. Within the pages of "**How To Wire A Manual Transfer Switch**," an enthralling opus penned by a very acclaimed wordsmith, readers attempt an immersive expedition to unravel the intricate significance of language and its indelible imprint on our lives. Throughout this assessment, we shall delve in to the book is central motifs, appraise its distinctive narrative style, and gauge its overarching influence on the minds of its readers.

<https://staging.conocer.cide.edu/About/virtual-library/Documents/Gate%20Exam%20Questions%20With%20Answers%20For%20Computer%20Science.pdf>

Table of Contents How To Wire A Manual Transfer Switch

1. Understanding the eBook How To Wire A Manual Transfer Switch
 - The Rise of Digital Reading How To Wire A Manual Transfer Switch
 - Advantages of eBooks Over Traditional Books
2. Identifying How To Wire A Manual Transfer Switch
 - Exploring Different Genres
 - Considering Fiction vs. Non-Fiction
 - Determining Your Reading Goals
3. Choosing the Right eBook Platform
 - Popular eBook Platforms
 - Features to Look for in an How To Wire A Manual Transfer Switch
 - User-Friendly Interface
4. Exploring eBook Recommendations from How To Wire A Manual Transfer Switch
 - Personalized Recommendations
 - How To Wire A Manual Transfer Switch User Reviews and Ratings

- How To Wire A Manual Transfer Switch and Bestseller Lists
- 5. Accessing How To Wire A Manual Transfer Switch Free and Paid eBooks
 - How To Wire A Manual Transfer Switch Public Domain eBooks
 - How To Wire A Manual Transfer Switch eBook Subscription Services
 - How To Wire A Manual Transfer Switch Budget-Friendly Options
- 6. Navigating How To Wire A Manual Transfer Switch eBook Formats
 - ePub, PDF, MOBI, and More
 - How To Wire A Manual Transfer Switch Compatibility with Devices
 - How To Wire A Manual Transfer Switch Enhanced eBook Features
- 7. Enhancing Your Reading Experience
 - Adjustable Fonts and Text Sizes of How To Wire A Manual Transfer Switch
 - Highlighting and Note-Taking How To Wire A Manual Transfer Switch
 - Interactive Elements How To Wire A Manual Transfer Switch
- 8. Staying Engaged with How To Wire A Manual Transfer Switch
 - Joining Online Reading Communities
 - Participating in Virtual Book Clubs
 - Following Authors and Publishers How To Wire A Manual Transfer Switch
- 9. Balancing eBooks and Physical Books How To Wire A Manual Transfer Switch
 - Benefits of a Digital Library
 - Creating a Diverse Reading Collection How To Wire A Manual Transfer Switch
- 10. Overcoming Reading Challenges
 - Dealing with Digital Eye Strain
 - Minimizing Distractions
 - Managing Screen Time
- 11. Cultivating a Reading Routine How To Wire A Manual Transfer Switch
 - Setting Reading Goals How To Wire A Manual Transfer Switch
 - Carving Out Dedicated Reading Time
- 12. Sourcing Reliable Information of How To Wire A Manual Transfer Switch
 - Fact-Checking eBook Content of How To Wire A Manual Transfer Switch
 - Distinguishing Credible Sources

13. Promoting Lifelong Learning
 - Utilizing eBooks for Skill Development
 - Exploring Educational eBooks
14. Embracing eBook Trends
 - Integration of Multimedia Elements
 - Interactive and Gamified eBooks

How To Wire A Manual Transfer Switch Introduction

In the digital age, access to information has become easier than ever before. The ability to download How To Wire A Manual Transfer Switch has revolutionized the way we consume written content. Whether you are a student looking for course material, an avid reader searching for your next favorite book, or a professional seeking research papers, the option to download How To Wire A Manual Transfer Switch has opened up a world of possibilities. Downloading How To Wire A Manual Transfer Switch provides numerous advantages over physical copies of books and documents. Firstly, it is incredibly convenient. Gone are the days of carrying around heavy textbooks or bulky folders filled with papers. With the click of a button, you can gain immediate access to valuable resources on any device. This convenience allows for efficient studying, researching, and reading on the go. Moreover, the cost-effective nature of downloading How To Wire A Manual Transfer Switch has democratized knowledge. Traditional books and academic journals can be expensive, making it difficult for individuals with limited financial resources to access information. By offering free PDF downloads, publishers and authors are enabling a wider audience to benefit from their work. This inclusivity promotes equal opportunities for learning and personal growth. There are numerous websites and platforms where individuals can download How To Wire A Manual Transfer Switch. These websites range from academic databases offering research papers and journals to online libraries with an expansive collection of books from various genres. Many authors and publishers also upload their work to specific websites, granting readers access to their content without any charge. These platforms not only provide access to existing literature but also serve as an excellent platform for undiscovered authors to share their work with the world. However, it is essential to be cautious while downloading How To Wire A Manual Transfer Switch. Some websites may offer pirated or illegally obtained copies of copyrighted material. Engaging in such activities not only violates copyright laws but also undermines the efforts of authors, publishers, and researchers. To ensure ethical downloading, it is advisable to utilize reputable websites that prioritize the legal distribution of content. When downloading How To Wire A Manual Transfer Switch, users should also consider the potential security risks associated with online platforms. Malicious actors may exploit vulnerabilities in unprotected websites to distribute malware or steal personal information. To protect themselves,

individuals should ensure their devices have reliable antivirus software installed and validate the legitimacy of the websites they are downloading from. In conclusion, the ability to download How To Wire A Manual Transfer Switch has transformed the way we access information. With the convenience, cost-effectiveness, and accessibility it offers, free PDF downloads have become a popular choice for students, researchers, and book lovers worldwide. However, it is crucial to engage in ethical downloading practices and prioritize personal security when utilizing online platforms. By doing so, individuals can make the most of the vast array of free PDF resources available and embark on a journey of continuous learning and intellectual growth.

FAQs About How To Wire A Manual Transfer Switch Books

How do I know which eBook platform is the best for me? Finding the best eBook platform depends on your reading preferences and device compatibility. Research different platforms, read user reviews, and explore their features before making a choice. Are free eBooks of good quality? Yes, many reputable platforms offer high-quality free eBooks, including classics and public domain works. However, make sure to verify the source to ensure the eBook credibility. Can I read eBooks without an eReader? Absolutely! Most eBook platforms offer web-based readers or mobile apps that allow you to read eBooks on your computer, tablet, or smartphone. How do I avoid digital eye strain while reading eBooks? To prevent digital eye strain, take regular breaks, adjust the font size and background color, and ensure proper lighting while reading eBooks. What the advantage of interactive eBooks? Interactive eBooks incorporate multimedia elements, quizzes, and activities, enhancing the reader engagement and providing a more immersive learning experience. How To Wire A Manual Transfer Switch is one of the best book in our library for free trial. We provide copy of How To Wire A Manual Transfer Switch in digital format, so the resources that you find are reliable. There are also many Ebooks of related with How To Wire A Manual Transfer Switch. Where to download How To Wire A Manual Transfer Switch online for free? Are you looking for How To Wire A Manual Transfer Switch PDF? This is definitely going to save you time and cash in something you should think about.

Find How To Wire A Manual Transfer Switch :

gate exam questions with answers for computer science

garmin 260 manual

gas dynamics zucrow manual solution

gang up a bikerland novel english edition

gas evolution reactions answer sheet

gateway 710xl motherboard manual

gateway murders the detective cole sullivan series book 3

garfield et cie tome un reacutegime au poil

garmin edge 500 manual usuario

gardner denver air compressor maintenance manual

gateman irevo n10 manual

garber solution manual highway engineering

gateway e6300 manual

~~gaston tome lagaffe nous gacirete~~

garmin forerunner 610 instruction manual

How To Wire A Manual Transfer Switch :

Hilton 9E Global Edition Solutions Manual Chapter10 | PDF Hilton 9E Global Edition Solutions Manual Chapter10 - Free download as PDF File ... McGraw-Hill/Irwin Managerial Accounting, 9/e Global Edition. SOLUTIONS TO ... Hilton 9E Global Edition Solutions Manual Chapter03 | PDF CHAPTER 3. Product Costing and Cost Accumulation in a Batch Production Environment ANSWERS TO REVIEW QUESTIONS 3-1. (a) Use in financial accounting: In ... Hilton 9E Global Edition Solutions Manual Chapter01 CHAPTER 1 The Changing Role of Managerial Accounting in a Global Business Environment ANSWERS TO REVIEW QUESTIONS 1-1T... 8.Hilton 9E Global Edition Solutions Manual Chapter07 ... Cost-volume-profit analysis shows the effect on profit of changes in expenses, sales prices, and sales mix. A change in the hotel's room rate (price) will ... Managerial Accounting Solution Manual Author: David Platt, Ronald Hilton. 766 solutions available. Textbook Solutions for Managerial Accounting. by. 9th Edition. Author: Ronald W. Hilton, Ronald ... Solutions Manual for Managerial Accounting: Creating ... Oct 18, 2023 — Solutions Manual for Managerial Accounting: Creating Value in a Dynamic Business Environment, 13th Edition by Hilton | Verified Chapter's 1 - 17 ... Managerial Accounting Creating Value in a Dynamic ... Apr 14, 2019 — Managerial Accounting Creating Value in a Dynamic Business Environment Global 10th Edition Hilton Solutions Manu Full Download: ... 369916022 managerial accounting 10th edition hilton ... 369916022 managerial accounting 10th edition hilton solution manual doc ; Chapter 02 - Basic Cost Management Concepts ; BASIC COST MANAGEMENT CONCEPTS ; Learning O ... 8.Hilton 9E Global Edition Solutions Manual Chapter07 ... 7-18 Cost-volume-profit analysis shows the effect on profit of changes in expenses, sales prices, and sales mix. A change in the hotel's room rate (price) will ... Epub free Managerial accounting hilton 9th edition solutions ... Jul 6, 2023 — International Edition Management Accounting

Ebook: Managerial Accounting - Global Edition Accounting for Decision Making and Control ... Pokemon Collector's Value Guide: Secondary Market Price ... This book helps the collector determine the value of all Pokémon Cards issued from that time period. I wish and hope that another updated version might be ... Collector's Value Guide: Pokemon Second edition This second edition Collector's Value Guide features color photos of the American, Japanese and the new Neo cards. The book provides a historical journey ... Pokemon Collector's Value Guide Premiere Edition Find many great new & used options and get the best deals for Pokemon Collector's Value Guide Premiere Edition at the best online prices at eBay! checkerbee publishing - pokemon collectors value guide Pokemon Collector's Value Guide: Secondary Market Price Guide and Collector Handbook by CheckerBee Publishing and a great selection of related books, ... Pokemon Collectors Value Guide Paperback 256 Pages ... Pokemon Collectors Value Guide Paperback 256 Pages CheckerBee Publishing 1999. Be the first to write a review. ... No returns, but backed by eBay Money back ... Collector's Value Guide: Pokemon Second edition - Softcover This second edition Collector's Value Guide features color photos of the American, Japanese and the new Neo cards. The book provides a historical journey ... Pokemon: Collector Handbook and Price Guide by ... Pokemon: Collector Handbook and Price Guide Paperback - 1999 ; Date October 25, 1999 ; Illustrated Yes ; ISBN 9781888914672 / 188891467X ; Weight 0.78 lbs (0.35 kg) ... How much are your Pokemon cards worth? Pokemon card price guide. Look up the value of your Pokemon cards using this handy tool. Search for free, get real market prices. Pokemon Collector's Value Guide:... book by CheckerBee ... This book is a really good source if you want to know how much your pokemon cards are worth. This book has the values of rares, commons, and uncommons. And it ... Pokemon Collector's Value Guide: Secondary Market Price ... Learn how to transform old, familiar items and forgotten finds into treasures to tickle your fancy. So easy, even kids can help. Owner Operating Manuals Owner's Manuals: Mercedes-Benz Trucks: Discover all the truck models from Mercedes-Benz such as the Actros, the Arocs, the Atego as well as the ... Workshop Manual Service Manual Mercedes Benz Actros ... workshop-manual-service-manual-mercedes-benz-actros-963 - Read online for free. Mercedes Benz Actros Workshop Manual | PDF We presented complete edition of this book in DjVu, doc, PDF, ePub, txt forms. You may read Mercedes benz actros workshop manual online or load. Additionally, on ... Workshop Manual Mercedes Benz Introduction New Lkw ... No design template Workshop Manual: Introductory Manual for Customer Service / System Description Mercedes Benz launch of new Actros truck series Types: ... Mercedes Actros Workshop Repair Manual Download Official Mercedes Benz Actros Workshop Manual is the complete Service Repair Information System containing comprehensive illustrations and wiring diagrams, ... Mercedes-Benz Actros, Antos, Arocs Full Service Manual ... Aug 5, 2022 — Mercedes-Benz Actros, Antos, Arocs Full Service Manual 2014.pdf. by Admin | Aug 5, 2022. Download. Categories: Mercedes-Benz Actros. Mercedes-benz Actros Manuals Manuals and User Guides for Mercedes-Benz Actros. We have 1 Mercedes-Benz Actros manual available for free PDF download: Operating Instructions Manual ... Mercedes benz actros maintenance manual Feb 23, 2016 — Sep 1, 2018 - Mercedes Benz

Actros Maintenance Manual Free download mercedes benz actros maintenance manual PDF PDF Manuals Library
MERCEDES ... Mercedes Benz Actros Forum, Classifieds, Photo gallery, Videos, Manuals, Servicebook, Engines, Advisory.
Truck Guides Truck Guides. Here, you can download operating instructions, supplements and maintenance Booklet in PDF
format. Please make your selection: Family. Document ...