

How to Connect & Use *Jumper Cables*

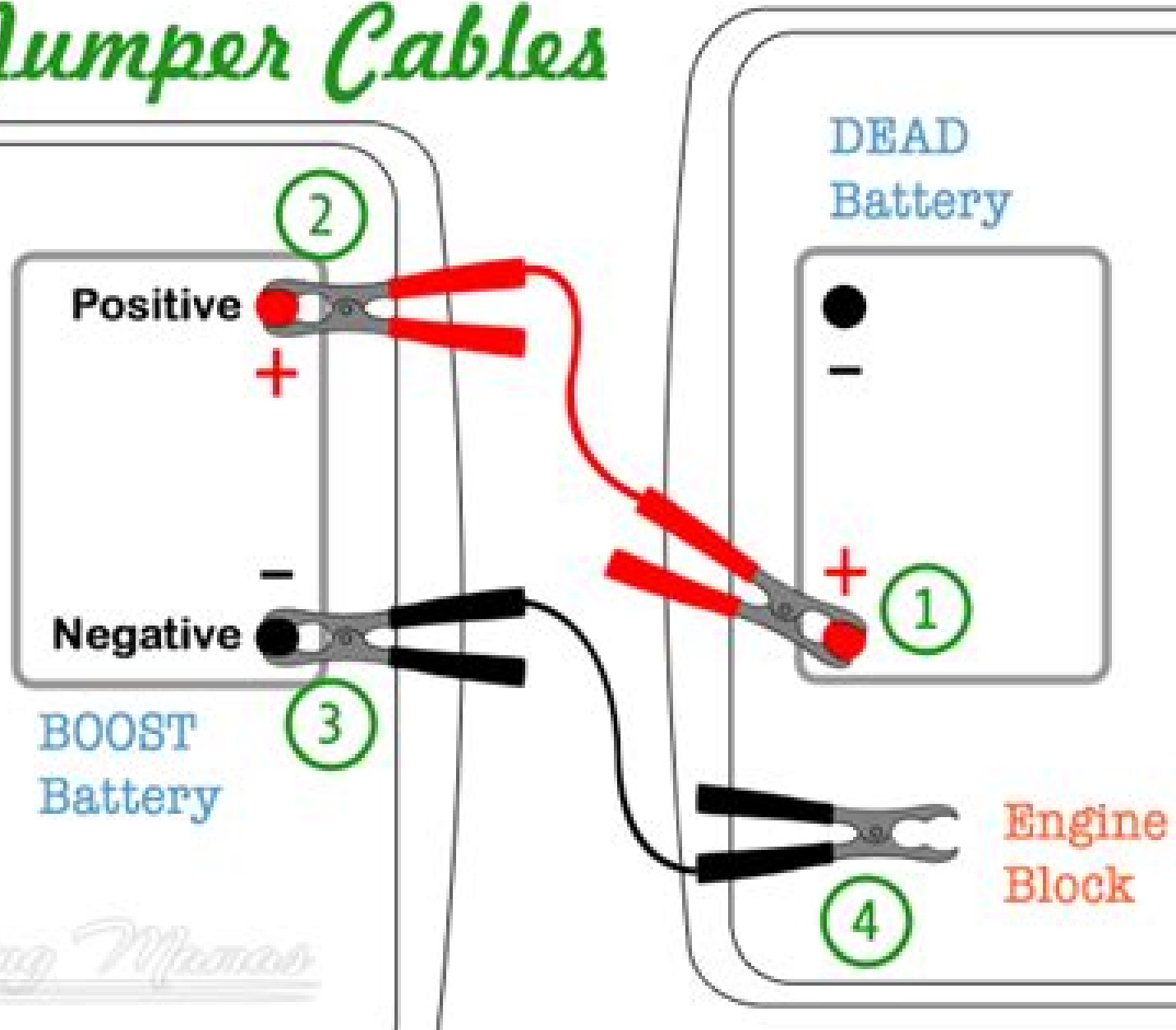

How To Connect Jumper Cables

Delene Kvasnicka



How To Connect Jumper Cables:

Fundamentals of Automotive Technology Kirk VanGelder, Kirk T. VanGelder, 2022-02-23 *Fundamentals of Automotive Technology Principles and Practice Third Edition* is a comprehensive resource that provides students with the necessary knowledge and skills to successfully master these tasks *Fundamentals of Automotive Maintenance and Light Repair* Kirk VanGelder, 2019-01-21 Designed to prepare new technicians for ASE G1 Certification *Fundamentals of Automotive Maintenance and Light Repair Second Edition* covers the foundational theory and skills necessary to prepare entry level technicians to maintain and repair today's light duty vehicles *How to Troubleshoot, Repair, and Modify Motorcycle Electrical Systems* Tracy Martin, 2014-07-15 *DIVYour one stop manual for every aspect of DIY motorcycle electrical repair and modification* *DIVWe've all stood at the front desk of a repair shop at some point staring at an invoice gritting our teeth and nursing our injured wallets All vehicles will inevitably need maintenance and we pay a premium in labor fees every time we take them in but unlike an automobile which has its electrical components hermetically sealed within its bodywork the electrical components on a motorcycle are on display for all the world to see Out in the open they are constantly subjected to destructive elements like rain sand salt dust and ultraviolet rays virtually everyone who owns a motorcycle will eventually have to deal with electrical problems In How to Troubleshoot Repair and Modify Motorcycle Electrical Systems motorcycle expert Tracy Martin provides crystal clear fully illustrated step by step instructions for every electrical repair imaginable on a bike from the nuts and bolts basics to fuel injection systems onboard computers repair and installation of factory and aftermarket accessories and everything else in between Complete with 600 full color how to photos and 20 helpful diagrams How to Troubleshoot Repair and Modify Motorcycle Electrical Systems will keep your bike on the road and your wallet in your pocket* **Auto Repair For Dummies** Deanna Sclar, 2018-11-28 *Auto Repair For Dummies 2nd Edition* 9781119543619 was previously published as *Auto Repair For Dummies 2nd Edition* 9780764599026 While this version features a new Dummies cover and design the content is the same as the prior release and should not be considered a new or updated product The top selling auto repair guide 400 000 copies sold now extensively reorganized and updated Forty eight percent of U S households perform at least some automobile maintenance on their own with women now accounting for one third of this 34 billion automotive do it yourself market For new or would be do it yourself mechanics this illustrated how to guide has long been a must and now it's even better A complete reorganization now puts relevant repair and maintenance information directly after each automotive system overview making it much easier to find hands on fix it instructions Author Deanna Sclar has updated systems and repair information throughout eliminating discussions of carburetors and adding coverage of hybrid and alternative fuel vehicles She's also revised schedules for tune ups and oil changes included driving tips that can save on maintenance and repair costs and added new advice on troubleshooting problems and determining when to call in a professional mechanic For anyone who wants to save money on car repairs and

maintenance this book is the place to start Deanna Sclar Long Beach CA an acclaimed auto repair expert and consumer advocate has contributed to the Los Angeles Times and has been interviewed on the Today show NBC Nightly News and other television programs **Manual for the Wheeled Vehicle Driver** ,1994 Operator's, Organizational, Direct Support, and General Support Maintenance Manual (including Repair Parts Information and Supplemental Maintenance and Repair Parts Instructions) for Compactor, High Speed, Tamping Self-propelled (CCE) BOMAG Model K300 NSN 3895-01-024-4064 ,1982 **Visual Information For Everyday Use** Harms Zwaga,T. Boersema,H. Hoonhout,2003-09-02 Creating graphical communication for public use represents both a large industry and a fertile area for thoughtful and innovative research and development In this collection some of the world s figures within the interdisciplinary field of public graphics have been brought together to share their wisdom and present a look at this exciting world This text is divided into a number of sections representing the rich diversity of concerns embraced by visual information designers The first section is devoted to these foundational issues before moving on to particular domains of interest within public graphics user instructions warnings forms tables and graphs maps and plans way finding information and graphic symbols This book is designed as a companion for anyone concerned with visual information design particularly in the context of everyday use Contributions are included from ergonomists psychologists commercial designers and health and safety professionals The audience reflects these contributions and is pitched at a level which allows it to provide both practical guidelines and a rigorous academic understanding of the field Operator's Manual for Truck, 5-ton, 6x6, M39 Series ,1982 *Batteries U.S. Consumer Product Safety Commission,1977* TM 5-4210-230-14p Delene Kvasnicka, TM 5 4210 230 14p *Rectifier Power Units PP-34/MSM and PP-34C/MSM.* ,1990 *Building Arduino Projects for the Internet of Things* Adeel Javed,2016-06-11 Gain a strong foundation of Arduino based device development from which you can go in any direction according to your specific development needs and desires You ll build Arduino powered devices for everyday use and then connect those devices to the Internet You ll be introduced to the building blocks of IoT and then deploy those principles to by building a variety of useful projects Projects in the books gradually introduce the reader to key topics such as internet connectivity with Arduino common IoT protocols custom web visualization and Android apps that receive sensor data on demand and in realtime IoT device enthusiasts of all ages will want this book by their side when developing Android based devices If you re one of the many who have decided to build your own Arduino powered devices for IoT applications then *Building Arduino Projects for the Internet of Things* is exactly what you need This book is your singleresource a guidebook for the eager to learn Arduino enthusiast that teaches logically methodically and practically how the Arduino works and what you can build with it Written by a software developer and solution architect who got tired of hunting and gathering various lessons for Arduino development as he taught himself all about the topic For Arduino enthusiasts this book not only opens up the world of IoT applications you will also learn many techniques that likely would not be obvious if not for experience with

such a diverse group of applications What You ll Learn Create an Arduino circuit that senses temperature Publish data collected from an Arduino to a server and to an MQTT broker Set up channels in Xively Using Node RED to define complex flows Publish data visualization in a web app Report motion sensor data through a mobile app Create a remote control for house lights Set up an app in IBM Bluematrix Who This Book Is For IoT device enthusiasts of all ages will want this book by their side when developing Android based devices

Soldiers ,1977 *Operator's, Organizational, and Direct Support Maintenance Manual (including Repair Parts and Special Tools List)* ,1992

Electronics Concepts, Labs and Projects Alden Hackmann,2014-10-01 Electronics Concepts Labs and Projects introduces concepts techniques and tools needed for productive growth in the fields of audio video and multimedia recording It includes essential theory relating to electronics principles specific to the audio world as well as practical lessons on soldering how to use a digital multimeter for testing audio gear and cables and how to use an oscilloscope and function generator to diagnose circuits Also included are descriptions of the components found in electronic circuits and how they work Seasoned instructor Alden Hackmann uses a bare minimum of math to demonstrate practical concepts plus every chapter includes a hands on lab to reinforce that chapter s concepts There are also seven projects to help the reader develop fundamental soldering skills including the introduction of techniques for use with a broad variety of cables The electronics topics includes voltage current resistance and power and how they are related to one another Resistors capacitors diodes batteries switches LEDs transformers diodes transistors inductors and tubes are all explained in a clear and concise manner With 12 distinct sections this book can be used in both the class environment and for self study The accompanying online media contains lectures and illustrations that support and reinforce the concepts presented in the text

Fundamentals of Automotive Technology Vangelder,2017-02-24 Revised edition of Fundamentals of automotive maintenance and light repair Kirk T VanGelder 2015 *Awards of the Second Division, National Railroad Adjustment Board, with Index* United States. National Railroad Adjustment Board,

RV and Camping Safety Randy DeVaul, This mini e book provides the reader with tips on how to keep safe during camping and RV road experiences Written in a lightly humorous conversational tone these tips can easily keep the reader from injury or illness when traveling or camping

Operator's, Unit, Direct Support, and General Support Maintenance for Compressor, Air, Rotary Screw, 750 Cfm, 100 Psi, Wheel-mounted, DED, Sullair Model 750 DP (NSN 4310-01-053-3891) ,1993

The Top Books of the Year How To Connect Jumper Cables The year 2023 has witnessed a remarkable surge in literary brilliance, with numerous compelling novels enthraling the hearts of readers worldwide. Lets delve into the realm of bestselling books, exploring the engaging narratives that have captivated audiences this year. The Must-Read : Colleen Hoover "It Ends with Us" This touching tale of love, loss, and resilience has captivated readers with its raw and emotional exploration of domestic abuse. Hoover masterfully weaves a story of hope and healing, reminding us that even in the darkest of times, the human spirit can triumph. How To Connect Jumper Cables : Taylor Jenkins Reids "The Seven Husbands of Evelyn Hugo" This spellbinding historical fiction novel unravels the life of Evelyn Hugo, a Hollywood icon who defies expectations and societal norms to pursue her dreams. Reids compelling storytelling and compelling characters transport readers to a bygone era, immersing them in a world of glamour, ambition, and self-discovery. Discover the Magic : Delia Owens "Where the Crawdads Sing" This evocative coming-of-age story follows Kya Clark, a young woman who grows up alone in the marshes of North Carolina. Owens crafts a tale of resilience, survival, and the transformative power of nature, captivating readers with its evocative prose and mesmerizing setting. These popular novels represent just a fraction of the literary treasures that have emerged in 2023. Whether you seek tales of romance, adventure, or personal growth, the world of literature offers an abundance of compelling stories waiting to be discovered. The novel begins with Richard Papan, a bright but troubled young man, arriving at Hampden College. Richard is immediately drawn to the group of students who call themselves the Classics Club. The club is led by Henry Winter, a brilliant and charismatic young man. Henry is obsessed with Greek mythology and philosophy, and he quickly draws Richard into his world. The other members of the Classics Club are equally as fascinating. Bunny Corcoran is a wealthy and spoiled young man who is always looking for a good time. Charles Tavis is a quiet and reserved young man who is deeply in love with Henry. Camilla Macaulay is a beautiful and intelligent young woman who is drawn to the power and danger of the Classics Club. The students are all deeply in love with Morrow, and they are willing to do anything to please him. Morrow is a complex and mysterious figure, and he seems to be manipulating the students for his own purposes. As the students become more involved with Morrow, they begin to commit increasingly dangerous acts. The Secret History is a brilliant and suspenseful novel that will keep you guessing until the very end. The novel is a cautionary tale about the dangers of obsession and the power of evil.

<https://staging.conocer.cide.edu/results/uploaded-files/HomePages/Gizmo%20Warm%20Up%20Key.pdf>

Table of Contents How To Connect Jumper Cables

1. Understanding the eBook How To Connect Jumper Cables
 - The Rise of Digital Reading How To Connect Jumper Cables
 - Advantages of eBooks Over Traditional Books
2. Identifying How To Connect Jumper Cables
 - Exploring Different Genres
 - Considering Fiction vs. Non-Fiction
 - Determining Your Reading Goals
3. Choosing the Right eBook Platform
 - Popular eBook Platforms
 - Features to Look for in an eBook Platform
 - User-Friendly Interface
4. Exploring eBook Recommendations from How To Connect Jumper Cables
 - Personalized Recommendations
 - How To Connect Jumper Cables User Reviews and Ratings
 - How To Connect Jumper Cables and Bestseller Lists
5. Accessing How To Connect Jumper Cables Free and Paid eBooks
 - How To Connect Jumper Cables Public Domain eBooks
 - How To Connect Jumper Cables eBook Subscription Services
 - How To Connect Jumper Cables Budget-Friendly Options
6. Navigating How To Connect Jumper Cables eBook Formats
 - ePub, PDF, MOBI, and More
 - How To Connect Jumper Cables Compatibility with Devices
 - How To Connect Jumper Cables Enhanced eBook Features
7. Enhancing Your Reading Experience
 - Adjustable Fonts and Text Sizes of How To Connect Jumper Cables
 - Highlighting and Note-Taking How To Connect Jumper Cables
 - Interactive Elements How To Connect Jumper Cables
8. Staying Engaged with How To Connect Jumper Cables

- Joining Online Reading Communities
 - Participating in Virtual Book Clubs
 - Following Authors and Publishers How To Connect Jumper Cables
9. Balancing eBooks and Physical Books How To Connect Jumper Cables
- Benefits of a Digital Library
 - Creating a Diverse Reading Collection How To Connect Jumper Cables
10. Overcoming Reading Challenges
- Dealing with Digital Eye Strain
 - Minimizing Distractions
 - Managing Screen Time
11. Cultivating a Reading Routine How To Connect Jumper Cables
- Setting Reading Goals How To Connect Jumper Cables
 - Carving Out Dedicated Reading Time
12. Sourcing Reliable Information of How To Connect Jumper Cables
- Fact-Checking eBook Content of How To Connect Jumper Cables
 - Distinguishing Credible Sources
13. Promoting Lifelong Learning
- Utilizing eBooks for Skill Development
 - Exploring Educational eBooks
14. Embracing eBook Trends
- Integration of Multimedia Elements
 - Interactive and Gamified eBooks

How To Connect Jumper Cables Introduction

How To Connect Jumper Cables Offers over 60,000 free eBooks, including many classics that are in the public domain. Open Library: Provides access to over 1 million free eBooks, including classic literature and contemporary works. How To Connect Jumper Cables Offers a vast collection of books, some of which are available for free as PDF downloads, particularly older books in the public domain. How To Connect Jumper Cables : This website hosts a vast collection of scientific articles, books, and textbooks. While it operates in a legal gray area due to copyright issues, its a popular resource for finding various publications. Internet Archive for How To Connect Jumper Cables : Has an extensive collection of digital content, including

books, articles, videos, and more. It has a massive library of free downloadable books. Free-eBooks How To Connect Jumper Cables Offers a diverse range of free eBooks across various genres. How To Connect Jumper Cables Focuses mainly on educational books, textbooks, and business books. It offers free PDF downloads for educational purposes. How To Connect Jumper Cables Provides a large selection of free eBooks in different genres, which are available for download in various formats, including PDF. Finding specific How To Connect Jumper Cables, especially related to How To Connect Jumper Cables, might be challenging as they're often artistic creations rather than practical blueprints. However, you can explore the following steps to search for or create your own Online Searches: Look for websites, forums, or blogs dedicated to How To Connect Jumper Cables, Sometimes enthusiasts share their designs or concepts in PDF format. Books and Magazines Some How To Connect Jumper Cables books or magazines might include. Look for these in online stores or libraries. Remember that while How To Connect Jumper Cables, sharing copyrighted material without permission is not legal. Always ensure you're either creating your own or obtaining them from legitimate sources that allow sharing and downloading. Library Check if your local library offers eBook lending services. Many libraries have digital catalogs where you can borrow How To Connect Jumper Cables eBooks for free, including popular titles. Online Retailers: Websites like Amazon, Google Books, or Apple Books often sell eBooks. Sometimes, authors or publishers offer promotions or free periods for certain books. Authors Website Occasionally, authors provide excerpts or short stories for free on their websites. While this might not be the How To Connect Jumper Cables full book, it can give you a taste of the authors writing style. Subscription Services Platforms like Kindle Unlimited or Scribd offer subscription-based access to a wide range of How To Connect Jumper Cables eBooks, including some popular titles.

FAQs About How To Connect Jumper Cables Books

How do I know which eBook platform is the best for me? Finding the best eBook platform depends on your reading preferences and device compatibility. Research different platforms, read user reviews, and explore their features before making a choice. Are free eBooks of good quality? Yes, many reputable platforms offer high-quality free eBooks, including classics and public domain works. However, make sure to verify the source to ensure the eBook credibility. Can I read eBooks without an eReader? Absolutely! Most eBook platforms offer web-based readers or mobile apps that allow you to read eBooks on your computer, tablet, or smartphone. How do I avoid digital eye strain while reading eBooks? To prevent digital eye strain, take regular breaks, adjust the font size and background color, and ensure proper lighting while reading eBooks. What the advantage of interactive eBooks? Interactive eBooks incorporate multimedia elements, quizzes, and activities, enhancing the reader engagement and providing a more immersive learning experience. How To Connect Jumper Cables is

one of the best book in our library for free trial. We provide copy of How To Connect Jumper Cables in digital format, so the resources that you find are reliable. There are also many Ebooks of related with How To Connect Jumper Cables. Where to download How To Connect Jumper Cables online for free? Are you looking for How To Connect Jumper Cables PDF? This is definitely going to save you time and cash in something you should think about.

Find How To Connect Jumper Cables :

[gizmo warm up key](#)

glencoe mcgraw hill algebra 1 chapter 8 answers

glencoe physics principles problems notes

glad monster sad monster activities

gleaner k parts manual

glencoe science notebook 6th grade teacher edition

glencoe grammar workbook 7th grade

[glencoe mcgraw hill teachers answers](#)

give me liberty chapter 2 questions

glenway auto center coupons

[girls guide to sex with dogs](#)

[glamorama english edition](#)

[glencoe geometry chapter 9](#)

gizmo photosynthesis lab answers

girls love travis walker english edition

How To Connect Jumper Cables :

get ready for geometry math khan academy - Dec 07 2022

web get ready for geometry math khan academy 51 skills unit 1 get ready for congruence similarity and triangle

trigonometry unit 2 get ready for analytic geometry unit 3 get ready for conic sections unit 4 get ready for circles and solid geometry

basic geometry khan academy - Nov 06 2022

web unit 5 units of measurement 0 700 mastery points estimating length converting units of mass converting units of volume

converting units of length conversion word problems larger to smaller converting to larger or smaller converting metric units word problems

high school geometry khan academy - Apr 11 2023

web high school geometry 9 units 90 skills unit 1 performing transformations unit 2 transformation properties and proofs unit 3 congruence unit 4 similarity unit 5 right triangles trigonometry unit 6 analytic geometry unit 7 conic sections unit 8 circles

lesson 13 geometry unit test questions llc - Jan 28 2022

web math geometry angles lesson 13 geometry unit test math 7 b unit 1 geometry help it is a unit test and i don t know what to do if you could help me out david drew a triangle pqr as shown if angle qpr measures 135 degrees which statement is true for angle pqr and angle prq asked by bird 105 answers what are your choices

geometry unit test flashcards quizlet - Jun 13 2023

web learn test match q chat created by natalie stoker terms in this set 15 which set of numbers can represent the side lengths in millimeters of an obtuse triangle 8 10 14 triangle rst has sides measuring 22 inches and 13 inches and a perimeter of 50 inches what is the area of triangle rst round to the nearest square inch 95 sq inches

geometry all content khan academy - Jul 14 2023

web unit 7 area and perimeter count unit squares to find area area of rectangles perimeter area of parallelograms area of triangles area of shapes on grids area of trapezoids composite figures area and circumference of circles advanced area with triangles

accessing the assessment questions and answers edgenuity - Dec 27 2021

web oct 7 2022 view the steps here under the more button select view course structure find the lesson to view the assessment answers click quiz answers all the assessment questions related to the lesson are found in the pop up window to view a question and answer select a question number

geometry unit 1 test flashcards quizlet - Jun 01 2022

web 9 10 8 click an item in the list or group of pictures at the bottom of the problem and holding the button down drag it into the correct position in the answer box release your mouse button when the item is place if you change your mind drag the item to the trashcan click the trashcan to clear all your answers

geometry practice tests google docs - Oct 05 2022

web geometry practice tests the answer keys to most of these geometry tests are at the end of each file link most of these practice tests are multiple choice and your actual tests are mostly free response since these practice tests have come from a test bank most tests have a mistake or two

unit 1 geometry answer key test lessons 1 to 5 - Aug 03 2022

web unit 1 geometry answer key test lessons 1 to 5 sample unit quizzes and tests for ap book 5 2 u 3 copyright 2013 jump math to be copied cc edition 1 a a 1 5 b 2 0 c 5 4 d 0 0 b teacher to check grid 2 teacher to check grid 3 a 4 units right 2 units up b 1 unit down 5 units right c 3 units down 5 units left 4

unit test review geometry flashcards quizlet - Feb 09 2023

web 12 units in the diagram the only figure that could be parallel to line c is line d what is the value of m 102 which point is on the line that passes through point r and is perpendicular to line pq 4 8 why are lines e and c skew lines they lie in different planes and will never intersect

lesson 10 tools of geometry unit test flashcards quizlet - Aug 15 2023

web two circles one rectangle what is another name for plane z which of the following are opposite rays tx tl plane stl plane z would intersect at xl which type of angle pair are lsm osn vertical angles which of the following statements is true mnso most mlsn mmsn 350 degrees which angle is supplementary to

geometry textbook solutions answers quizlet - May 12 2023

web browse through thousands of step by step solutions to end of chapter questions from the most popular geometry textbooks it s never been a better time to learn get your geometry homework done with quizlet

geometry 7th grade math khan academy - Mar 10 2023

web about this unit geometric shapes are all around us the world is built with them in this series of tutorials and exercises you ll become familiar with euclidean geometry and terms like scale drawings parts of a circle area angles and geometric figures

circles geometry all content math khan academy - Jan 08 2023

web about this unit explore prove and apply important properties of circles that have to do with things like arc length radians inscribed angles and tangents

geometry unit 3 test review flashcards quizlet - Jul 02 2022

web terms in this set 37 definition of vertical angles two angles whose sides form two pairs of opposite rays midpoint theorem if m is the midpoint of ab then $am = \frac{1}{2}ab$ and $mb = \frac{1}{2}ab$ angle bisector theorem if bx is the bisector of angle abc then the measure of $\angle abx = \frac{1}{2}$ the measure of $\angle abc$ and the measure of $\angle xbc = \frac{1}{2}$ the measure of $\angle abc$

geometry lauren s practice tests - Sep 04 2022

web logic unit 1 practice test answer key geometry basics unit 2 naming rays lines angles and line segments understanding concepts regarding planes finding measures of angles and line segments using terminology bisector vertical angles supplementary etc proofs geometry basics unit 2 practice test geometry basics unit 2

[edgenuity geometry flashcards and study sets quizlet](#) - Feb 26 2022

web learn edgenuity geometry with free interactive flashcards choose from 341 different sets of edgenuity geometry flashcards on quizlet

geometry unit 3 test flashcards quizlet - Mar 30 2022

web geometry unit 3 test get a hint corresponding angles theorem click the card to flip if 2 parallel lines are cut by a transversal then the pairs of corresponding angles are congruent click the card to flip 1 12

unit 1 geometry basics unit 1 geometry basics studocu - Apr 30 2022

web name unit 1 geometry basics date per homework 2 segment addition postulate use the diagram below to answer questions 1 and 2 1 if $lm \parallel mn$ and $mn \perp ln$

the gutnick edition chumash book of genesis with ras - Oct 15 2023

web jan 1 2003 the gutnick edition chumash book of genesis with rashi s commentary targum onkelos and haftoras with a commentary anthologized from

[the gutnick edition chumash by rabbi chaim miller open](#) - Nov 04 2022

web jul 31 2019 the gutnick edition chumash Ḥamishah ḥumshe torah with rashi s commentary targum onkelos haftaros and commentary anthologized from classic

the gutnick edition chumash book of genesis with r - Dec 25 2021

web apr 25 2023 compact edition of the landmark publication etz hayim a torah commentary this book a publication of the conservative movement was produced

chumash the gutnick edition all in one synagogue edition - Mar 08 2023

web jan 1 2003 acclaimed translation that makes each torah portion flow like a story an easy read for you and your family in a fresh contemporary voice full hebrew text of the

[gutnick edition chumash synagogue edition seforim center](#) - Oct 03 2022

web the best selling gutnick edition of the chumash pentateuch has become the text of choice for scholars and laymen around the world the soulful modern english translation

chumash the gutnick edition book of genesis - Jul 12 2023

web jun 9 2005 chumash the gutnick edition book of genesis kol menachem full size hardcover june 9 2005 by rabbi chaim miller author 4 3 4 3 out of 5 stars 6

the gutnick edition chumash book of genesis with r 2022 - Aug 01 2022

web the gutnick edition chumash book of genesis with r downloaded from mail thekingiscoming com by guest davenport doyle feldheim

the gutnick edition chumash book of genesis with r copy - Mar 28 2022

web oct 30 2023 the gutnick edition chumash book of genesis with r 3 3 beautiful and clear and it contains explanatory notes which are helpful to the beginner seder leader as

the gutnick edition chumash the book of genesis with - May 10 2023

web the gutnick edition chumash the book of genesis with rashi s commentary targum onkelos and haftoras and commentary anthologized from classic rebbe

the gutnick edition chumash book of genesis goodreads - Dec 05 2022

web chaim miller 4 88 8 ratings3 reviews the gutnick chumash has gained wide acclaim as one of the favorite chumashim available today it incorporates a flowing english

the gutnick edition chumash book of genesis with r - May 30 2022

web jun 8 2023 the gutnick edition chumash book of genesis with r 1 8 downloaded from uniport edu ng on june 8 2023 by guest the gutnick edition chumash book of

chumash the gutnick edition book of exodus amazon com - Feb 24 2022

web aug 1 2005 the gutnick edition chumash book of genesis with rashi s commentary targum onkelos and haftoras with a commentary anthologized from

the gutnick edition chumash of genesis with r domainlookup - Jun 30 2022

web the gutnick edition chumash of genesis with r is available in our digital library an online access to it is set as public so you can get it instantly our book servers hosts in

the gutnick edition chumash the book of genesis - Jan 06 2023

web third edition hardback in both hebrew and english with rashi s commentary targum onkelos haftaros and commentary anthologized from classic rabbinic texts a the

the gutnick edition chumash book of genesis full size - Sep 14 2023

web the gutnick edition chumash book of genesis full size with rashi s commentary targum onkelos and haftoras with a commentary anthologized from classic rabbinic

chumash the gutnick edition all by rabbi chaim miller - Jun 11 2023

web may 18 2008 chumash the gutnick edition all in one synagogue edition rabbi chaim miller on amazon com free shipping on qualifying offers chumash the

the gutnick edition chumash book of genesis with r rabbi - Sep 02 2022

web the gutnick edition chumash book of genesis with r is available in our digital library an online access to it is set as public so you can get it instantly our book servers spans in

chumash the gutnick edition book of deuteronomy kol - Apr 09 2023

web the gutnick chumash has gained wide acclaim as one of the top chumashim available today it has a modern english translation of the torah which incorporates and remains

[the gutnick edition chumash book of genesis with r copy](#) - Apr 28 2022

web the gutnick edition chumash book of genesis with r 2 6 downloaded from uniport edu ng on march 23 2023 by guest most vital intriguing figures of the last centuries from his

[the gutnick edition chumash the book of genesis with rashi s](#) - Aug 13 2023

web the gutnick edition chumash the book of genesis with rashi s commentary targum onkelos and haftoras and commentary anthologized from classic rebbe english

the gutnick edition chumash book of genesis with r jps - Jan 26 2022

web the gutnick edition chumash book of genesis with r it is your no question own times to pretense reviewing habit accompanied by guides you could enjoy now is the

hardcover january 1 2003 amazon com - Feb 07 2023

web jan 1 2003 the gutnick edition chumash book of genesis with rashi s commentary targum onkelos and haftoras with a commentary anthologized from

[the authorized roy orbison the authorized biography abebooks](#) - Jan 28 2022

web this book co authored by roy orbison jr wesley orbison and alex orbison with jeff slate chronicles the making of roy orbison his personal life and his celebrity tennessean

the authorized roy orbison hachette book group - Feb 09 2023

web filled with hundreds of photographs many never before seen gathered from across the globe and uncovered from deep within the orbison vault the authorized roy orbison shows roy orbison as a young child and follows him all the way through to the peak of his stardom and up to his tragic end

the authorized roy orbison google books - May 12 2023

web oct 17 2017 filled with hundreds of photographs many never before seen gathered from across the globe and uncovered from deep within the orbison vault the authorized roy orbison shows roy orbison as a

[the authorized roy orbison by roy orbison wesley orbison](#) - Mar 30 2022

web oct 26 2017 synopsis for the first time legendary performer roy orbison s story as one of the most beloved rock legends will be revealed through family accounts and records roy orbison died 28 years ago but he s hardly forgotten

the authorized roy orbison the authorized biography - Jun 01 2022

web filled with hundreds of photographs many never before seen gathered from across the globe and uncovered from deep

within the orbison vault the authorized roy orbison shows roy orbison as a young child and follows him all the way through to the peak of his stardom and up to his tragic end

the authorized roy orbison alex orbison roy orbison - Dec 07 2022

web filled with hundreds of photographs many never before seen gathered from across the globe and uncovered from deep within the orbison vault the authorized roy orbison shows roy orbison as a young child and follows him all the way through to the peak of his stardom and up to his tragic end

the authorized roy orbison indigo books music inc - Apr 30 2022

web b for the first time legendary performer roy orbison s story as one of the most beloved rock legends will be revealed through family accounts and records b br br roy orbison is a rock and roll icon almost without peer he came of age as an artist on the venerable sun records label toured with the beatles had massive hits in the 1960s

the authorized roy orbison hardcover 28 november 2017 - Jan 08 2023

web nov 28 2017 paper cavalier us other sellers on amazon add to cart 345 00 8 82 delivery sold by university bookstore boston usa see all 2 images follow the author roy orbison the authorized roy orbison hardcover 28 november 2017 by roy orbison author wesley orbison author alex orbison author

the authorized roy orbison the authorized biography - Jul 02 2022

web the authorized roy orbison tells the epic tale of a west texas boy drawn to the guitar at age six whose monumental global career successes were matched at nearly every turn by extraordinary personal tragedies including the loss of his first wife in a motorcycle accident and his two oldest sons in a fire it s a story of the intense highs and

the authorized roy orbison hardcover oct 17 2017 amazon ca - Nov 06 2022

web oct 17 2017 filled with hundreds of photographs many never before seen gathered from across the globe and uncovered from deep within the orbison vault the authorized roy orbison shows roy orbison as a young child and follows him all the way through to the peak of his stardom and up to his tragic end

the authorized roy orbison the authorized biography - Oct 05 2022

web the authorized roy orbison tells the epic tale of a west texas boy drawn to the guitar at age six whose monumental global career successes were matched at nearly every turn by extraordinary personal tragedies including the loss of his first wife in a motorcycle accident and his two oldest sons in a fire

the authorized roy orbison bookshop uk - Sep 04 2022

web description for the first time legendary performer roy orbison s story as one of the most beloved rock legends will be revealed through family accounts and records roy orbison died 28 years ago but he s hardly forgotten

the authorized roy orbison the authorized biography - Jul 14 2023

web oct 26 2017 buy the authorized roy orbison the authorized biography by orbison jr roy orbison wesley orbison alex slate jeff isbn 9781478976547 from amazon s book store everyday low prices and free delivery on eligible orders

[the authorized roy orbison overdrive](#) - Feb 26 2022

web oct 17 2017 the authorized roy orbison tells the epic tale of a west texas boy drawn to the guitar at age six whose monumental global career successes were matched at nearly every turn by extraordinary personal tragedies including the loss of his first wife in a motorcycle accident and his two oldest sons in a fire

[the authorized roy orbison amazon co uk](#) - Mar 10 2023

web filled with hundreds of photographs many never before seen gathered from across the globe and uncovered from deep within the orbison vault the authorized roy orbison shows roy orbison as a young child and follows him all the way through to the peak of his stardom and up to his tragic end

the authorized roy orbison by alex orbison goodreads - Aug 03 2022

web jan 1 2017 for the first time legendary performer roy orbison s story as one of the most beloved rock legends is revealed through family accounts and records roy orbison died in 1988 but he s hardly forgotten

[the authorized roy orbison orbison alex orbison roy orbison](#) - Dec 27 2021

web the authorized roy orbison orbison alex orbison roy orbison wesley on amazon com au free shipping on eligible orders the authorized roy orbison

the authorized roy orbison roy orbison - Jun 13 2023

web oct 17 2017 the authorized roy orbison tells the epic tale of a west texas boy drawn to the guitar at age six whose monumental global career successes were matched at nearly every turn by extraordinary personal tragedies including the loss of his first wife in a motorcycle accident and his two oldest sons in a fire

the authorized roy orbison from roy orbison online store - Apr 11 2023

web the authorized roy orbison 30 00 or 4 payments of 7 50 sold out description by wesley roy jr alex orbison with jeff slate for the first time legendary performer roy orbison s story as one of the most beloved rock legends will be revealed through family accounts and records roy orbison is a rock and roll icon almost without peer

the authorized roy orbison amazon com - Aug 15 2023

web oct 17 2017 filled with hundreds of photographs many never before seen gathered from across the globe and uncovered from deep within the orbison vault the authorized roy orbison shows roy orbison as a young child and follows him all the way through to the peak of his stardom and up to his tragic end