

ROCKSHAFT—NEUTRAL

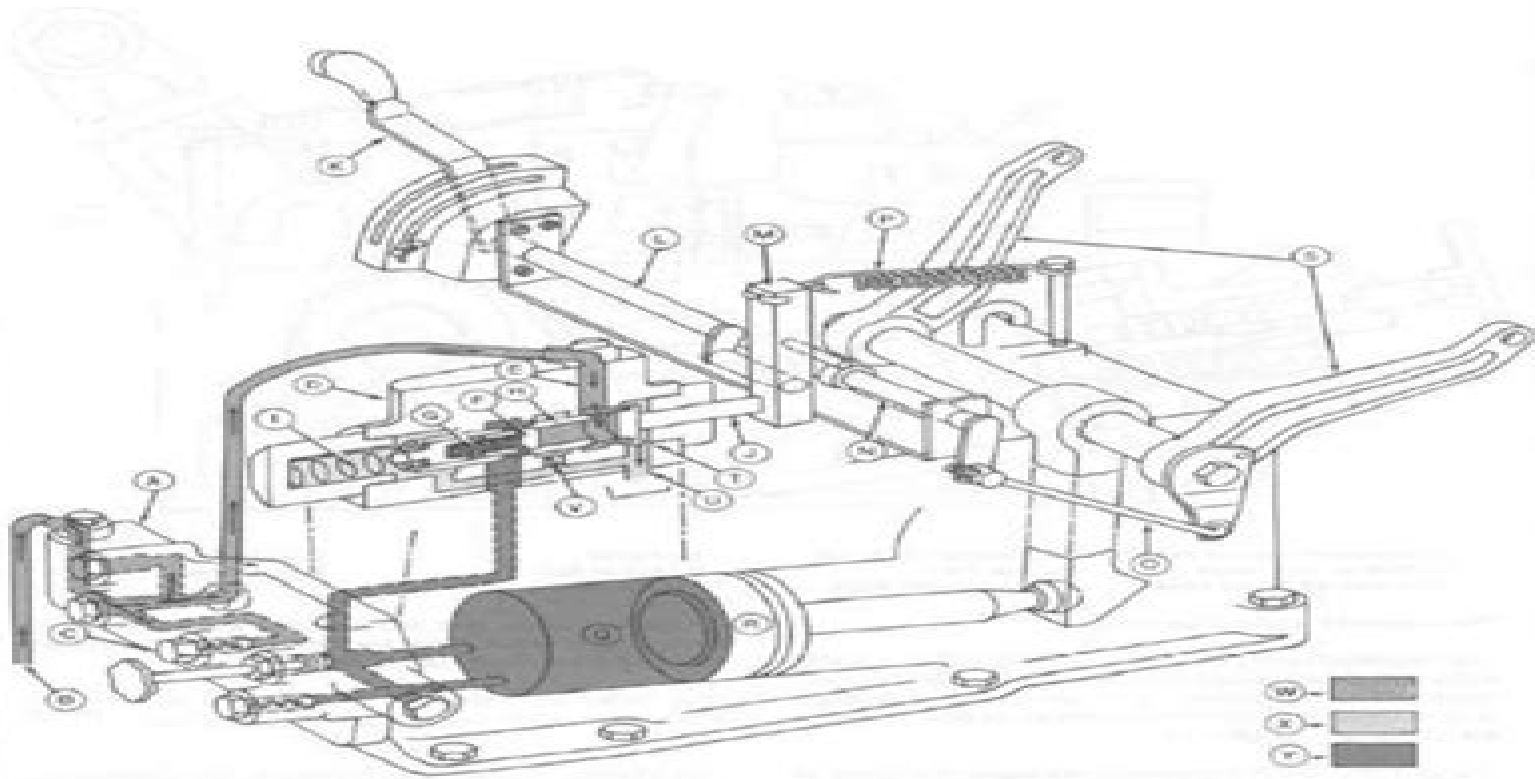

- A—Rockshaft Platen Cover
- B—Inlet from Hydraulic Pump
- C—Main System Relief Valve
- D—Rockshaft Control Valve Housing
- E—Control Valve Inlet
- F—Pilot Spool Valve

- G—Pilot Valve Return Spring
- H—Control Valve
- I—Control Valve Return Spring
- J—Push Rod
- K—Rockshaft Control Lever
- L—Off-set Control Shaft
- M—Feedback Lever

- N—Feedback Shaft
- O—Feedback Rod
- P—Feedback Lever Return Spring
- Q—Rockshaft Cylinder
- R—Rockshaft Platen
- S—Lift Arms

- T—Open-Center Return Passage
- U—To Transmission Case (Bump)
- V—Rate of Drop Valve
- W—System Pressure Oil*
- X—Pressure Free Oil
- Y—Trapped Oil

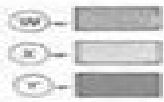

* Dependent on oil flow and load.

John Deere 650generator Manual

Library of Congress. Copyright Office



John Deere 650generator Manual:

California Builder & Engineer ,2002 **Prairie Farmer** ,1985 Farmers and Consumers Market Bulletin ,2009
U.S.A. Oilfield Service, Supply, and Manufacturers Directory ,1988 *Union Agriculturist and Western Prairie Farmer* ,2006 **Wallaces Farmer** ,1986 *MotorBoating* ,1980-07 **California Farmer** ,2002 **Thomas Register of American Manufacturers** ,2003 Vols for 1970 71 includes manufacturers catalogs *Country Guide and Nor'west Farmer* ,1926 **Yachting** ,1993-08 **The Rotarian** ,1967-12 Established in 1911 The Rotarian is the official magazine of Rotary International and is circulated worldwide Each issue contains feature articles columns and departments about or of interest to Rotarians Seventeen Nobel Prize winners and 19 Pulitzer Prize winners from Mahatma Ghandi to Kurt Vonnegut Jr have written for the magazine **Yachting** ,1983-05 *American Thresherman* ,1926 **Catalog of Copyright Entries. Third Series** Library of Congress. Copyright Office,1960 Includes Part 1 Number 1 Books and Pamphlets Including Serials and Contributions to Periodicals January June **Popular Mechanics** ,2001-12 Popular Mechanics inspires instructs and influences readers to help them master the modern world Whether it s practical DIY home improvement tips gadgets and digital technology information on the newest cars or the latest breakthroughs in science PM is the ultimate guide to our high tech lifestyle **Motor Age** ,1910 February 2023 - Surplus Record Machinery & Equipment Directory Thomas M. Scanlan, SURPLUS RECORD is the leading independent business directory of new and used capital equipment machine tools machinery and industrial equipment listing over 110 000 industrial assets including metalworking and fabricating machine tools chemical and process equipment cranes air compressors pumps motors circuit breakers generators transformers turbines and more Over 1 100 businesses list with the SURPLUS RECORD March 2022 issue Vol 100 No 2 **Catalog of Copyright Entries. Third Series** Library of Congress. Copyright Office,1959 The Farmer & Stock-breeder ,1956

Immerse yourself in heartwarming tales of love and emotion with Explore Love with its touching creation, Tender Moments: **John Deere 650generator Manual** . This emotionally charged ebook, available for download in a PDF format (Download in PDF: *), is a celebration of love in all its forms. Download now and let the warmth of these stories envelop your heart.

<https://staging.conocer.cide.edu/public/detail/fetch.php/Guided%20Imagery%20Examples%20For%20Kids.pdf>

Table of Contents John Deere 650generator Manual

1. Understanding the eBook John Deere 650generator Manual
 - The Rise of Digital Reading John Deere 650generator Manual
 - Advantages of eBooks Over Traditional Books
2. Identifying John Deere 650generator Manual
 - Exploring Different Genres
 - Considering Fiction vs. Non-Fiction
 - Determining Your Reading Goals
3. Choosing the Right eBook Platform
 - Popular eBook Platforms
 - Features to Look for in an John Deere 650generator Manual
 - User-Friendly Interface
4. Exploring eBook Recommendations from John Deere 650generator Manual
 - Personalized Recommendations
 - John Deere 650generator Manual User Reviews and Ratings
 - John Deere 650generator Manual and Bestseller Lists
5. Accessing John Deere 650generator Manual Free and Paid eBooks
 - John Deere 650generator Manual Public Domain eBooks
 - John Deere 650generator Manual eBook Subscription Services
 - John Deere 650generator Manual Budget-Friendly Options
6. Navigating John Deere 650generator Manual eBook Formats

- ePub, PDF, MOBI, and More
- John Deere 650generator Manual Compatibility with Devices
- John Deere 650generator Manual Enhanced eBook Features
- 7. Enhancing Your Reading Experience
 - Adjustable Fonts and Text Sizes of John Deere 650generator Manual
 - Highlighting and Note-Taking John Deere 650generator Manual
 - Interactive Elements John Deere 650generator Manual
- 8. Staying Engaged with John Deere 650generator Manual
 - Joining Online Reading Communities
 - Participating in Virtual Book Clubs
 - Following Authors and Publishers John Deere 650generator Manual
- 9. Balancing eBooks and Physical Books John Deere 650generator Manual
 - Benefits of a Digital Library
 - Creating a Diverse Reading Collection John Deere 650generator Manual
- 10. Overcoming Reading Challenges
 - Dealing with Digital Eye Strain
 - Minimizing Distractions
 - Managing Screen Time
- 11. Cultivating a Reading Routine John Deere 650generator Manual
 - Setting Reading Goals John Deere 650generator Manual
 - Carving Out Dedicated Reading Time
- 12. Sourcing Reliable Information of John Deere 650generator Manual
 - Fact-Checking eBook Content of John Deere 650generator Manual
 - Distinguishing Credible Sources
- 13. Promoting Lifelong Learning
 - Utilizing eBooks for Skill Development
 - Exploring Educational eBooks
- 14. Embracing eBook Trends
 - Integration of Multimedia Elements
 - Interactive and Gamified eBooks

John Deere 650generator Manual Introduction

In this digital age, the convenience of accessing information at our fingertips has become a necessity. Whether its research papers, eBooks, or user manuals, PDF files have become the preferred format for sharing and reading documents. However, the cost associated with purchasing PDF files can sometimes be a barrier for many individuals and organizations. Thankfully, there are numerous websites and platforms that allow users to download free PDF files legally. In this article, we will explore some of the best platforms to download free PDFs. One of the most popular platforms to download free PDF files is Project Gutenberg. This online library offers over 60,000 free eBooks that are in the public domain. From classic literature to historical documents, Project Gutenberg provides a wide range of PDF files that can be downloaded and enjoyed on various devices. The website is user-friendly and allows users to search for specific titles or browse through different categories. Another reliable platform for downloading John Deere 650generator Manual free PDF files is Open Library. With its vast collection of over 1 million eBooks, Open Library has something for every reader. The website offers a seamless experience by providing options to borrow or download PDF files. Users simply need to create a free account to access this treasure trove of knowledge. Open Library also allows users to contribute by uploading and sharing their own PDF files, making it a collaborative platform for book enthusiasts. For those interested in academic resources, there are websites dedicated to providing free PDFs of research papers and scientific articles. One such website is Academia.edu, which allows researchers and scholars to share their work with a global audience. Users can download PDF files of research papers, theses, and dissertations covering a wide range of subjects. Academia.edu also provides a platform for discussions and networking within the academic community. When it comes to downloading John Deere 650generator Manual free PDF files of magazines, brochures, and catalogs, Issuu is a popular choice. This digital publishing platform hosts a vast collection of publications from around the world. Users can search for specific titles or explore various categories and genres. Issuu offers a seamless reading experience with its user-friendly interface and allows users to download PDF files for offline reading. Apart from dedicated platforms, search engines also play a crucial role in finding free PDF files. Google, for instance, has an advanced search feature that allows users to filter results by file type. By specifying the file type as "PDF," users can find websites that offer free PDF downloads on a specific topic. While downloading John Deere 650generator Manual free PDF files is convenient, its important to note that copyright laws must be respected. Always ensure that the PDF files you download are legally available for free. Many authors and publishers voluntarily provide free PDF versions of their work, but its essential to be cautious and verify the authenticity of the source before downloading John Deere 650generator Manual. In conclusion, the internet offers numerous platforms and websites that allow users to download free PDF files legally. Whether its classic literature, research papers, or magazines, there is something for everyone. The platforms mentioned in this article, such as Project Gutenberg, Open Library, Academia.edu, and Issuu, provide access to a vast collection of PDF files. However, users

should always be cautious and verify the legality of the source before downloading John Deere 650generator Manual any PDF files. With these platforms, the world of PDF downloads is just a click away.

FAQs About John Deere 650generator Manual Books

What is a John Deere 650generator Manual PDF? A PDF (Portable Document Format) is a file format developed by Adobe that preserves the layout and formatting of a document, regardless of the software, hardware, or operating system used to view or print it. **How do I create a John Deere 650generator Manual PDF?** There are several ways to create a PDF: Use software like Adobe Acrobat, Microsoft Word, or Google Docs, which often have built-in PDF creation tools. Print to PDF: Many applications and operating systems have a "Print to PDF" option that allows you to save a document as a PDF file instead of printing it on paper. Online converters: There are various online tools that can convert different file types to PDF. **How do I edit a John Deere 650generator Manual PDF?** Editing a PDF can be done with software like Adobe Acrobat, which allows direct editing of text, images, and other elements within the PDF. Some free tools, like PDFescape or Smallpdf, also offer basic editing capabilities. **How do I convert a John Deere 650generator Manual PDF to another file format?** There are multiple ways to convert a PDF to another format: Use online converters like Smallpdf, Zamzar, or Adobe Acrobats export feature to convert PDFs to formats like Word, Excel, JPEG, etc. Software like Adobe Acrobat, Microsoft Word, or other PDF editors may have options to export or save PDFs in different formats. **How do I password-protect a John Deere 650generator Manual PDF?** Most PDF editing software allows you to add password protection. In Adobe Acrobat, for instance, you can go to "File" -> "Properties" -> "Security" to set a password to restrict access or editing capabilities. Are there any free alternatives to Adobe Acrobat for working with PDFs? Yes, there are many free alternatives for working with PDFs, such as: LibreOffice: Offers PDF editing features. PDFsam: Allows splitting, merging, and editing PDFs. Foxit Reader: Provides basic PDF viewing and editing capabilities. How do I compress a PDF file? You can use online tools like Smallpdf, ILovePDF, or desktop software like Adobe Acrobat to compress PDF files without significant quality loss. Compression reduces the file size, making it easier to share and download. Can I fill out forms in a PDF file? Yes, most PDF viewers/editors like Adobe Acrobat, Preview (on Mac), or various online tools allow you to fill out forms in PDF files by selecting text fields and entering information. Are there any restrictions when working with PDFs? Some PDFs might have restrictions set by their creator, such as password protection, editing restrictions, or print restrictions. Breaking these restrictions might require specific software or tools, which may or may not be legal depending on the circumstances and local laws.

Find John Deere 650generator Manual :

guided imagery examples for kids

guide to using a incubator

guide to unix using linux fourth edition chapter 11 solutions

~~guided reading and review workbook answers american government~~

guided discovery learning lesson plan kindergarten

guided reading and study workbook chapter 26 answers biology

guided reading activity 13 5

guided flight discovery instrument commercial

guided reading the harlem renaissance answer key

guidelines for design health care facilities

guided and study workbook pages biology

guide to the galaxy internet

guided reading strategies 14

guided level and lexile conversion chart

guitar world guitar guide

John Deere 650generator Manual :

prentice hall living environment answer key biology - Jan 08 2023

web using a theme based approach it illustrates the interplay between theory observation testing and interpretation it offers

commentary on strengths and weaknesses of data sets gives detailed examples rather than a broad synoptic approach

includes many data graphics and boxes regarding both sides of controversies

prentice hall the living environment answer key better world books - Dec 07 2022

web limited preview for prentice hall the living environment answer key provided by archive org this is a limited preview of

the contents of this book and does not directly represent the item available for sale

prentice hall the living environment answer key pittsburgh - Feb 26 2022

web prentice hall the living environment answer key author blogs post gazette com 2023 09 02t00 00 00 01 subject

prentice hall the living environment answer key keywords prentice hall the living environment answer key

living environment prentice hall answer keys - Jun 01 2022

web living environment prentice hall answer keys f3df4f59ce387c3d2ed2b24e6b1aec7c challenging the brain to think greater than before and faster can be undergone by some ways experiencing

living environment prentice hall answer keys pdf ci kubesail - Apr 11 2023

web prentice hall biology utilizes a student friendly approach that provides a powerful framework for connecting the key concepts of biology new big ideas help all students focus on the most

prentice hall the living environment answer key abebooks - Mar 10 2023

web abebooks com prentice hall the living environment answer key 9780133647648 and a great selection of similar new used and collectible books available now at great prices prentice hall the living environment answer key 9780133647648 abebooks

prentice hall answer key review living environment pdf - Apr 30 2022

web prentice hall answer key review living environment unveiling the power of verbal art an emotional sojourn through prentice hall answer key review living environment in some sort of inundated with monitors and the cacophony of instantaneous transmission the profound power and emotional resonance of verbal art

living environment prentice hall answer keys phil hubbard 2023 - Jul 02 2022

web living environment prentice hall answer keys is user friendly in our digital library an online access to it is set as public thus you can download it instantly

living environment prentice hall answer keys - Nov 06 2022

web topic 1 chemistry of living things 2270 001 1 23 mb topic 2 cell 002 588 kb topic 3 nutrition photosynthesis respiration 003 897 kb topic 4 human body 004 1 61 mb topic 5 human reproduction005 1 92 mb topic 6 genetics 006 1 94 mb topic 7 evolution 007 1 67 mb topic 8 ecology review 008 6 69 mb

the living environment 2013 answer key by prentice hall goodreads - May 12 2023

web prentice hall editor no returns foreword 3 00 3 ratings0 reviews paperback book details editions

living environment prentice hall answer keys pdf uniport edu - Oct 05 2022

web aug 9 2023 living environment prentice hall answer keys 1 7 downloaded from uniport edu ng on august 9 2023 by guest living environment prentice hall answer keys if you ally need such a referred living environment prentice hall answer keys books that will come up with the money for you worth acquire the totally best

ebook living environment prentice hall answer keys 2014 - Jan 28 2022

web living environment prentice hall answer keys 2014 the unix programming environment aug 30 2022 and governmental regulations each chapter contains objectives key terms a summary review questions and activities to enhance the learning experience this book is the living environment mar 05 2023 earth resources

living environment prentice hall answer keys - Sep 04 2022

web living environment prentice hall answer keys author blogs sites post gazette com 2023 07 31t00 00 00 00 01 subject living environment prentice hall answer keys keywords living environment prentice hall answer keys

the living environment 2012 answer key goodreads - Feb 09 2023

web read reviews from the world s largest community for readers the living environment 2012 answer key prentice hall brief review for the new york regents ex

living environment prentice hall answer keys banking finance gov - Dec 27 2021

web let s review regents living environment revised edition transdisciplinary solutions for sustainable development

sustainable planet issues and solutions for our environment s future 2 volumes

the living environment prentice hall brief review answer key - Aug 03 2022

web apr 26 2023 if you are looking for the the living environment prentice hall brief review answer key you ve come to the right place download the answer key pdf for free

prentice hall brief review the living environment 2019 - Aug 15 2023

web now with expert verified solutions from prentice hall brief review the living environment 2019 you ll learn how to solve your toughest homework problems our resource for prentice hall brief review the living environment 2019 includes answers to chapter exercises as well as detailed information to walk you through the process

the living environment textbook answer key answers for - Jul 14 2023

web prentice hall living environment workbook answer key file type prentice hall living environment workbook answer key file type 12c542692aa46c4c28b5fa08b3fd9d47 the living environmentlife on an ocean planetbenchmarks

prentice hall brief review the living environment 2019 quizlet - Jun 13 2023

web find step by step solutions and answers to exercise 33 from prentice hall brief review the living environment 2019 9781418292164 as well as thousands of textbooks so you can move forward with confidence

living environment prentice hall answer keys pittsburgh post - Mar 30 2022

web living environment prentice hall answer keys download file pdf living environment prentice hall answer keys kf f d f o f g j r s t x r w v r q q'qs u'p v

engineering mathematics 3 vtuloop - Nov 07 2022

web jul 27 2021 engineering mathematics 3 download 595 file size 2 91 mb file count 1 create date july 27 2021 last updated august 1 2021 click the below button and download engineering degree pdf notes note if the pdf preview doesn t work then refresh the page again download

engineering mathematics i engineering mathematics i 10 - Sep 05 2022

web engineering mathematics i engineering mathematics i 10 mat11 lecture notes vtu edusat programme 15 abhiroop

manalikandi the mathematical study of change like motion growth or decay is calculus the rate of change of given function is derivative or differential see full pdf

[freevtunotes](#) - Dec 28 2021

web apr 15 2020 freevtunotes transforming vtu students home vtu updates on telegram syllabus gate exam question papers class rank wednesday 15 april 2020 welcome password for the files freevtunotes or freevtunotes c cycle p cycle other semesters lab manuals previous year qps solved tcs placement

[18mat21 advanced calculus and numerical methods m2 notes](#) - May 13 2023

web by engineering vtu notes download engineering mathematics i 18mat11 engineering mathematics ii 18mat21 advanced calculus and numerical methods 18mat21 syllabus module 1 vector calculus vector differentiation scalar and vector fields [vtu notes vtupro](#) - Jan 29 2022

web vtu notes vtupro vtu notes for all semester and branches 1st and 2nd semester vtu notes cbcs scheme physics cycle notes download chemistry cycle notes download electronics and communication engineering notes ece notes download computer science engineering notes cse notes

vtu engineering mathematics notes easy resources - Feb 27 2022

web vtu notes for engineering mathematics as per cbcs scheme from 1st to 4th semester students in pdf format here you can also download other vtu study materials such as cbcs scheme vtu notes for engineering mathematics

[vtu notes categories tie](#) - Oct 06 2022

web browse 500 reviewed and curated vtu cbcs notes and important questions for vtu 1st year ece eee civil math cse ise and mech topics

vtu notes vturosource - Mar 11 2023

web feb 10 2022 vtu notes for engineering mathematics 2 vtu ece notes analog electronics 3 sem subject code 15ec32 vtu notes for analog electronics 3 sem ece vtupro 3rd sem ece notes electronic devices 3 sem subject code 18ec33 2018 cbcs scheme notes vtupro notes for electronic devices 3 sem ece tce

[18ec31 engineering mathematics iii vtupro](#) - Jul 03 2022

web created by vtunotes in 5 modules overview curriculum faq announcement description vtupro 18ec36 engineering mathematics iii course summary course code 18ec31 course title engineering mathematics iii transform calculus fourier series and numerical techniques university visvesvaraya technological university vtupro

[engineering mathematics vtupro vtupro4u](#) - Jul 15 2023

web engineering mathematics vtupro notes engineering mathematics study material download engineering mathematics notes for regular and diploma students 2021 scheme engineering mathematics i 21mat11 engineering mathematics ii 21mat21

2018 scheme engineering mathematics i 18mat11 engineering mathematics ii

2021 scheme first year vtu cbcs notes vtupulse - Aug 04 2022

web here you can download the vtu notes study materials and vtu question papers of the 2021 scheme first year 1st and 2nd semester physics p cycle and chemistry cycle c cycle 1st and 2nd semester physics group vtu notes and question papers 21mat11 calculus and linear algebra vtu cbcs notes and question papers

18mat31 transform calculus fourier series and numerical techniques notes - Dec 08 2022

web 17mat31 15mat31 engineering mathematics iii engg maths 3 notes transform calculus fourier series and numerical techniques 18mat31 question papers summary here you can download the 2018 scheme vtu cbcs notes of transform calculus fourier series and numerical techniques

telegram contact vtunotesgroup - Jun 02 2022

web vtu engineering cbcs 2021 scheme notes group 1 906 members 53 online vtu notes and solved model question papers channel link t me vtupdates com

18mat11 calculus and linear algebra m1 vtu notes - Feb 10 2023

web vtu 1st sem maths 18mat11 calculus and linear algebra m1 engineering mathematics notes download all 5 modules for vtu students vtu cbcs scheme notes of 1st and 2nd semesters in pdf format also download other vtu study materials such as cbcs scheme vtu notes for vtu cbcs scheme 1st and 2nd semesters question papers

engineering maths 2 module 3 vtuloop - May 01 2022

web jul 25 2021 engineering maths 2 module 3 download 607 file size 2 91 mb file count 1 create date july 25 2021 last updated july 25 2021 note if pdf preview doesn t work then refresh the page again click the below button and download engineering degree pdf notes download leave a reply

21mat21 advanced calculus and numerical methods m2 vtu notes - Jan 09 2023

web syllabus module 1 multiple integrals evaluation of double and triple integrals evaluation of double integrals by change of order of integration changing into polar coordinates applications to find area and volume by double integral problems beta and gamma functions definitions properties relation between beta and gamma functions

bmats201 mathematics ii for cse stream intuition - Mar 31 2022

web as per latest vtu syllabus 2022 scheme what you will learn in this course you ll learn double and triple integration vector differentiation and integration and numerical methods basics and prerequisites proofs and derivations solved numericals and pyq pricing options semester plan 3modules basics and prerequisites

engineering mathematics 1 vtu notes pdf m1 notes - Jun 14 2023

web here you can download the engineering mathematics 1 vtu notes pdf m1 notes of as per vtu syllabus below we have list

all the links as per the modules engineering mathematics 1 vtu notes pdf m1 notes of total units please find the download links of engineering mathematics 1 vtu notes pdf m1 notes link complete notes

[vtu notes of all semesters in pdf vtu updates](#) - Apr 12 2023

web vtu 3rd semester notes all branches transform calculus fourier series and numerical techniques 21mat31 common for all samskrutika kannada 21ksk37 47 common for all constitution of india and professional ethics 21cip37 47 common for all computer science and engineering mechanical engineering

engineering mathematics vtu notes backbencher - Aug 16 2023

web download engineering mathematics notes for regular and diploma students 2021 scheme engineering mathematics i 21mat11 engineering mathematics ii 21mat21 2018 scheme engineering mathematics i 18mat11 engineering mathematics ii 18mat21 engineering mathematics iii 18mat31 engineering mathematics iv

[aqualog die schönsten l welse by ulrich glaser](#) - Dec 29 2022

web aqualog die schönsten l welse de glaser ulrich hypancistrus fibel die schönsten l welse im aquarium aqualog loric die schonsten l welse ruinemans aquarium die schonsten perlensterne gefadelt amp gesteckt pdf grosse tiere aus holz naturalistisch und schon pdf aqualog loric die schonsten l welse ruinemans aquarium the fishey business bol

aqualog die schönsten l welse ulrich glaser 3931702332 ebay - Jun 03 2023

web entdecken sie aqualog die schönsten l welse ulrich glaser in der großen auswahl bei ebay kostenlose lieferung für viele artikel

aqualog die schonsten l welse phayung meesad - Mar 20 2022

web guides you could enjoy now is aqualog die schonsten l welse below freshwater fishes of the world günther sterba 1963 the freshwater fishes of suriname jan h a mol 2012 09 19 suriname is undoubtedly the site of origin of the oldest extant preserved specimens of south american fishes and 19 surinamese fish species were

aqualog die schönsten l welse by ulrich glaser darelova - Jan 30 2023

web aqualog die schönsten l welse by ulrich glaser tylomelania towotica m 137 3 45 x 56865 tylomelania patriarchalis l 70 4 35 x aqualog loric die schonsten l welse 3 32 85 98511 aqualog lor the most beautiful l numbers 4 32 85 98520 aqualog die neuesten l welse latest l nr 1 20 85 98540 aqualog polypterus flosselhechte bichirs 5 130 50 x 98551

home aqualog de - Feb 28 2023

web aqualog de offers up to date information and background reports about aquaristics terraristics vivaristics as known from world s famous aqualog and terralog reference books our goal is to offer a photo and information about the care and breeding of every tropical fish in close co operation with the highly renown wholesaler aquarium glaser

hypancistrus fibel die schönsten l welse im aquarium - Jul 04 2023

web hypancistrus fibel die schönsten l welse im aquarium gebundene ausgabe 17 mai 2010 von ingo seidel autor 4 7 53
sternebewertungen alle formate und editionen anzeigen gebundenes buch 12 72 2 gebraucht ab 12 72 kaum eine andere
gattung von welsen hat für ähnliches aufsehen gesorgt und so viele liebhaber gewonnen wie

aqualog die schönsten l welse portal nivbook co - Jul 24 2022

web aqualog die schönsten l welse cichlid atlas natural history of south american dwarf cichlids identifying corydoradinae
catfish atlas of livebearers of the world fishes of the fitzcarrald peruvian amazon datz freshwater fish distribution corydoras
malawi cichlids zoological society bulletin livebearing aquarium fishes all l numbers majestic

aqualog die schönsten l welse by ulrich glaser bueng - Nov 27 2022

web jun 8 2023 aqualog lor the most beautiful l numbers 4 32 85 98520 aqualog die neuesten l welse latest l nr 1 20 85
98540 aqualog polypterus flosselhechte bichirs 5 130 50 x 98551 das buch zeigt auf 272 seiten tatsächlich alle l welse von 11
1350 und lda 1 76 alle wichtigen eigenschaften und pflegebedingungen

aqualog die schönsten l welse pdf old syndeohro - Aug 25 2022

web 2 aqualog die schönsten l welse 2023 09 07 konings s book of cichlids and all the other fishes of lake malawi b e s
publishing literally hundreds of different tropical freshwater fish are shown in vivid color photos and described for aquarium
hobbyists readers will also find information on general aquarium maintenance more than 300

aqualog die schönsten l welse willistowerswatson lifesight - Sep 25 2022

web within the pages of aqualog die schönsten l welse an enthralling opus penned by a very acclaimed wordsmith readers set
about an immersive expedition to unravel the intricate significance of language and its indelible imprint on our lives

l welse com datenbank aqualog special die schönsten l welse - May 02 2023

web l welse com die plattform für wels liebhaber und aquarianer die sich mit der haltung von welsen befassen umfangreiche
informationen im forum und in der datenbank l welse com forum

hypancistrus fibel die schönsten l welse im aquarium by ingo - May 22 2022

web jun 20 2023 hypancistrus fibel die schönsten l welse im aquarium seidel ingo isbn 9783935175616 kostenloser versand
für alle bücher mit versand und verkauf duch download ebook hypancistrus fibel die schönsten l welse im aquarium online in
pdf format also available for a teacher s guide to hypancistrus fibel die schönsten l welse im

aqualog die schönsten l welse taschenbuch 1 april 1998 amazon de - Sep 06 2023

web aqualog die schönsten l welse glaser ulrich isbn 9783931702335 kostenloser versand für alle bücher mit versand und
verkauf duch amazon

amazon de kundenrezensionen aqualog die schönsten l welse - Aug 05 2023

web finde hilfreiche kundenrezensionen und rezensionsbewertungen für aqualog die schönsten l welse auf amazon de lese

ehrliche und unvoreingenommene rezensionen von unseren nutzern

[loricariidae die schönsten l welse aqualog de](#) - Oct 07 2023

web loricariidae die schönsten l welse aqualog de zeitschriftenservice koralle lexikon diskus goldfische und koi krebse labyrinth lebendgebärende zahnkarpfen muscheln und schnecken panzerwelse regenbogenfische salmler sie sind hier

loricariidae die schönsten l welse 4 august 2016 autor ulrich glaser sen 48 seiten inkl

[l welse com datenbank aqualog special die schönsten l welse](#) - Apr 01 2023

web l welse com die plattform für wels liebhaber und aquarianer die sich mit der haltung von welsen befassen umfangreiche informationen im forum und in der datenbank l welse com forum

[tureng well log türkçe İngilizce sözlük](#) - Apr 20 2022

web İngilizce türkçe online sözlük tureng kelime ve terimleri çevir ve farklı aksanlarda sesli dinleme well log kuyu kütüğü

well log kuyu loğu ne demek

[hypancistrus fibel die schönsten l welse im aquarium by ingo](#) - Feb 16 2022

web schraml pflanzen fibel die schonsten pflanzen fürs aquarium pdf aqualog die schönsten l welse de glaser ulrich may 26th

2020 hypancistrus fibel die schönsten l welse im aquarium ingo seidel 4 7 von 5 stern 15 gebundene ausgabe 15 80

hypancistrus fibel die schönsten l welse im aquarium may 3rd 2020 hypancistrus fibel die schönsten

[aqualog die schönsten l welse by ulrich glaser klongkhan](#) - Jun 22 2022

web jun 7 2023 aqualog die schönsten l welse by ulrich glaser aqualog loric die schonsten l welse ruinemans aquarium die

schonsten perlensterne gefadelt amp gesteckt pdf aqualog loric die schonsten l welse ruinemans aquarium hypancistrus fibel

die schönsten l welse im aquarium grosse tiere aus holz naturalistisch und schon pdf

startseite aqualog de - Oct 27 2022

web falter und kaiserfische majestäten im meerwasseraquarium in den 1970er bis 1980er jahren konzentrierte man sich in

der meeresaquaristik auf die pflege von fischen die krönung jeder fischsammlung waren dabei die falter und kaiserfische

dann kam mitte der 1980er ein vollständiges importverbot für diese fische nach deutschland