

# BRACKETS AND MOUNTING ACCESSORIES

## FLOODLIGHTING BRACKETS, STEEL BULLHORN

Floodlighting bracket steel bullhorn for pole with 2-3/8 in. or 4 in. OD top tenon. Bracket has 2-3/8 in. top OD and is prime pointed.

### BRACKET SELECTION TABLE

Number/ Placement Tenons	See Fig.	Recommended Size of Each Luminaire		Ordering Number	Adjacent Tenon Spacing A (in.)	Luminaire Mounting OD (in.)	Bracket Size	
		Max Weight (lbs)	Max EPA (sq ft)				Weight (lbs)	EPA (sq ft)
<b>BRACKETS TO FIT POLES HAVING 2-3/8 IN. OD TOP TENON</b>								
2 in line	2a	100	5.0	FBSB2B2TTPP	36	2-3/8	21	1.0
3 in line	2b	100	3.8	FBSB2C2TTPP	50	2-3/8	32	1.6
4 in line	2c	100	3.0	FBSB2D2TTPP	30	2-3/8	44	2.3
3 at 120°	2d	100	3.8	FBSB2E2TTPP	41	2-3/8	34	1.3
4 at 90°	2e	100	3.0	FBSB2F2TTPP	34	2-3/8	44	1.6
<b>BRACKETS TO FIT POLES HAVING 4 IN. OD TOP TENON</b>								
3 in line	3a	125	6.0	FBSB4C2TTPP	36	2-3/8	37	1.9
4 in line	3c	125	6.0	FBSB4D2TTPP	36	2-3/8	67	2.6
3 at 120°	3d	125	6.0	FBSB4E2TTPP	41	2-3/8	38	1.5
4 at 90°	3e	125	6.0	FBSB4F2TTPP	34	2-3/8	48	1.6

NOTE: All brackets are prime pointed. For galvanized brackets, substitute **GV** for **PP** in ordering number listed in Selection Table.

## ROADWAY BRACKETS, STEEL UPSWEEP AND STRAIGHT FOR 2-3/8 IN. OD POLE TOP TENONS

Roadway bracket steel upswEEP or straight, for poles with 2-3/8 in. OD pole top tenons. Bracket has 2-3/8 in. OD and is prime pointed.

### BRACKET SELECTION TABLE

Number/ Placement Tenons	See Fig.	Bracket Dimensions		Recommended Size of Each Luminaire		Ordering Number	Luminaire Mounting OD (in.)	Bracket Size	
		A (ft)	B (in.)	Max Weight (lbs)	Max EPA (sq ft)			Weight (lbs)	EPA (sq ft)
<b>STEEL UPSWEEP BRACKET FOR 2-3/8 IN. OD TOP TENON</b>									
1	2a	6	24	75	2.0	RBSU2H6PP	2-3/8	29	1.5
2 at 180°	2b	6	24	75	2.0	RBSU2J6PP	2-3/8	54	2.8
3 at 120°	2c	6	24	75	2.0	RBSU2K6PP	2-3/8	76	1.8
4 at 90°	2d	6	24	75	2.0	RBSU2L6PP	2-3/8	99	2.9
<b>STEEL STRAIGHT BRACKET FOR 2-3/8 IN. OD TOP TENON</b>									
1	3a	2	5	125	6.0	RBS52H2PP	2-3/8	12	0.6
2 at 180°	3b	2	5	125	6.0	RBS52J2PP	2-3/8	18	1.0
3 at 120°	2c	2	5	125	6.0	RBS52K2PP	2-3/8	26	1.0
4 at 90°	2d	2	5	125	6.0	RBS52L2PP	2-3/8	32	1.4

NOTE: All brackets are prime pointed. For galvanized brackets, substitute **GV** for **PP** in ordering number listed in Selection Table.

Figure 1

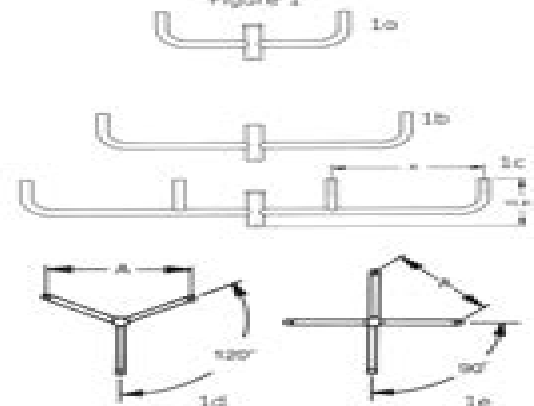

Figure 2

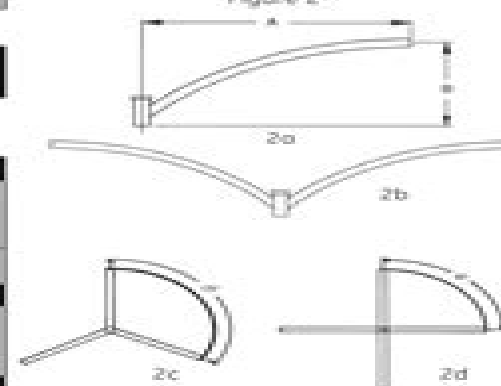

Figure 3



# Ge Landscape Lighting User Manual

**R Barnett**



## **Ge Landscape Lighting User Manual:**

Delve into the emotional tapestry woven by Crafted by in Experience **Ge Landscape Lighting User Manual** . This ebook, available for download in a PDF format ( PDF Size: \*), is more than just words on a page; itis a journey of connection and profound emotion. Immerse yourself in narratives that tug at your heartstrings. Download now to experience the pulse of each page and let your emotions run wild.

<https://staging.conocer.cide.edu/public/uploaded-files/HomePages/makeinq%20practice%20fun%2025%20hidden%20message.pdf>

## **Table of Contents Ge Landscape Lighting User Manual**

1. Understanding the eBook Ge Landscape Lighting User Manual
  - The Rise of Digital Reading Ge Landscape Lighting User Manual
  - Advantages of eBooks Over Traditional Books
2. Identifying Ge Landscape Lighting User Manual
  - Exploring Different Genres
  - Considering Fiction vs. Non-Fiction
  - Determining Your Reading Goals
3. Choosing the Right eBook Platform
  - Popular eBook Platforms
  - Features to Look for in an Ge Landscape Lighting User Manual
  - User-Friendly Interface
4. Exploring eBook Recommendations from Ge Landscape Lighting User Manual
  - Personalized Recommendations
  - Ge Landscape Lighting User Manual User Reviews and Ratings
  - Ge Landscape Lighting User Manual and Bestseller Lists
5. Accessing Ge Landscape Lighting User Manual Free and Paid eBooks
  - Ge Landscape Lighting User Manual Public Domain eBooks
  - Ge Landscape Lighting User Manual eBook Subscription Services

- Ge Landscape Lighting User Manual Budget-Friendly Options
- 6. Navigating Ge Landscape Lighting User Manual eBook Formats
  - ePub, PDF, MOBI, and More
  - Ge Landscape Lighting User Manual Compatibility with Devices
  - Ge Landscape Lighting User Manual Enhanced eBook Features
- 7. Enhancing Your Reading Experience
  - Adjustable Fonts and Text Sizes of Ge Landscape Lighting User Manual
  - Highlighting and Note-Taking Ge Landscape Lighting User Manual
  - Interactive Elements Ge Landscape Lighting User Manual
- 8. Staying Engaged with Ge Landscape Lighting User Manual
  - Joining Online Reading Communities
  - Participating in Virtual Book Clubs
  - Following Authors and Publishers Ge Landscape Lighting User Manual
- 9. Balancing eBooks and Physical Books Ge Landscape Lighting User Manual
  - Benefits of a Digital Library
  - Creating a Diverse Reading Collection Ge Landscape Lighting User Manual
- 10. Overcoming Reading Challenges
  - Dealing with Digital Eye Strain
  - Minimizing Distractions
  - Managing Screen Time
- 11. Cultivating a Reading Routine Ge Landscape Lighting User Manual
  - Setting Reading Goals Ge Landscape Lighting User Manual
  - Carving Out Dedicated Reading Time
- 12. Sourcing Reliable Information of Ge Landscape Lighting User Manual
  - Fact-Checking eBook Content of Ge Landscape Lighting User Manual
  - Distinguishing Credible Sources
- 13. Promoting Lifelong Learning
  - Utilizing eBooks for Skill Development
  - Exploring Educational eBooks
- 14. Embracing eBook Trends

- Integration of Multimedia Elements
- Interactive and Gamified eBooks

### **Ge Landscape Lighting User Manual Introduction**

Free PDF Books and Manuals for Download: Unlocking Knowledge at Your Fingertips In today's fast-paced digital age, obtaining valuable knowledge has become easier than ever. Thanks to the internet, a vast array of books and manuals are now available for free download in PDF format. Whether you are a student, professional, or simply an avid reader, this treasure trove of downloadable resources offers a wealth of information, conveniently accessible anytime, anywhere. The advent of online libraries and platforms dedicated to sharing knowledge has revolutionized the way we consume information. No longer confined to physical libraries or bookstores, readers can now access an extensive collection of digital books and manuals with just a few clicks. These resources, available in PDF, Microsoft Word, and PowerPoint formats, cater to a wide range of interests, including literature, technology, science, history, and much more. One notable platform where you can explore and download free Ge Landscape Lighting User Manual PDF books and manuals is the internet's largest free library. Hosted online, this catalog compiles a vast assortment of documents, making it a veritable goldmine of knowledge. With its easy-to-use website interface and customizable PDF generator, this platform offers a user-friendly experience, allowing individuals to effortlessly navigate and access the information they seek. The availability of free PDF books and manuals on this platform demonstrates its commitment to democratizing education and empowering individuals with the tools needed to succeed in their chosen fields. It allows anyone, regardless of their background or financial limitations, to expand their horizons and gain insights from experts in various disciplines. One of the most significant advantages of downloading PDF books and manuals lies in their portability. Unlike physical copies, digital books can be stored and carried on a single device, such as a tablet or smartphone, saving valuable space and weight. This convenience makes it possible for readers to have their entire library at their fingertips, whether they are commuting, traveling, or simply enjoying a lazy afternoon at home. Additionally, digital files are easily searchable, enabling readers to locate specific information within seconds. With a few keystrokes, users can search for keywords, topics, or phrases, making research and finding relevant information a breeze. This efficiency saves time and effort, streamlining the learning process and allowing individuals to focus on extracting the information they need. Furthermore, the availability of free PDF books and manuals fosters a culture of continuous learning. By removing financial barriers, more people can access educational resources and pursue lifelong learning, contributing to personal growth and professional development. This democratization of knowledge promotes intellectual curiosity and empowers individuals to become lifelong learners, promoting progress and innovation in various fields. It is worth noting that while accessing free Ge Landscape Lighting User Manual PDF books and manuals is convenient and cost-effective, it is vital

to respect copyright laws and intellectual property rights. Platforms offering free downloads often operate within legal boundaries, ensuring that the materials they provide are either in the public domain or authorized for distribution. By adhering to copyright laws, users can enjoy the benefits of free access to knowledge while supporting the authors and publishers who make these resources available. In conclusion, the availability of Ge Landscape Lighting User Manual free PDF books and manuals for download has revolutionized the way we access and consume knowledge. With just a few clicks, individuals can explore a vast collection of resources across different disciplines, all free of charge. This accessibility empowers individuals to become lifelong learners, contributing to personal growth, professional development, and the advancement of society as a whole. So why not unlock a world of knowledge today? Start exploring the vast sea of free PDF books and manuals waiting to be discovered right at your fingertips.

### FAQs About Ge Landscape Lighting User Manual Books

**What is a Ge Landscape Lighting User Manual PDF?** A PDF (Portable Document Format) is a file format developed by Adobe that preserves the layout and formatting of a document, regardless of the software, hardware, or operating system used to view or print it. **How do I create a Ge Landscape Lighting User Manual PDF?** There are several ways to create a PDF: Use software like Adobe Acrobat, Microsoft Word, or Google Docs, which often have built-in PDF creation tools. Print to PDF: Many applications and operating systems have a "Print to PDF" option that allows you to save a document as a PDF file instead of printing it on paper. Online converters: There are various online tools that can convert different file types to PDF. **How do I edit a Ge Landscape Lighting User Manual PDF?** Editing a PDF can be done with software like Adobe Acrobat, which allows direct editing of text, images, and other elements within the PDF. Some free tools, like PDFescape or Smallpdf, also offer basic editing capabilities. **How do I convert a Ge Landscape Lighting User Manual PDF to another file format?** There are multiple ways to convert a PDF to another format: Use online converters like Smallpdf, Zamzar, or Adobe Acrobats export feature to convert PDFs to formats like Word, Excel, JPEG, etc. Software like Adobe Acrobat, Microsoft Word, or other PDF editors may have options to export or save PDFs in different formats. **How do I password-protect a Ge Landscape Lighting User Manual PDF?** Most PDF editing software allows you to add password protection. In Adobe Acrobat, for instance, you can go to "File" -> "Properties" -> "Security" to set a password to restrict access or editing capabilities. Are there any free alternatives to Adobe Acrobat for working with PDFs? Yes, there are many free alternatives for working with PDFs, such as: LibreOffice: Offers PDF editing features. PDFsam: Allows splitting, merging, and editing PDFs. Foxit Reader: Provides basic PDF viewing and editing capabilities. How do I compress a PDF file? You can use online tools like Smallpdf, ILovePDF, or desktop software like Adobe Acrobat to compress PDF files without significant quality loss.

Compression reduces the file size, making it easier to share and download. Can I fill out forms in a PDF file? Yes, most PDF viewers/editors like Adobe Acrobat, Preview (on Mac), or various online tools allow you to fill out forms in PDF files by selecting text fields and entering information. Are there any restrictions when working with PDFs? Some PDFs might have restrictions set by their creator, such as password protection, editing restrictions, or print restrictions. Breaking these restrictions might require specific software or tools, which may or may not be legal depending on the circumstances and local laws.

### **Find Ge Landscape Lighting User Manual :**

[makeing practice fun 25 hidden message](#)

[maicirctriser largumentation cursus](#)

**magnavox repair user guide**

**maico ma 25 service manual**

[magnavox mrv700vr manual](#)

[maintenance and service guide de hp pour les dv8000](#)

[magruder s american government c 2007 answers](#)

[mahomet ou mouhammad](#)

[make custom xbox 36guide button](#)

**main topics paper1 in agricultural science grade11**

[magnetic drill guide](#)

[magnavox zv457mg9 a manual](#)

~~[magruder39s american government guided reading and review workbook answers](#)~~

[make stick figure with text message](#)

**magruders civil rights study guide**

### **Ge Landscape Lighting User Manual :**

Molecular Biology 5th Edition Textbook Solutions Access Molecular Biology 5th Edition solutions now. Our solutions are written by Chegg experts so you can be assured of the highest quality! Molecular Biology (5th Ed) Weaver is the divisional dean for the science and mathematics departments within the College, which includes supervising 10 different departments and programs. Molecular Biology 5th Edition - Chapter 20 Solutions Access Molecular Biology 5th Edition Chapter 20



solutions now. Our solutions are written by Chegg experts so you can be assured of the highest quality!

Molecular Biology: 9780073525327: Weaver, Robert: Books Molecular Biology, 5/e by Robert Weaver, is designed for an introductory course in molecular biology. Molecular Biology 5/e focuses on the fundamental concepts ... Test Bank For Molecular Biology 5th Edition Robert Weaver 1. An experiment was designed to obtain nonspecific transcription from both strands of a DNA molecule. Which of the following strategies would be most ... Molecular Biology, 5th Edition [5th&nbsp;ed.] 0073525324, ... Molecular Biology, 4/e by Robert Weaver, is designed for an introductory course in molecular biology. Molecular Biology... Molecular Biology 5th edition 9780071316866 Molecular Biology 5th Edition is written by Robert Weaver and published by McGraw-Hill International (UK) Ltd. The Digital and eTextbook ISBNs for Molecular ... Molecular Biology - Robert Franklin Weaver Find all the study resources for Molecular Biology by Robert Franklin Weaver. Molecular Biology 5th edition (9780073525327) Molecular Biology, 4/eby Robert Weaver, is designed for an introductory course in molecular biology. Molecular Biology 5/e focuses on the fundamental concepts ... BATTERY REPLACEMENT IN A FERRARI 458 - YouTube Tips for replacing 458 battery? Dec 19, 2022 — Disconnect the ground quick connect from the battery neg terminal. Lift up. Then loosen all battery clamps at the base & remove battery clamps. Changing FERRARI 458 Battery: step-by-step manuals How often to change the Battery on your FERRARI 458 . Recommended service and replacement schedules. every 70000 km / every 36 months. Replacing Battery 550 and 575 I can't find a thread about replacing the battery in a 550 or 575. It looks like the antifreeze container must come out. Do all the hoses need to be removed ... Antigravity Lithium Ion Battery - FERRARI 458 ... Dec 7, 2019 — You really need to be careful when jump starting a Ferrari as you can accidentally fry an ECU and then you're looking at massive repair bills! Mobile Car Battery Replacement, 24/7 Auto Battery Change ... Mobile Car Battery Replacement: Emergency Car and Motorbike Battery Delivery and Replacement Service Sydney. Cheap prices for automotive vehicle batteries ... How many Ferrari 458 Italia were made? Oct 17, 2015 — There isn't any official release from Ferrari, but here's my guess. There was a recall for a trunk latch problem that affected 3082 cars in ... Ferrari 458 Italia - Battery Buy BATTERY parts for the Ferrari 458 Italia. Order any in-stock part online and get it delivered in 2 days. 458 starting issue & electrical warning fault - Ferrari V8 Mar 31, 2017 — I would replace the battery if it's still on the original regardless - at the very least it will eliminate that as the problem, but six ... Medical Insurance Workbook Chapter 1 Answers.docx Medical Insurance Workbook Chapter 1 Answers Assignment 1.1 Review Questions 1.A.Hospitals, B.acute care hospitals, C.skilled nursing & long-term care ... Insurance Handbook For The Medical Office Flashcards Chapter -3 1-26 Learn with flashcards, games, and more — for free. 16IHMO Wk01 Ch01 worksheet Answerkey.pdf - Chapter 1 Answer routine inquiries related to account balances and insurance ... Insurance Billing Specialist Insurance Handbook for the Medical Office Workbook 9. Insurance Handbook for the Medical Office Chapter 3 ... Study with Quizlet and memorize flashcards containing terms like Insurance Policy, Guarantor, List 5 health insurance policy renewal provisions and more. Workbook for Insurance Handbook

for the Medical Office This user-friendly workbook features realistic, hands-on exercises to help you apply concepts and develop critical thinking skills. Study tools include ... Health insurance handbook : how to make it work (English) Health insurance handbook : how to make it work (English). Many countries that subscribe to the Millennium Development Goals (MDGs) have committed to ... Free Medical Flashcards about Insurance Handbook Study free Medical flashcards about Insurance Handbook created by FB to improve your grades. Matching game, word search puzzle, and hangman also available. Insurance Handbook The book begins with basic information on the various types of insurance, including auto, home, life, annuities and long-term care. A glossary section contains. Insurance Handbook for the Medical Office Oct 16, 2017 — Lesson 4.1 Documentation Basics Identify the most common documents founds in the medical record. List the advantages and disadvantages of an ... Chapter 9 Insurance Answer Key Medical Insurance: A Revenue Cycle Process Approach. Read Book Insurance Handbook For The Medical Office Answer Key Chapter 9 Health insurance in the United ...