

# PARTS DIAGRAM & PARTS LIST

## ENDURA 40 - 40 LBS THRUST - 12 VOLT - 36" SHAFT

This page provides Minn Kota® WEEE compliance disassembly instructions. For more information about where you should dispose of your waste equipment for recycling and recovery and/or your European Union member state requirements, please contact your dealer or distributor from which your product was purchased. Tools required, but not limited to: flat head screw driver, Phillips screw driver, socket set, pliers, wire cutters.

### ➤ Endura 40 Parts Diagram

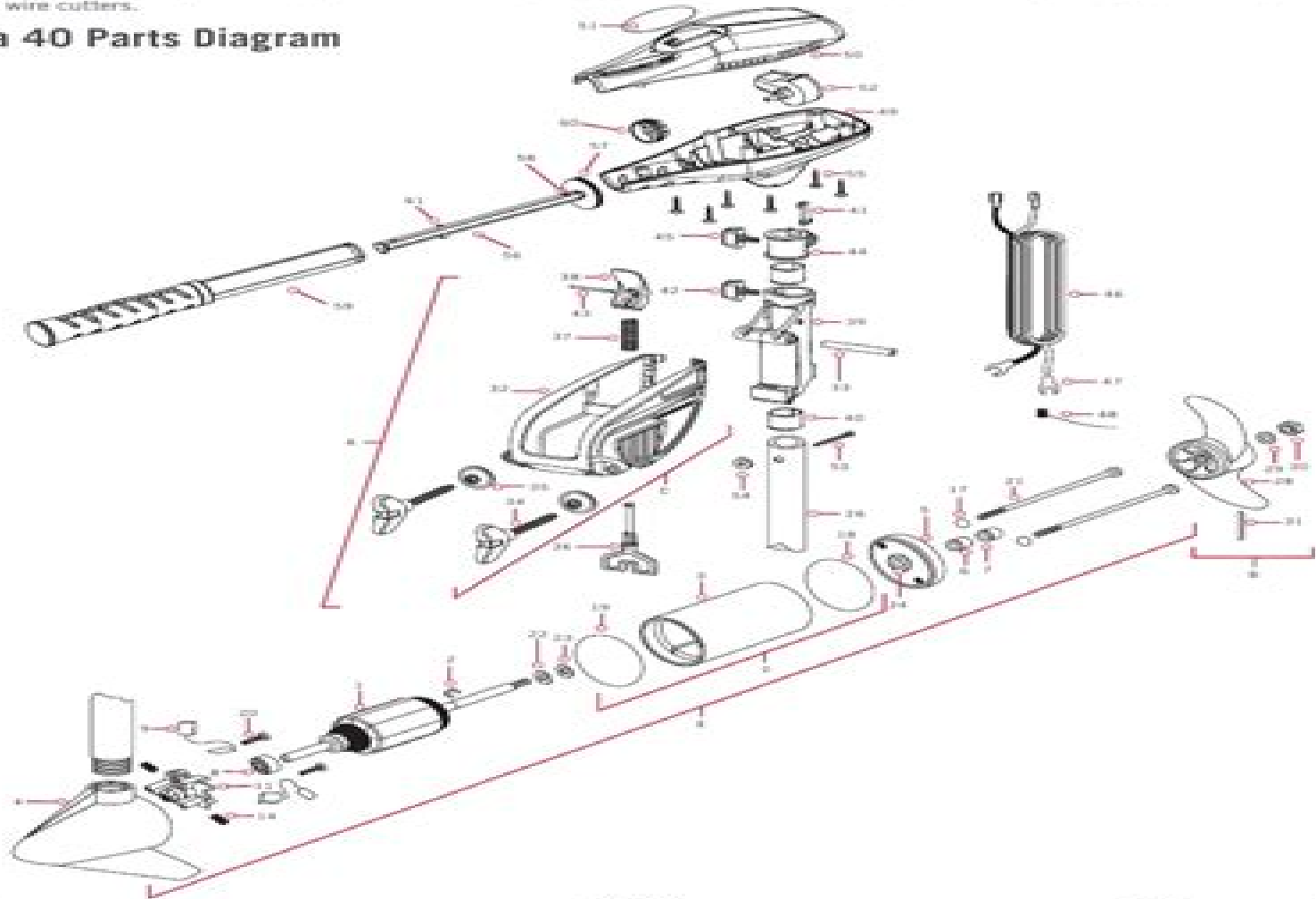

# Minn Kota Parts Manual

**C Cleary**



**Minn Kota Parts Manual:**

Immerse yourself in the artistry of words with Crafted by is expressive creation, **Minn Kota Parts Manual** . This ebook, presented in a PDF format ( Download in PDF: \*), is a masterpiece that goes beyond conventional storytelling. Indulge your senses in prose, poetry, and knowledge. Download now to let the beauty of literature and artistry envelop your mind in a unique and expressive way.

[https://staging.conocer.cide.edu/book/browse/index.jsp/little\\_love\\_notes.pdf](https://staging.conocer.cide.edu/book/browse/index.jsp/little_love_notes.pdf)

## **Table of Contents Minn Kota Parts Manual**

1. Understanding the eBook Minn Kota Parts Manual
  - The Rise of Digital Reading Minn Kota Parts Manual
  - Advantages of eBooks Over Traditional Books
2. Identifying Minn Kota Parts Manual
  - Exploring Different Genres
  - Considering Fiction vs. Non-Fiction
  - Determining Your Reading Goals
3. Choosing the Right eBook Platform
  - Popular eBook Platforms
  - Features to Look for in an Minn Kota Parts Manual
  - User-Friendly Interface
4. Exploring eBook Recommendations from Minn Kota Parts Manual
  - Personalized Recommendations
  - Minn Kota Parts Manual User Reviews and Ratings
  - Minn Kota Parts Manual and Bestseller Lists
5. Accessing Minn Kota Parts Manual Free and Paid eBooks
  - Minn Kota Parts Manual Public Domain eBooks
  - Minn Kota Parts Manual eBook Subscription Services
  - Minn Kota Parts Manual Budget-Friendly Options

6. Navigating Minn Kota Parts Manual eBook Formats
  - ePub, PDF, MOBI, and More
  - Minn Kota Parts Manual Compatibility with Devices
  - Minn Kota Parts Manual Enhanced eBook Features
7. Enhancing Your Reading Experience
  - Adjustable Fonts and Text Sizes of Minn Kota Parts Manual
  - Highlighting and Note-Taking Minn Kota Parts Manual
  - Interactive Elements Minn Kota Parts Manual
8. Staying Engaged with Minn Kota Parts Manual
  - Joining Online Reading Communities
  - Participating in Virtual Book Clubs
  - Following Authors and Publishers Minn Kota Parts Manual
9. Balancing eBooks and Physical Books Minn Kota Parts Manual
  - Benefits of a Digital Library
  - Creating a Diverse Reading Collection Minn Kota Parts Manual
10. Overcoming Reading Challenges
  - Dealing with Digital Eye Strain
  - Minimizing Distractions
  - Managing Screen Time
11. Cultivating a Reading Routine Minn Kota Parts Manual
  - Setting Reading Goals Minn Kota Parts Manual
  - Carving Out Dedicated Reading Time
12. Sourcing Reliable Information of Minn Kota Parts Manual
  - Fact-Checking eBook Content of Minn Kota Parts Manual
  - Distinguishing Credible Sources
13. Promoting Lifelong Learning
  - Utilizing eBooks for Skill Development
  - Exploring Educational eBooks
14. Embracing eBook Trends
  - Integration of Multimedia Elements

- Interactive and Gamified eBooks

## **Minn Kota Parts Manual Introduction**

Minn Kota Parts Manual Offers over 60,000 free eBooks, including many classics that are in the public domain. Open Library: Provides access to over 1 million free eBooks, including classic literature and contemporary works. Minn Kota Parts Manual Offers a vast collection of books, some of which are available for free as PDF downloads, particularly older books in the public domain. Minn Kota Parts Manual : This website hosts a vast collection of scientific articles, books, and textbooks. While it operates in a legal gray area due to copyright issues, its a popular resource for finding various publications. Internet Archive for Minn Kota Parts Manual : Has an extensive collection of digital content, including books, articles, videos, and more. It has a massive library of free downloadable books. Free-eBooks Minn Kota Parts Manual Offers a diverse range of free eBooks across various genres. Minn Kota Parts Manual Focuses mainly on educational books, textbooks, and business books. It offers free PDF downloads for educational purposes. Minn Kota Parts Manual Provides a large selection of free eBooks in different genres, which are available for download in various formats, including PDF. Finding specific Minn Kota Parts Manual, especially related to Minn Kota Parts Manual, might be challenging as theyre often artistic creations rather than practical blueprints. However, you can explore the following steps to search for or create your own Online Searches: Look for websites, forums, or blogs dedicated to Minn Kota Parts Manual, Sometimes enthusiasts share their designs or concepts in PDF format. Books and Magazines Some Minn Kota Parts Manual books or magazines might include. Look for these in online stores or libraries. Remember that while Minn Kota Parts Manual, sharing copyrighted material without permission is not legal. Always ensure youre either creating your own or obtaining them from legitimate sources that allow sharing and downloading. Library Check if your local library offers eBook lending services. Many libraries have digital catalogs where you can borrow Minn Kota Parts Manual eBooks for free, including popular titles. Online Retailers: Websites like Amazon, Google Books, or Apple Books often sell eBooks. Sometimes, authors or publishers offer promotions or free periods for certain books. Authors Website Occasionally, authors provide excerpts or short stories for free on their websites. While this might not be the Minn Kota Parts Manual full book , it can give you a taste of the authors writing style. Subscription Services Platforms like Kindle Unlimited or Scribd offer subscription-based access to a wide range of Minn Kota Parts Manual eBooks, including some popular titles.

## **FAQs About Minn Kota Parts Manual Books**

**What is a Minn Kota Parts Manual PDF?** A PDF (Portable Document Format) is a file format developed by Adobe that

preserves the layout and formatting of a document, regardless of the software, hardware, or operating system used to view or print it. **How do I create a Minn Kota Parts Manual PDF?** There are several ways to create a PDF: Use software like Adobe Acrobat, Microsoft Word, or Google Docs, which often have built-in PDF creation tools. Print to PDF: Many applications and operating systems have a "Print to PDF" option that allows you to save a document as a PDF file instead of printing it on paper. Online converters: There are various online tools that can convert different file types to PDF. **How do I edit a Minn Kota Parts Manual PDF?** Editing a PDF can be done with software like Adobe Acrobat, which allows direct editing of text, images, and other elements within the PDF. Some free tools, like PDFescape or Smallpdf, also offer basic editing capabilities. **How do I convert a Minn Kota Parts Manual PDF to another file format?** There are multiple ways to convert a PDF to another format: Use online converters like Smallpdf, Zamzar, or Adobe Acrobats export feature to convert PDFs to formats like Word, Excel, JPEG, etc. Software like Adobe Acrobat, Microsoft Word, or other PDF editors may have options to export or save PDFs in different formats. **How do I password-protect a Minn Kota Parts Manual PDF?** Most PDF editing software allows you to add password protection. In Adobe Acrobat, for instance, you can go to "File" -> "Properties" -> "Security" to set a password to restrict access or editing capabilities. Are there any free alternatives to Adobe Acrobat for working with PDFs? Yes, there are many free alternatives for working with PDFs, such as: LibreOffice: Offers PDF editing features. PDFsam: Allows splitting, merging, and editing PDFs. Foxit Reader: Provides basic PDF viewing and editing capabilities. How do I compress a PDF file? You can use online tools like Smallpdf, ILovePDF, or desktop software like Adobe Acrobat to compress PDF files without significant quality loss. Compression reduces the file size, making it easier to share and download. Can I fill out forms in a PDF file? Yes, most PDF viewers/editors like Adobe Acrobat, Preview (on Mac), or various online tools allow you to fill out forms in PDF files by selecting text fields and entering information. Are there any restrictions when working with PDFs? Some PDFs might have restrictions set by their creator, such as password protection, editing restrictions, or print restrictions. Breaking these restrictions might require specific software or tools, which may or may not be legal depending on the circumstances and local laws.

## **Find Minn Kota Parts Manual :**

**little love notes**

**little hen and the giant the**

**little by little quilts in miniature**

[literature express level 3 assessment](#)

**little monk**

[little joes big race](#)

[little bit of hope a](#)

[little of egyptian wisdom](#)

[literature works teachers guide theme 4 creative solutions](#)

**literature & language arts fourth course california standards**

[little giant of giggles](#)

[little hands create](#)

[little critters christmas storybook](#)

[little drummer girl](#)

[little giant encyclopedia of handwriting analysis](#)

### **Minn Kota Parts Manual :**

**aprilia rx 50 sx 50 user manual manualmachine com** - Jan 08 2023

web view and download aprilia rx 50 instruction manual online upload your files to the site you get 1 for each file you add

**aprilia sx 50 owner manual manualzz** - Mar 30 2022

web sx rx 50 les instructions de ce manuel ont été conçues comme un mode d emploi simple et clair ce manuel aborde également les opérations de petit entretien et les contrôles périodiques auxquels le véhicule doit être soumis chez

**aprilia rx 50 owner manual manualzz** - Nov 06 2022

web view online 6 pages or download pdf 368 kb aprilia rx 50 user manual rx 50 pdf manual download and more aprilia online manuals

[aprilia sx rx 50 2011 owner s manual pdf for free](#) - Feb 26 2022

web download and view your free pdf file of the aprilia sx rx 50 2011 owner manual on our comprehensive online database of motorcycle owners manuals

[aprilia rx 50 1996 manual pdf download manualslib](#) - Jul 14 2023

web summary of contents for aprilia rx 50 1996 page 2 n o r m and 85 n o m m and high performance synthetic oil for 2 stroke engines the use of fuels and lubricants different from those indicated causes severe functional inconveniences to the vehicle and the voiding of the

*aprilia rx50 sx50 2012 workshop service manual issuu* - Dec 07 2022

web jul 5 2020 mss sx rx 50 sx rx 50 this manual provides the main information to carry out regular maintenance operations on your vehicle this manual is intended to aprilia dealers and their

**aprilia rx 50 bedienungsanleitung pdf herunterladen** - Jun 01 2022



web ansicht und herunterladen aprilia rx 50 bedienungsanleitung online rx 50 monitore pdf anleitung herunterladen auch für rx 50 racing 2003 mx 50 2004

[aprilias rx 50 user manual 1996 manualmachine com](#) - Sep 04 2022

web a 2 catalytic silencer the catalytic version of the rx50 is fitted with a silencer with metal catalytic converter of the platinum rhodium bivalent type this device provides for the oxidation of the co carbon monoxide and of the hc unburned hydrocarbons contained in the exhaust gases changing them into carbon dioxide and

**aprilias rx 50 manual pdf download manualslib** - Aug 15 2023

web view and download aprilias rx 50 manual online rx 50 motorcycle pdf manual download also for sx 50

**aprilias rx 50 manuals manualsbrain com** - Aug 03 2022

web rx 50 aprilias rx 50 user manuals user manual nederlands user manual nederlands brochure english user manual english user manual english user manual english

[aprilias rx 50 sx 50 manual manualzz](#) - Oct 05 2022

web manual aprilias rx 50 sx 50 manual

**aprilias rx 50 2007 manual pdf download manualslib** - Jun 13 2023

web view and download aprilias rx 50 2007 manual online rx 50 2007 motorcycle pdf manual download also for sx 50 2007 sx 50 rx 50

[aprilias rx 50 user manual manualmachine com](#) - Mar 10 2023

web rx 50 sx 50 ed 03 2009 the instructions in this booklet have been compiled primarily to offer a simple and clear guide to using the vehicle it also describes routine maintenance procedures and regular checks that should be carried out on the vehicle at an aprilias dealer or authorised workshop

**aprilias rx 50 sx 50 user manual manualmachine com** - Jul 02 2022

web les instructions de ce manuel ont été conçues comme un mode d emploi simple et clair ce manuel aborde également les opérations de petit entretien et les contrôles périodiques auxquels le véhicule doit être soumis chez les concessionnaires ou garages agréés aprilias

**aprilias sx 50 owner manual manualzz** - Jan 28 2022

web rx 50 sx 50 ed 03 2009 the instructions in this booklet have been compiled primarily to offer a simple and clear guide to using the vehicle it also describes routine maintenance procedures and regular checks that should be carried out on the vehicle at an aprilias dealer or authorised workshop

*bedienungsanleitung aprilias rx 50 laden sie ihre aprilias rx 50* - Dec 27 2021

web diebedienungsanleitung hilfe zum download von aprilias rx 50 aprilias rx 50 laden sie die komplette bedienungsanleitung

herunter 899 ko sie können sich auch noch diese handbücher die sich auf ihr produkt beziehen herunterladen aprilia rx 50 2001 1306 ko aprilia rx 50 2002 1608 ko aprilia rx 50 2003 3246 ko aprilia rx 50

**aprilias rx 50 handbücher manualslib** - Apr 30 2022

web anleitungen und benutzerhandbücher für aprilia rx 50 wir haben 2 aprilia rx 50 anleitungen zum kostenlosen pdf download zur verfügung bedienungsanleitung aprilia rx 50 bedienungsanleitung 139 seiten

**aprilias rx 50 annexe 20 manual pdf download manualslib** - May 12 2023

web view and download aprilia rx 50 annexe 20 manual online rx 50 annexe 20 motorcycle pdf manual download also for sx 50 annexe 639 sx 50 rx 50

*aprilias rx 50 user manual page 1 of 95 manualsbrain com* - Feb 09 2023

web aprilia would like to thank you for choosing one of its products we have compiled this booklet to provide a comprehensive overview of your vehicle s quality features

*aprilias rx 50 2003 manual pdf download manualslib* - Apr 11 2023

web view and download aprilia rx 50 2003 manual online rx 50 2003 motorcycle pdf manual download also for rx 50

**linguistique et didactique de l allemand a voluti wrbb neu** - Dec 07 2022

web 4 linguistique et didactique de l allemand a voluti 2020 12 13 fondamentale en linguistique la phrase carrefour linguistique et didactique editions l harmattan

**pdf de la didactique de l allemand à une didactique du** - Nov 06 2022

web de la didactique de l allemand à une didactique du plurilinguisme la recherche action comme ai de au changement volume 1 11 l institutio n pour e n marque r le lien fort

[fiches de vocabulaire allemand pdf fichesvocabulary com](#) - Apr 30 2022

web chaque fiche de vocabulaire allemand par thème que vous trouverez sur cette page comporte les mots essentiels à apprendre et mémoriser elles vous seront utile pour le

**linguistique et didactique de l allemand a voluti pdf api** - Jun 01 2022

web voluti 1 linguistique et didactique de l allemand a voluti recognizing the habit ways to acquire this books linguistique et didactique de l allemand a voluti is

[linguistique et didactique de l allemand a voluti 2022](#) - Apr 11 2023

web analyse linguistique et didactique de l intervention du thai l1 et de l anglais l2 dans l enseignement l apprentissage du francais l3 en thailande de la langue à la culture

*linguistique et didactique de l allemand a voluti pdf uniport edu* - Dec 27 2021

web aug 19 2023 this linguistique et didactique de l allemand a voluti as one of the most working sellers here will entirely

be in the midst of the best options to review

**pdf linguistique et didactique de l allemand a voluti** - Jul 14 2023

web linguistique et didactique de l allemand a voluti didactique du franais apr 12 2020 cet ouvrage presente une synthse des principales questions lies l enseignement de la

**linguistique et didactique allemand École normale** - Feb 26 2022

web sep 28 2020 lucie lebrun publié le 28 09 2020 cet article propose des pistes pour l enseignement de la grammaire allemande en collège lycée la première partie revient

**linguistique et didactique allemand École normale** - Jun 13 2023

web sep 28 2020 les parties suivantes sont consacrées à des propositions tirées de différents travaux de recherche en didactique qui ont pour enjeu de mobiliser davantage les

*linguistique et didactique de l allemand a voluti pdf* - Aug 03 2022

web jan 12 2023 linguistique et didactique de l allemand jacques athias 1995 01 01 lire une grammaire moderne élaborée de l allemand n est pas toujours aisé car les

**linguistique et didactique de l allemand a voluti eugene l** - Mar 10 2023

web as capably as perception of this linguistique et didactique de l allemand a voluti can be taken as with ease as picked to act bilingual and multicultural education stan

**linguistique et didactique de l allemand a voluti copy** - Sep 23 2021

web jun 27 2023 linguistique et didactique de l allemand a voluti 1 9 downloaded from uniport edu ng on june 27 2023 by guest linguistique et didactique de l allemand

**linguistique et didactique de l allemand a voluti 2023** - Aug 15 2023

web l appuyant sur la connaissance de l anglais ou réciproquement d aborder plus facilement l anglais connaissant l allemand ou de mieux comprendre l évolution de ces deux

linguistique et didactique de l allemand a voluti copy - Nov 25 2021

web jul 27 2023 linguistique et didactique de l allemand a voluti 2 9 downloaded from uniport edu ng on july 27 2023 by guest et orientale à la lumière des actions en faveur

**linguistique et didactique de l allemand a voluti pdf** - Oct 25 2021

web jun 25 2023 linguistique et didactique de l allemand a voluti 3 14 downloaded from uniport edu ng on june 25 2023 by guest suisse romande entre 1790 et 1940 et

**linguistique et didactique de l allemand à volution des** - Jul 02 2022

web enseignement hep vaud didactique de l allemand didactiques fr linguistique et didactique de l allemand linguistique et

didactique traduction anglaise linguee

**linguistique et didactique de l allemand a voluti** - Feb 09 2023

web boudreau roselyne lampron linguistique et didactique de l allemand aug 10 2022 lire une grammaire moderne élaborée de l allemand n est pas toujours aisé car

**linguistique et didactique de l allemand a voluti pdf** - Jan 28 2022

web aug 2 2023 linguistique et didactique de l allemand a voluti recognizing the way ways to get this books linguistique et didactique de l allemand a voluti is additionally

**linguistique et didactique de l allemand a voluti copy ftp** - Jan 08 2023

web linguistique interactionnelle grammaire de l oral et didactique du français le discours rapporté analyse linguistique et didactique de l intervention du thai

**linguistique et didactique de l allemand à évolution des thèses** - Sep 04 2022

web cette étude des relations entre la linguistique et la didactique développe deux grands axes l évolution de la recherche linguistique replacée au sein des concepts de la

**apprenez l allemand leçon 93 aéroport et départ** - Mar 30 2022

web aéroport et départ vocabulaire allemand aéroport der flughafen vol der flug billet der flugschein numéro de vol die flugnummer porte d embarquement der

*linguistique et didactique de l allemand a voluti pdf* - May 12 2023

web aug 8 2023 exploratoire relative à l échec de l implémentation de la langue et de la culture allemandes la germanisation au cameroun pendant la période coloniale de 1884 à

**linguistique et didactique de l allemand à évolution des** - Oct 05 2022

web jun 9 2023 cette étude des relations entre la linguistique et la didactique développe deux grands axes l évolution de la recherche linguistique replacée au sein des

**İzmir buca meşkure Şamlı ortaokulu** - Jun 05 2023

web 0 232 487 50 59 e posta göndermek için tıklayınız adres menderes mahallesi 118 3 sokak no 5 buca İzmir t c millî eğitim bakanlığı İzmir buca meşkure Şamlı ortaokulu

**school me muth mara uniport edu ng** - Oct 29 2022

web jul 16 2023 school me muth mara 2 10 downloaded from uniport edu ng on july 16 2023 by guest pages of the 1977 curriculum jk university of california union catalog of monographs cataloged by the nine campuses from 1963 through 1967 authors titles university of california system institute of library research 1972 assembly united

school me muth mara domainlookup - Sep 27 2022

web mar 25 2023 school me muth mara right here we have countless ebook school me muth mara and collections to check out we additionally have enough money variant types and moreover type of the books to browse the gratifying book fiction history novel scientific research as well as various supplementary sorts of books are readily

[school me muth mara waptac org](#) - Sep 08 2023

web school me muth mara the new york times index 1924 adolescence and poverty peter b edelman 1991 the current situation for poor adolescents in the united states is reviewed in this collection of essays and some strategies and insights for policymakers are presented the essays of this volume cover the basic

**school me muth mara kelliemay com** - Mar 22 2022

web dec 21 2022 school me muth mara 2 8 downloaded from kelliemay com on december 21 2022 by guest baltimore city directory 1926 inquiry based lessons in u s history jana kirchner 2021 09 03 inquiry based lessons in u s history decoding the past provides primary source lessons that focus on teaching u s history through inquiry to middle

[school me muth mara controlplane themintgaming com](#) - Jul 26 2022

web school me muth mara a to zoo subject access to children s picture books 10th edition saint francis school library journal journalism and the school paper

**school me muth mara uniport edu ng** - Feb 18 2022

web school me muth mara 2 6 downloaded from uniport edu ng on june 10 2023 by guest school library journal 2009 07 general catalogue washington catholic university of america d c 1939 a to zoo supplement to the ninth edition subject access to children s picture books 9th edition

**school me muth mara wrbb neu edu** - Jun 24 2022

web 2 school me muth mara 2021 09 26 considered with criticism and major reviews of the film as well as henry louis gates s three interviews with its director steve mcqueen a chronology and selected bibliography journalism and the school paper artisan 1001 children s books you must read before you grow up is the perfect

**download solutions school me muth mara** - Dec 31 2022

web school me muth mara good and cheap dec 07 2020 a perfect and irresistible idea a cookbook filled with delicious healthful recipes created for everyone on a tight budget while studying food policy as a master s candidate at nyu leanne brown asked a

[school me muth mara uniport edu ng](#) - May 04 2023

web may 2 2023 school me muth mara 2 6 downloaded from uniport edu ng on may 2 2023 by guest 1001 children s books you must read before you grow up julia eccleshare 2009 10 27 this is the best and most authoritative guide to classic and contemporary children s literature today it is the latest in the best selling

*haftalık ders programı metalurji ve malzeme mühendisliği - Feb 01 2023*

web haftalık ders programı marmara Üniversitesi köklü geçmiş güçlü gelecek

[school me muth mara wrbb neu edu](#) - Oct 09 2023

web kindly say the school me muth mara is universally compatible with any devices to read school me muth mara 2019 07 10 best bradley the dean of lismore s book penguin make sure you re studying with the most up to date prep materials look for the newest edition of this title the princeton review sat prep 2023 isbn 9780593450598 on

**school me muth mara uniport edu ng** - Apr 22 2022

web may 11 2023 school me muth mara 2 6 downloaded from uniport edu ng on may 11 2023 by guest retelling of aladdin follows the story of the classic animated film see how disney s artists interpreted the story through different styles and mediums and follow aladdin on his adventures in agrabah

[school me muth mara uniport edu ng](#) - Jul 06 2023

web apr 17 2023 merely said the school me muth mara is universally compatible once any devices to read my survival a girl on schindler s list joshua m greene 2019 12 26 the astonishing true story of a girl who survived the holocaust thanks to oskar schindler of schindler s list fame rena finder was only

*marmara eğitim kurumları mek k12 tr* - Apr 03 2023

web İnsan haklarına saygılı ve çevreye duyarlı kültürel ve kişisel farklılıklara hoşgörülü dünya çapında bilgiye ulaşabilecek becerilerle donatılmış barış ve birlik anlayışına sahip öğrenciler eğitmek ve yetiştirmek

**school me muth mara life io** - Nov 29 2022

web 2 school me muth mara 2023 09 21 shaniya karlee the granite cutters journal university of georgia press collection of the monthly climatological reports of the united states by state or region with monthly and annual national summaries a dictionary sindhi and english summer inst of linguistics

**school me muth mara iriss ac uk** - Aug 07 2023

web 2 school me muth mara 2020 10 06 miles davis new research on miles davis his cir cle vs

**ders programları endüstri mühendisliği marmara Üniversitesi** - Mar 02 2023

web ders programları marmara Üniversitesi köklü geçmiş güçlü gelecek

**school me muth mara uniport edu ng** - May 24 2022

web school me muth mara 1 7 downloaded from uniport edu ng on april 25 2023 by guest school me muth mara when people should go to the books stores search instigation by shop shelf by shelf it is essentially problematic this is why we allow the ebook compilations in this website it will definitely ease you to

**school me muth mara 2 pdf yearbook ladieseuropentour com** - Aug 27 2022

web school me muth mara 2 pdf upload mita b paterson 2 23 downloaded from yearbook ladieseuropentour com on october 8 2023 by mita b paterson learned in the main to co exist harmoniously creating a society comprising of a variety of distinct populations this is the first book to provide a seamless account of the millennium old