

FEATURES MANUAL START - 30-35
25 ILLUSTRATED

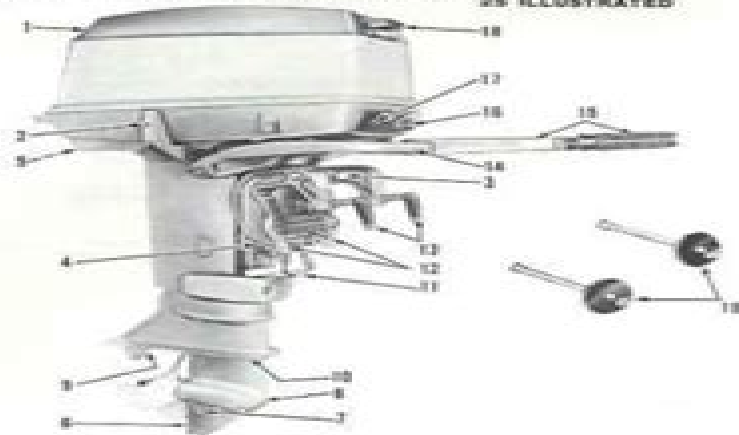

STARBOARD VIEW

- | | |
|---|--|
| 1. Motor Cover | 13. Clamp Screws |
| 2. Shift Lever | 14. Steering Bracket
(Remote Control) |
| 3. Release Lock Lever | 15. Steering Handle and
Twin Grip Throttle -
Manual Start Only |
| 4. Angle Adjustment Rod
Release | 16. Stop Button
(Manual Start) |
| 5. Water Pump Indicator | 17. Choke Knob
(Manual Start Only) |
| 6. Sump | 18. Starter Handle
(Manual Start Only) |
| 7. Oil Drain/Fill Plug | 19. Motor Mounting Hardware |
| 8. Water Intake
(Port and Starboard) | |
| 9. Water Intake | |
| 10. Oil Level Plug | |
| 11. Shallow Water Drive Bracket | |
| 12. Stern Brackets | |

ENGLEIGH ELECTRIC

FEATURES MANUAL START - 25



PORT VIEW

- | | |
|---|------------------------------|
| 20. Fuel Connector | 39. Locking Lever - Cover |
| 21. Tilt Pin (Pin Steering
(Remote Control)) | 40. Motor Rest |
| 22. Motor and Serial
Number | 41. Tilt Grip |
| 23. Angle Adjusting Rod | 42. Anti-Corrosion Plate |
| 24. Propeller | 43. AC Connector |
| 25. Underwater Exhaust
and Water Outlet | 44. Start/Choke Switch & Key |
| 26. Water Pump
(Under Housing) | 45. Fuel Tank |
| 27. Exhaust Rotor | 46. Priming Bulb |
| 28. Idle Speed Adjusting
Screw | 47. Filter Cap |
| | 48. Handle |
| | 49. Fuel Line |
| | 50. Fuel Gauge |
| | 51. Drain Screw |

ENGLEIGH ELECTRIC

FEATURES MANUAL START - 35

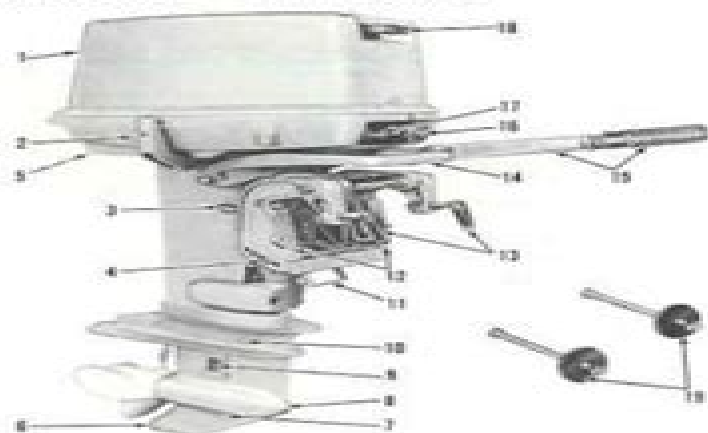

STARBOARD VIEW

- | | |
|---|--|
| 1. Motor Cover | 13. Clamp Screws |
| 2. Shift Lever | 14. Steering Bracket
(Remote Control) |
| 3. Tilt/Run Lever | 15. Steering Handle and
Twin Grip Throttle -
Manual Start Only |
| 4. Angle Adjustment Rod
Release | 16. Stop Button
(Manual Start) |
| 5. Water Pump Indicator | 17. Choke Knob
(Manual Start Only) |
| 6. Sump | 18. Starter Handle
(Manual Start Only) |
| 7. Oil Drain/Fill Plug | 19. Motor Mounting Hardware |
| 8. Water Intake
(Port and Starboard) | |
| 9. Water Intake | |
| 10. Oil Level Plug | |
| 11. Shallow Water Drive Bracket | |
| 12. Stern Brackets | |

ENGLEIGH ELECTRIC

ELECTRIC START - 20

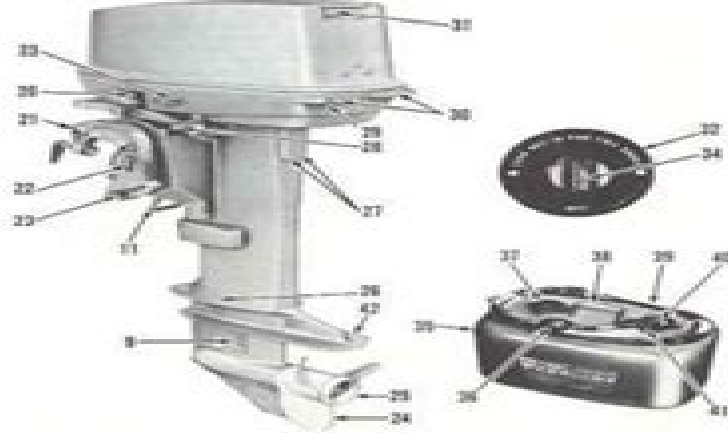

PORT VIEW

- | | |
|---|--|
| 20. Fuel Connector | 39. Locking Lever - Electric |
| 21. Tilt Pin (Pin Steering
(Remote Control)) | 40. Motor Rest |
| 22. Motor and Serial
Number | 41. Tilt Grip |
| 23. Angle Adjusting Rod | 42. Anti-Corrosion Plate
(Cable Assembly) |
| 24. Propeller | 43. AC Connector |
| 25. Underwater Exhaust
and Water Outlet | 44. Start/Choke Switch & Key |
| 26. Water Pump
(Under Housing) | 45. Fuel Tank |
| 27. Exhaust Rotor | 46. Priming Bulb |
| 28. Idle Speed Adjusting
Screw | 47. Filter Cap |
| 29. Locking Lever - Cover | 48. Handle |
| 30. Motor Rest | 49. Fuel Line |
| | 50. Fuel Gauge |
| | 51. Drain Screw |

ENGLEIGH ELECTRIC

Manual For A Johnson 30hp Outboard

RS Peters



Manual For A Johnson 30hp Outboard:

Unveiling the Magic of Words: A Report on "**Manual For A Johnson 30hp Outboard**"

In some sort of defined by information and interconnectivity, the enchanting power of words has acquired unparalleled significance. Their capability to kindle emotions, provoke contemplation, and ignite transformative change is actually awe-inspiring. Enter the realm of "**Manual For A Johnson 30hp Outboard**," a mesmerizing literary masterpiece penned by a distinguished author, guiding readers on a profound journey to unravel the secrets and potential hidden within every word. In this critique, we shall delve into the book's central themes, examine its distinctive writing style, and assess its profound affect on the souls of its readers.

<https://staging.conocer.cide.edu/book/uploaded-files/fetch.php/gotcha%20how%20the%20media%20distorts%20the%20news.pdf>

Table of Contents Manual For A Johnson 30hp Outboard

1. Understanding the eBook Manual For A Johnson 30hp Outboard
 - The Rise of Digital Reading Manual For A Johnson 30hp Outboard
 - Advantages of eBooks Over Traditional Books
2. Identifying Manual For A Johnson 30hp Outboard
 - Exploring Different Genres
 - Considering Fiction vs. Non-Fiction
 - Determining Your Reading Goals
3. Choosing the Right eBook Platform
 - Popular eBook Platforms
 - Features to Look for in an Manual For A Johnson 30hp Outboard
 - User-Friendly Interface
4. Exploring eBook Recommendations from Manual For A Johnson 30hp Outboard
 - Personalized Recommendations
 - Manual For A Johnson 30hp Outboard User Reviews and Ratings

- Manual For A Johnson 30hp Outboard and Bestseller Lists
- 5. Accessing Manual For A Johnson 30hp Outboard Free and Paid eBooks
 - Manual For A Johnson 30hp Outboard Public Domain eBooks
 - Manual For A Johnson 30hp Outboard eBook Subscription Services
 - Manual For A Johnson 30hp Outboard Budget-Friendly Options
- 6. Navigating Manual For A Johnson 30hp Outboard eBook Formats
 - ePub, PDF, MOBI, and More
 - Manual For A Johnson 30hp Outboard Compatibility with Devices
 - Manual For A Johnson 30hp Outboard Enhanced eBook Features
- 7. Enhancing Your Reading Experience
 - Adjustable Fonts and Text Sizes of Manual For A Johnson 30hp Outboard
 - Highlighting and Note-Taking Manual For A Johnson 30hp Outboard
 - Interactive Elements Manual For A Johnson 30hp Outboard
- 8. Staying Engaged with Manual For A Johnson 30hp Outboard
 - Joining Online Reading Communities
 - Participating in Virtual Book Clubs
 - Following Authors and Publishers Manual For A Johnson 30hp Outboard
- 9. Balancing eBooks and Physical Books Manual For A Johnson 30hp Outboard
 - Benefits of a Digital Library
 - Creating a Diverse Reading Collection Manual For A Johnson 30hp Outboard
- 10. Overcoming Reading Challenges
 - Dealing with Digital Eye Strain
 - Minimizing Distractions
 - Managing Screen Time
- 11. Cultivating a Reading Routine Manual For A Johnson 30hp Outboard
 - Setting Reading Goals Manual For A Johnson 30hp Outboard
 - Carving Out Dedicated Reading Time
- 12. Sourcing Reliable Information of Manual For A Johnson 30hp Outboard
 - Fact-Checking eBook Content of Manual For A Johnson 30hp Outboard
 - Distinguishing Credible Sources

13. Promoting Lifelong Learning
 - Utilizing eBooks for Skill Development
 - Exploring Educational eBooks
14. Embracing eBook Trends
 - Integration of Multimedia Elements
 - Interactive and Gamified eBooks

Manual For A Johnson 30hp Outboard Introduction

In today's digital age, the availability of Manual For A Johnson 30hp Outboard books and manuals for download has revolutionized the way we access information. Gone are the days of physically flipping through pages and carrying heavy textbooks or manuals. With just a few clicks, we can now access a wealth of knowledge from the comfort of our own homes or on the go. This article will explore the advantages of Manual For A Johnson 30hp Outboard books and manuals for download, along with some popular platforms that offer these resources. One of the significant advantages of Manual For A Johnson 30hp Outboard books and manuals for download is the cost-saving aspect. Traditional books and manuals can be costly, especially if you need to purchase several of them for educational or professional purposes. By accessing Manual For A Johnson 30hp Outboard versions, you eliminate the need to spend money on physical copies. This not only saves you money but also reduces the environmental impact associated with book production and transportation. Furthermore, Manual For A Johnson 30hp Outboard books and manuals for download are incredibly convenient. With just a computer or smartphone and an internet connection, you can access a vast library of resources on any subject imaginable. Whether you're a student looking for textbooks, a professional seeking industry-specific manuals, or someone interested in self-improvement, these digital resources provide an efficient and accessible means of acquiring knowledge. Moreover, PDF books and manuals offer a range of benefits compared to other digital formats. PDF files are designed to retain their formatting regardless of the device used to open them. This ensures that the content appears exactly as intended by the author, with no loss of formatting or missing graphics. Additionally, PDF files can be easily annotated, bookmarked, and searched for specific terms, making them highly practical for studying or referencing. When it comes to accessing Manual For A Johnson 30hp Outboard books and manuals, several platforms offer an extensive collection of resources. One such platform is Project Gutenberg, a nonprofit organization that provides over 60,000 free eBooks. These books are primarily in the public domain, meaning they can be freely distributed and downloaded. Project Gutenberg offers a wide range of classic literature, making it an excellent resource for literature enthusiasts. Another popular platform for Manual For A Johnson 30hp Outboard books and manuals is Open Library. Open Library is an initiative of the Internet Archive, a non-profit organization dedicated to digitizing cultural

artifacts and making them accessible to the public. Open Library hosts millions of books, including both public domain works and contemporary titles. It also allows users to borrow digital copies of certain books for a limited period, similar to a library lending system. Additionally, many universities and educational institutions have their own digital libraries that provide free access to PDF books and manuals. These libraries often offer academic texts, research papers, and technical manuals, making them invaluable resources for students and researchers. Some notable examples include MIT OpenCourseWare, which offers free access to course materials from the Massachusetts Institute of Technology, and the Digital Public Library of America, which provides a vast collection of digitized books and historical documents. In conclusion, Manual For A Johnson 30hp Outboard books and manuals for download have transformed the way we access information. They provide a cost-effective and convenient means of acquiring knowledge, offering the ability to access a vast library of resources at our fingertips. With platforms like Project Gutenberg, Open Library, and various digital libraries offered by educational institutions, we have access to an ever-expanding collection of books and manuals. Whether for educational, professional, or personal purposes, these digital resources serve as valuable tools for continuous learning and self-improvement. So why not take advantage of the vast world of Manual For A Johnson 30hp Outboard books and manuals for download and embark on your journey of knowledge?

FAQs About Manual For A Johnson 30hp Outboard Books

How do I know which eBook platform is the best for me? Finding the best eBook platform depends on your reading preferences and device compatibility. Research different platforms, read user reviews, and explore their features before making a choice. Are free eBooks of good quality? Yes, many reputable platforms offer high-quality free eBooks, including classics and public domain works. However, make sure to verify the source to ensure the eBook credibility. Can I read eBooks without an eReader? Absolutely! Most eBook platforms offer webbased readers or mobile apps that allow you to read eBooks on your computer, tablet, or smartphone. How do I avoid digital eye strain while reading eBooks? To prevent digital eye strain, take regular breaks, adjust the font size and background color, and ensure proper lighting while reading eBooks. What the advantage of interactive eBooks? Interactive eBooks incorporate multimedia elements, quizzes, and activities, enhancing the reader engagement and providing a more immersive learning experience. Manual For A Johnson 30hp Outboard is one of the best book in our library for free trial. We provide copy of Manual For A Johnson 30hp Outboard in digital format, so the resources that you find are reliable. There are also many Ebooks of related with Manual For A Johnson 30hp Outboard. Where to download Manual For A Johnson 30hp Outboard online for free? Are you looking for Manual For A Johnson 30hp Outboard PDF? This is definitely going to save you time and cash in something you should think about. If you

trying to find then search around for online. Without a doubt there are numerous these available and many of them have the freedom. However without doubt you receive whatever you purchase. An alternate way to get ideas is always to check another Manual For A Johnson 30hp Outboard. This method for see exactly what may be included and adopt these ideas to your book. This site will almost certainly help you save time and effort, money and stress. If you are looking for free books then you really should consider finding to assist you try this. Several of Manual For A Johnson 30hp Outboard are for sale to free while some are payable. If you arent sure if the books you would like to download works with for usage along with your computer, it is possible to download free trials. The free guides make it easy for someone to free access online library for download books to your device. You can get free download on free trial for lots of books categories. Our library is the biggest of these that have literally hundreds of thousands of different products categories represented. You will also see that there are specific sites catered to different product types or categories, brands or niches related with Manual For A Johnson 30hp Outboard. So depending on what exactly you are searching, you will be able to choose e books to suit your own need. Need to access completely for Campbell Biology Seventh Edition book? Access Ebook without any digging. And by having access to our ebook online or by storing it on your computer, you have convenient answers with Manual For A Johnson 30hp Outboard To get started finding Manual For A Johnson 30hp Outboard, you are right to find our website which has a comprehensive collection of books online. Our library is the biggest of these that have literally hundreds of thousands of different products represented. You will also see that there are specific sites catered to different categories or niches related with Manual For A Johnson 30hp Outboard So depending on what exactly you are searching, you will be able to choose ebook to suit your own need. Thank you for reading Manual For A Johnson 30hp Outboard. Maybe you have knowledge that, people have search numerous times for their favorite readings like this Manual For A Johnson 30hp Outboard, but end up in harmful downloads. Rather than reading a good book with a cup of coffee in the afternoon, instead they juggled with some harmful bugs inside their laptop. Manual For A Johnson 30hp Outboard is available in our book collection an online access to it is set as public so you can download it instantly. Our digital library spans in multiple locations, allowing you to get the most less latency time to download any of our books like this one. Merely said, Manual For A Johnson 30hp Outboard is universally compatible with any devices to read.

Find Manual For A Johnson 30hp Outboard :

gotcha how the media distorts the news

goupil gallery photogravures great moder

good the bad and the cuddly bachelors and babies

good style

gourmet on the go; delectable chinese recipes adapted for western usage by...

gorillas gentle giants of the forest step into reading

good housekeeping cooking for vegetarian children

goofproof skits for youth ministry

goodnight my friend aleph

goodnight children everywhere

gore on stage

good night chet a biography of chet huntley

~~good night henry~~

goodbye is forever

good-bye doesnt mean forever

Manual For A Johnson 30hp Outboard :

2005-2007 Jeep Liberty Vehicle Wiring Chart and Diagram Listed below is the vehicle specific wiring diagram for your car alarm, remote starter or keyless entry installation into your 2005-2007 Jeep Liberty . This ... Need wiring diagram for 2006 Jeep Liberty 3.7L automatic Jun 20, 2022 — Need wiring diagram for 2006 Jeep Liberty 3.7L automatic ... I find the starter relay a convenient place to trouble shoot wiring, Check fuses then ... I need to get a wire diagram for the ignition switch....what Aug 16, 2023 — I need to get a wire diagram for the ignition switch....what colors are what and how many I should have in the connector Jeep Liberty. 2006 Jeep Liberty Alarm Wiring - the12volt.com Oct 14, 2006 — This is a 1-wire system with resistors. The keyless entry is built in to the ignition key and works even while the vehicle is running. I need a wiring diagram for a 2006 Jeep Liberty. Have one ... Dec 13, 2007 — I need a wiring diagram for a 2006 Jeep Liberty. Have one? 3.7 L. - Answered by a verified Auto Mechanic. 2006 Jeep Liberty Wiring Diagram 2006 Jeep Liberty Wiring Diagram . 2006 Jeep Liberty Wiring Diagram . A71e0 Kia Radio Wiring Diagrams. E340 ford F 1 Wiring Diagram. Ignition switch wire colors Apr 2, 2019 — Im unsure though of which wires to check for continuity between. I think this is the correct wiring diagram. I found it in my Haynes repair ... Push button start wiring | Jeep KJ and KK Liberty Forum Nov 3, 2012 — Anyone knows what wires to use to install a push button start or have a wire schematic for an 06 libby. ... ignition switch to START by using a ... Wiring Diagrams | Jeep KJ and KK Liberty Forum Apr 26, 2017 — Anybody know where I could find a PDF of wiring diagrams for an '05 Jeep Liberty Renegade? KINGSTON Class MCDV About the Model The fleet of 12 MCDV's (6 per coast) are crewed primarily by reservists. This class of ship provides the navy with a dedicated coastal defence capability, and ... HMCS Kingston The original. The Kingston-class vessels were built as part of the Canadian Maritime Coastal Defence Vessel

Project. There are twelve ships in this class ... MM-700 HMCS Kingston - Coastal Defence Vessel The first ship to be constructed at Halifax in 32 years, Kingston was commissioned into the Canadian Forces at Kingston, Ontario on 21 September 1996 and ... Boats and Ships Free Paper Models Delphin Boat - Choose "Downloads" for the free model boat. Digital Navy - Great paper model ships: Lightship Ambrose, H.M.S. Dreadnought, Admirable Class ... Maritime Coastal Defence Vessels Sep 24, 2021 — HMCS Summerside Kingston-class coastal defense vessel. ... Since you came this far, the RCN offers a free paper model for download, should you be ... DEPARTMENT OF NATIONAL DEFENCE. The Kingston ... DEPARTMENT OF NATIONAL DEFENCE The Kingston Class Vessel Dossier LIST OF EFFECTIVE PAGES Insert latest changed pages, dispose of superseded pages in ... Barcos de guerra HMCS Kingston (MM 700) Coastal Defence Vessel Free Ship Paper Model Download. HMCS Kingston (MM 700) Coastal Defence Vessel Free Ship Paper Model Download. RIMPAC Aug 8, 2022 — HMCS Summerside Kingston-class coastal defense vessel. While not ... Since you came this far, the RCN offers a free paper model for download, ... HMCS Kingston, Hull (1:200, RC) Parts in "Strong & Flexible" material to complete the model of the Canadian military vessel "HMCS Kingston", a coastal defence vessel, in 1:200 scale:. 1995 Lexus ES 300 ES300 Owners manual Book #119 Find many great new & used options and get the best deals for 1995 Lexus ES 300 ES300 Owners manual Book #119 at the best online prices at eBay! 1995 Lexus ES 300 Owners Manual Book Find many great new & used options and get the best deals for 1995 Lexus ES 300 Owners Manual Book at the best online prices at eBay! Free shipping for many ... 1995 Lexus Es300 Owners Manual Book Guide P/N:01999 ... 1995 Lexus Es300 Owners Manual Book Guide P/N:01999-33444 OEM Used Auto Parts. SKU:229233. In stock. We have 1 in stock. Regular price \$ 17.15 Sale. 1995 Lexus ES 300 Owners Manual Original Owner's Manuals explain the operation and care of your vehicle. With step-by-step instructions, clear pictures, fluid capacities and specifications, ... 1995 LEXUS ES-300 ES300 Service Repair Manual Aug 16, 2019 — Read 1995 LEXUS ES-300 ES300 Service Repair Manual by 1636911 on Issuu and browse thousands of other publications on our platform. 1995 Lexus ES300 Owner's Manual Original factory 1995 Lexus ES300 Owner's Manual by DIY Repair Manuals. Best selection and lowest prices on owners manual, service repair manuals, ... 1995 LEXUS ES300 ES 300 Service Shop Repair Manual ... This manual will save you money in repairs/service. A must have if you own one of these vehicles. This manual is published by LEXUS, and are the same manuals ... Lexus Es300 Service Manual: Books 1995 LEXUS ES300 ES 300 Service Shop Repair Manual Set W Wiring Diagram ... Repair Manual (Chilton's Total Car Care Repair Manuals). by Chilton. Part of: ... 1995 Lexus ES300 Manuals 1995 Lexus ES300 - PDF Owner's Manuals ; Gauges, Meters and Service Reminder Indicators. 9 pages ; Theft Deterrent. 4 pages. lexus es300 repair manual pdf Aug 1, 2009 — ES - 1st to 4th Gen (1990-2006) - lexus es300 repair manual pdf - hi does anyone has a link to a repair manual for a lexus es300 1996 free ...