



# Dishwashers

**Safety Instructions** ..... 2-3

**Operating Instructions**

Care and Cleaning ..... 11

Getting Started ..... 4-5

Loading and Place Settings ..... 8-9

Loading the silverware baskets ..... 10

Using the Dishwasher ..... 6-7

**Troubleshooting Tips** ..... 12-14

**Consumer Support**

Consumer Support ..... 16

Warranty ..... 15

**Owner's Manual**

Dishwashers  
ADT520 Series  
GDF510-540 Series  
GDT530-550 Series

## Lave-vaisselle

**Manuel d'utilisation**

La section française commence à la page 17

## Lavaplatos

**Manual del propietario**

La sección en español empieza en la página 33

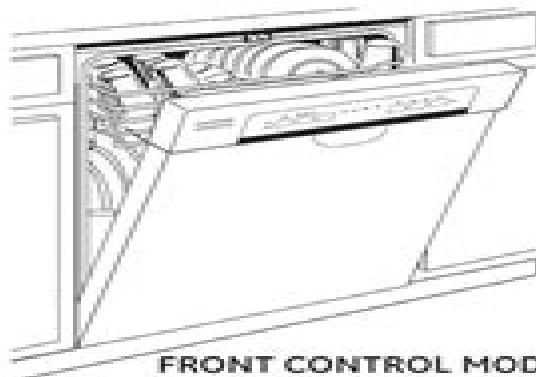

FRONT CONTROL MODELS

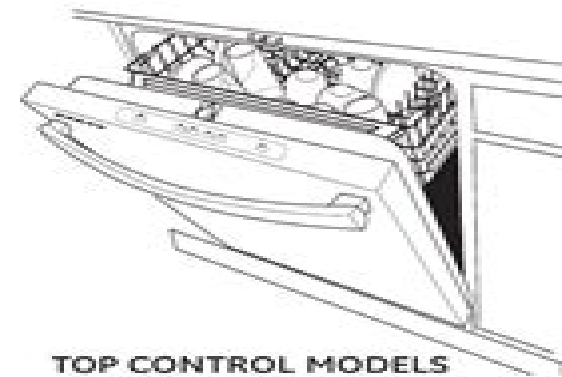

TOP CONTROL MODELS

Write the model and serial numbers here:

Model # \_\_\_\_\_

Serial # \_\_\_\_\_

You can find them on the tub wall just inside the door.

# General Electric Appliances Manual

**PT Brinkman**

A decorative graphic element consisting of a light blue horizontal bar with a rounded right end, and a red-to-white gradient semi-circle overlapping the right side of the bar.

## **General Electric Appliances Manual:**

This is likewise one of the factors by obtaining the soft documents of this **General Electric Appliances Manual** by online. You might not require more times to spend to go to the book start as without difficulty as search for them. In some cases, you likewise attain not discover the message General Electric Appliances Manual that you are looking for. It will completely squander the time.

However below, taking into consideration you visit this web page, it will be therefore categorically simple to get as competently as download lead General Electric Appliances Manual

It will not take many epoch as we tell before. You can do it even though be active something else at house and even in your workplace. suitably easy! So, are you question? Just exercise just what we find the money for under as capably as review **General Electric Appliances Manual** what you as soon as to read!

<https://staging.conocer.cide.edu/About/detail/fetch.php/la%20rubie%20et%20lexurb%20de%201914%20a%20nos%20jours.pdf>

## **Table of Contents General Electric Appliances Manual**

1. Understanding the eBook General Electric Appliances Manual
  - The Rise of Digital Reading General Electric Appliances Manual
  - Advantages of eBooks Over Traditional Books
2. Identifying General Electric Appliances Manual
  - Exploring Different Genres
  - Considering Fiction vs. Non-Fiction
  - Determining Your Reading Goals
3. Choosing the Right eBook Platform
  - Popular eBook Platforms
  - Features to Look for in an General Electric Appliances Manual
  - User-Friendly Interface

4. Exploring eBook Recommendations from General Electric Appliances Manual
  - Personalized Recommendations
  - General Electric Appliances Manual User Reviews and Ratings
  - General Electric Appliances Manual and Bestseller Lists
5. Accessing General Electric Appliances Manual Free and Paid eBooks
  - General Electric Appliances Manual Public Domain eBooks
  - General Electric Appliances Manual eBook Subscription Services
  - General Electric Appliances Manual Budget-Friendly Options
6. Navigating General Electric Appliances Manual eBook Formats
  - ePub, PDF, MOBI, and More
  - General Electric Appliances Manual Compatibility with Devices
  - General Electric Appliances Manual Enhanced eBook Features
7. Enhancing Your Reading Experience
  - Adjustable Fonts and Text Sizes of General Electric Appliances Manual
  - Highlighting and Note-Taking General Electric Appliances Manual
  - Interactive Elements General Electric Appliances Manual
8. Staying Engaged with General Electric Appliances Manual
  - Joining Online Reading Communities
  - Participating in Virtual Book Clubs
  - Following Authors and Publishers General Electric Appliances Manual
9. Balancing eBooks and Physical Books General Electric Appliances Manual
  - Benefits of a Digital Library
  - Creating a Diverse Reading Collection General Electric Appliances Manual
10. Overcoming Reading Challenges
  - Dealing with Digital Eye Strain
  - Minimizing Distractions
  - Managing Screen Time
11. Cultivating a Reading Routine General Electric Appliances Manual
  - Setting Reading Goals General Electric Appliances Manual
  - Carving Out Dedicated Reading Time

12. Sourcing Reliable Information of General Electric Appliances Manual
  - Fact-Checking eBook Content of General Electric Appliances Manual
  - Distinguishing Credible Sources
13. Promoting Lifelong Learning
  - Utilizing eBooks for Skill Development
  - Exploring Educational eBooks
14. Embracing eBook Trends
  - Integration of Multimedia Elements
  - Interactive and Gamified eBooks

### **General Electric Appliances Manual Introduction**

In this digital age, the convenience of accessing information at our fingertips has become a necessity. Whether its research papers, eBooks, or user manuals, PDF files have become the preferred format for sharing and reading documents. However, the cost associated with purchasing PDF files can sometimes be a barrier for many individuals and organizations. Thankfully, there are numerous websites and platforms that allow users to download free PDF files legally. In this article, we will explore some of the best platforms to download free PDFs. One of the most popular platforms to download free PDF files is Project Gutenberg. This online library offers over 60,000 free eBooks that are in the public domain. From classic literature to historical documents, Project Gutenberg provides a wide range of PDF files that can be downloaded and enjoyed on various devices. The website is user-friendly and allows users to search for specific titles or browse through different categories. Another reliable platform for downloading General Electric Appliances Manual free PDF files is Open Library. With its vast collection of over 1 million eBooks, Open Library has something for every reader. The website offers a seamless experience by providing options to borrow or download PDF files. Users simply need to create a free account to access this treasure trove of knowledge. Open Library also allows users to contribute by uploading and sharing their own PDF files, making it a collaborative platform for book enthusiasts. For those interested in academic resources, there are websites dedicated to providing free PDFs of research papers and scientific articles. One such website is Academia.edu, which allows researchers and scholars to share their work with a global audience. Users can download PDF files of research papers, theses, and dissertations covering a wide range of subjects. Academia.edu also provides a platform for discussions and networking within the academic community. When it comes to downloading General Electric Appliances Manual free PDF files of magazines, brochures, and catalogs, Issuu is a popular choice. This digital publishing platform hosts a vast collection of publications from around the world. Users can search for specific titles or explore various categories and genres. Issuu offers a seamless

reading experience with its user-friendly interface and allows users to download PDF files for offline reading. Apart from dedicated platforms, search engines also play a crucial role in finding free PDF files. Google, for instance, has an advanced search feature that allows users to filter results by file type. By specifying the file type as "PDF," users can find websites that offer free PDF downloads on a specific topic. While downloading General Electric Appliances Manual free PDF files is convenient, it's important to note that copyright laws must be respected. Always ensure that the PDF files you download are legally available for free. Many authors and publishers voluntarily provide free PDF versions of their work, but it's essential to be cautious and verify the authenticity of the source before downloading General Electric Appliances Manual. In conclusion, the internet offers numerous platforms and websites that allow users to download free PDF files legally. Whether it's classic literature, research papers, or magazines, there is something for everyone. The platforms mentioned in this article, such as Project Gutenberg, Open Library, Academia.edu, and Issuu, provide access to a vast collection of PDF files. However, users should always be cautious and verify the legality of the source before downloading General Electric Appliances Manual any PDF files. With these platforms, the world of PDF downloads is just a click away.

### **FAQs About General Electric Appliances Manual Books**

How do I know which eBook platform is the best for me? Finding the best eBook platform depends on your reading preferences and device compatibility. Research different platforms, read user reviews, and explore their features before making a choice. Are free eBooks of good quality? Yes, many reputable platforms offer high-quality free eBooks, including classics and public domain works. However, make sure to verify the source to ensure the eBook's credibility. Can I read eBooks without an eReader? Absolutely! Most eBook platforms offer web-based readers or mobile apps that allow you to read eBooks on your computer, tablet, or smartphone. How do I avoid digital eye strain while reading eBooks? To prevent digital eye strain, take regular breaks, adjust the font size and background color, and ensure proper lighting while reading eBooks. What's the advantage of interactive eBooks? Interactive eBooks incorporate multimedia elements, quizzes, and activities, enhancing the reader engagement and providing a more immersive learning experience. General Electric Appliances Manual is one of the best books in our library for free trial. We provide a copy of General Electric Appliances Manual in digital format, so the resources that you find are reliable. There are also many eBooks related to General Electric Appliances Manual. Where to download General Electric Appliances Manual online for free? Are you looking for General Electric Appliances Manual PDF? This is definitely going to save you time and cash in something you should think about. If you're trying to find them, search around online. Without a doubt, there are numerous of these available, and many of them have the freedom. However, without a doubt, you receive whatever you purchase. An alternate way to get ideas is always to check another General Electric

Appliances Manual. This method for see exactly what may be included and adopt these ideas to your book. This site will almost certainly help you save time and effort, money and stress. If you are looking for free books then you really should consider finding to assist you try this. Several of General Electric Appliances Manual are for sale to free while some are payable. If you arent sure if the books you would like to download works with for usage along with your computer, it is possible to download free trials. The free guides make it easy for someone to free access online library for download books to your device. You can get free download on free trial for lots of books categories. Our library is the biggest of these that have literally hundreds of thousands of different products categories represented. You will also see that there are specific sites catered to different product types or categories, brands or niches related with General Electric Appliances Manual. So depending on what exactly you are searching, you will be able to choose e books to suit your own need. Need to access completely for Campbell Biology Seventh Edition book? Access Ebook without any digging. And by having access to our ebook online or by storing it on your computer, you have convenient answers with General Electric Appliances Manual To get started finding General Electric Appliances Manual, you are right to find our website which has a comprehensive collection of books online. Our library is the biggest of these that have literally hundreds of thousands of different products represented. You will also see that there are specific sites catered to different categories or niches related with General Electric Appliances Manual So depending on what exactly you are searching, you will be able tochoose ebook to suit your own need. Thank you for reading General Electric Appliances Manual. Maybe you have knowledge that, people have search numerous times for their favorite readings like this General Electric Appliances Manual, but end up in harmful downloads. Rather than reading a good book with a cup of coffee in the afternoon, instead they juggled with some harmful bugs inside their laptop. General Electric Appliances Manual is available in our book collection an online access to it is set as public so you can download it instantly. Our digital library spans in multiple locations, allowing you to get the most less latency time to download any of our books like this one. Merely said, General Electric Appliances Manual is universally compatible with any devices to read.

### **Find General Electric Appliances Manual :**

[la rubie et lexurb de 1914 a nos jours](#)

[la politica del grano](#)

[la sans pareille](#)

[la tapiberie editiona refondue et augmentee](#)

**la preparation dun champion un essai sur la preparation a la performance sportive**

[la tarta voladora](#)



**la virgen de guadalupe**

*laboratory studies in zoology*

**laboratory manual for physical geography**

*la petite comedie francaise*

*la sante aux colonies*

*la societe du spectacle pb 1996*

**la question du quabec ebai ebai**

**laay die toten ruhen roman aus d amerikan v anke c burger**

**la tierra de los caciques**

**General Electric Appliances Manual :**

[henry mancini jazz piano solos series volume 38 sheet](#) - Dec 13 2022

web henry mancini jazz piano solos series volume 38 jazz piano solos softcover this folio features 20 songs from the beloved film and television composer in cool jazzy arrangements including baby elephant walk breakfast at tiffany s charade days of wine and roses in the arms of love mr lucky moment to moment moon

**free henry mancini sheet music musescore com** - May 18 2023

web sunflower henry mancini share download and print free henry mancini sheet music with the world s largest community of sheet music creators composers performers music teachers students beginners artists and other musicians with over 1 500 000 digital sheet music to play practice learn and enjoy

[henry mancini piano solos by mancini henry amazon com](#) - Jun 19 2023

web dec 1 2012 solo arrangements of more than 30 magnificent mancini hits includes baby elephant walk breakfast at tiffany s charade crazy world days of wine and roses how soon moon river newhart main title theme peter gunn the pink panther a shot in the dark the thorn birds main theme two for the road whistling away

[henry mancini henry mancini piano solos piano musicroom com](#) - Jun 07 2022

web solo piano arrangements of more than 30 magnificent mancini hits includes baby elephant walk breakfast at tiffany s charade crazy world days of wine and roses how soon moon river newhart main title theme peter gunn the pink panther a shot in the dark the thorn birds main theme two for the road

[henry mancini piano solos henry mancini google books](#) - Jul 08 2022

web piano solo composer collection solo arrangements of more than 30 magnificent mancini hits includes baby elephant walk breakfast at tiffany s charade crazy world days of wine and roses how soon moon river newhart main title theme peter gunn

the pink panther a shot in the dark the thorn birds main theme two for the  
[henry mancini sheet music for piano solo musescore com](#) - Aug 21 2023

web download and print in pdf or midi free sheet music for sunflower by henry mancini arranged by unregistered user for piano solo

**henry mancini piano solo sheet music** - Nov 12 2022

web henry mancini piano solo sheet music 208 items found show available instantly only ships via mail only sort by 1 2 3 4 next results per page 10 25 50 look inside listen watch moon river piano solo level 4 digital download by henry mancini by henry mancini arranged by rupert austin broadway jazz musical show standards

[henry mancini moon river piano solo youtube](#) - Sep 10 2022

web may 3 2017 this arrangement comes from henry mancini piano solos published by hal leonard the whole book is full of sweet and inventive intermediate arrangements c

**henry mancini jazz piano solos 38 amazon com** - Jan 02 2022

web dec 1 2015 this folio features 20 songs from the beloved film and television composer in cool jazzy arrangements including baby elephant walk breakfast at tiffany s charade days of wine and roses in the arms of love mr lucky moment to moment moon river peter gunn the pink panther the thorn birds main theme two for the road and more

**henry mancini piano solos j w pepper** - Apr 17 2023

web description number level price qty currently viewing piano upc 884088617455 publisher id 00313616 10348402 i 24 99 full song list anywhere the heart goes arabesque baby elephant walk breakfast at tiffany s charade a cool shade of blue crazy world darling lili days of wine and roses dear

**henry mancini piano solos by henry mancini sheet music scribd** - Jul 20 2023

web dec 1 2012 what people think about henry mancini piano solos 4 4 33 ratings 0 reviews henry mancini piano solos sheet music by henry mancini with a free trial access millions of ebooks and audiobooks and sheet music on

[henry mancini piano solos sheet music plus](#) - Jan 14 2023

web henry mancini piano solos by book only sheet music for piano buy print music bt hl00313616 shop and buy henry mancini piano solos sheet music piano sheet music book by hal leonard at sheet music plus bt hl00313616 world s largest sheet music selection skip to main content select your flag albania argentina australia

[henry mancini piano solos by henry mancini piano solo sheet](#) - Sep 22 2023

web solo arrangements of more than 30 magnificent mancini hits includes baby elephant walk breakfast at tiffany s charade crazy world days of wine and roses how soon moon river newhart main title theme peter gunn the pink panther a shot in the dark the thorn birds main theme two for the road

*moment to moment henry mancini piano solos scribd* - May 06 2022

web dec 1 2012 moment to moment henry mancini piano solos by henry mancini 4 5 5 33 ratings 5 pages this is song 21 of 32 from henry mancini piano solos piano solo composer collection piano solo arrangements of more than 30 magnificent mancini hits includes baby elephant walk breakfast at tiffany s charade crazy world

**henry mancini piano solos kindle edition amazon com** - Dec 01 2021

web dec 1 2012 piano solo arrangements of more than 30 magnificent mancini hits includes baby elephant walk breakfast at tiffany s charade crazy world days of wine and roses how soon moon river newhart main title theme peter gunn the pink panther a shot in the dark the thorn birds main theme two for the road

**henry mancini dreamsville piano solo youtube** - Mar 04 2022

web oct 20 2017 henry mancini dreamsville piano solo another entry from the hal leonard book of arrangements henry mancini piano solos i really like all the inner voices in this one check out my other

**henry mancini moon river piano solo youtube** - Aug 09 2022

web may 24 2012 henry mancini moon river piano solo adam messina 3 3k subscribers 774k views 11 years ago this is moon river by henry mancini arrangement by mercuzio you can find his channel and free

[henry mancini jazz piano solos series volume 38 scribd](#) - Apr 05 2022

web this folio features 20 songs from the beloved film and television composer in cool jazzy piano arrangements including baby elephant walk breakfast at tiffany s charade days of wine and roses in the arms of love mr lucky moment to moment moon river peter gunn the pink panther the thorn birds main theme two for the

*henry mancini piano solos piano solo composer collection* - Oct 23 2023

web henry mancini piano solos anywhere the heart goes from the thorn birds arabesque baby elephant walk from the paramount picture hatari breakfast at tiffany s theme from the paramount picture breakfast at tiffany s charade from charade a cool shade

*piano and strings henry mancini musescore com* - Mar 16 2023

web download and print in pdf or midi free sheet music for piano and strings by henry mancini arranged by chapeau canotier for piano solo

[henry mancini by henry mancini piano solo sheet music](#) - Feb 15 2023

web jazz piano solos series this folio features 20 songs from the beloved film and television composer in cool jazzy arrangements including baby elephant walk breakfast at tiffany s charade days of wine and roses in the arms of love mr lucky moment to moment moon river peter gunn the pink panther the

**henry mancini jazz piano solos series volume 38 kindle edition** - Feb 03 2022

web dec 1 2015 henry mancini jazz piano solos series volume 38 kindle edition by henry mancini author format kindle edition 4 0 22 ratings part of jazz piano solos 63 books see all formats and editions kindle 18 99 read with our free app paperback 19 99 1 used from 14 96 9 new from 15 70 piano solo songbook

[henry mancini piano solos henry mancini google books](#) - Oct 11 2022

web piano solo composer collection piano solo arrangements of more than 30 magnificent mancini hits includes baby elephant walk breakfast at tiffany s charade crazy world days of

**american english for english language teachers** - Jul 06 2023

web american english file second edition retains the popular methodology developed by world renowned authors christina latham koenig and clive oxenden language

**uruguay reflects latin american drift from u s turn to china** - Mar 02 2023

web 1 hour ago reece james has risked his euro 2024 place according to gareth southgate by making himself unavailable for the upcoming international break southgate has

[level 1 downloads american english file oxford university press](#) - Aug 15 2021

web nov 9 2023 he said the us sought a pathway to israelis and palestinians living side by side in states of their own with equal measures of security freedom opportunity and

[american english file adults young adults oxford university](#) - Nov 29 2022

web nov 5 2023 side definition the side of something is a position to the left or right of it rather than in front of meaning pronunciation translations and examples in american

*balletboyz england on fire review riotous tour through a* - Sep 27 2022

web introducing the new edition of the most popular american english series in the world side by side extra edition is a new and improved version that also includes lifeskills content

[henry taylor b side review a contemporary brush with genius](#) - May 04 2023

web american english file third edition builds on tried and trusted methodology and contains uniquely motivating lessons and activities that encourage students to discuss topics with

**boy charged with murder of leeds teenager alfie lewis england** - Mar 22 2022

web side by side extra 1e level 2 student book ebook digital resources side by side extra 1e level 2 workbook digital resources side by side extra 1e level 3 student ebook

**us launches airstrike in response to attacks on bases housing** - Jun 12 2021

web american english file 1 student s book second edition american english file 1 student s book second edition american english file 1 student s book second edition zoom in thumbnails backward first previous page next page last forward more

search search ads

*side by side book 1a english through guided conversations* - Oct 05 2020

*american english file learning resources oxford university* - Oct 09 2023

web students american english file access and download class audio workbook audio and all video for the american english file second edition find resources for american

**amazon com the american side** - Sep 08 2023

web select the department you want to search in

**american english file 2nd edition studentbook 1 pdf slideshare** - Jan 08 2021

web 25 minutes ago england s chief medical officer prof chris whitty has called for a cultural shift in medicine away from maximising lifespan and towards improving quality of life in

**american english file level 1 oxford university press** - Apr 03 2023

web samantha pearson nov 8 2023 5 30 am et listen 2 min montevideo uruguay welcome to the people s republic of china the name of a gleaming new

*november is typically the best month for stocks so far it s* - Dec 07 2020

web jan 1 1983 side by side international version 1 third edition 81 00 only 1 left in stock order soon from the side by side english program level 1a is a workbook for adults

**reece james euro 2024 spot at risk after he opts out of qualifiers** - Feb 01 2023

web american english file second edition tests levels starter to 3 only a new test for every file is now available and includes listening grammar and vocabulary reading and

american english file level 1 student book amazon com tr - Jun 05 2023

web 1 day ago for all the curators academics gallerists advisers collectors and yes critics who might play a role in a painting s life it is at the end the most approachable of forms

**janet yellen to host china s top economic official ahead of** - Jul 26 2022

web 12 hours ago philadelphia swept the best of three series with new england to advance to the eastern conference semifinals they will face cincinnati the east s no 1 seed and

best ski resorts in america for every skier wsj rankings wsj - Oct 17 2021

web american english file level 1 downloads audio student book level 1 sb file 1 zip 84 mb level 1 sb file 2 zip 36 mb level 1 sb files 3 4 zip 92 mb level 1 sb files 5 6 an american police officer zip 30 mb review and check 5 6 williamsburg new york zip 29 mb review and check 7 8 edinburgh castle

*american english file 1 student s book second edition anyflip* - Apr 10 2021

web nov 5 2023 aside definition if you move something aside you move it to one side of you meaning pronunciation translations and examples in american english

*side definition in american english collins english* - Oct 29 2022

web 10 hours ago at its best england on fire reaches towards an alan garner ish melding of place spirit and symbol or taps a punk rock energy or maybe most english of all in

**black babies in england three times more likely to die than white** - Nov 17 2021

web latest edition language american english age range jhs university adult level beginner pre intermediate toeic 250 350 cefr a1 b1 number of

**side by side extra english language teaching pearson** - Feb 18 2022

web executive summary some of the immediate pressures from the global energy crisis have eased but energy markets geopolitics and the global economy are unsettled and the

**aside definition in american english collins english dictionary** - Feb 06 2021

web nov 3 2023 the yield on the 10 year us treasury note fell on thursday to 4 67 compared to wednesday s close of 4 79 well below the key 5 level it breached last

**mls playoffs philadelphia sweep new england to reach eastern** - May 24 2022

web 15 hours ago a 14 year old boy has been charged with murdering alfie lewis a 15 year old boy who was stabbed near a school in leeds alfie was attacked in the horsforth

**side by side extra edition longman esl** - Aug 27 2022

web 22 hours ago us treasury secretary janet yellen l shakes hands with chinese vice premier he lifeng during a meeting at the diaoyutai state guesthouse in beijing on july

[american english file 3e](#) - Apr 22 2022

web side by side extra is an enhanced version of the classic side by side program a dynamic all skills program that builds students general language proficiency real life

**executive summary world energy outlook 2023 analysis iea** - Dec 19 2021

web 3 hours ago 9 big sky resort montana 10 breckenridge resort colorado full rankings and methodology available here to help you cut to the chase we pored over mountains

**american english file 3rd edition eltbooks com** - Mar 10 2021

web mar 17 2022 american english file 2nd edition studentbook 1 download as a pdf or view online for free submit search upload american english file 2nd edition

*side by side extra level 1* - Jul 14 2021

web practise your grammar vocabulary pronunciation listening and reading and have some fun too select your edition and level below beginner elementary pre intermediate

[side by side extra edition student book and etext level 1](#) - Sep 15 2021

web products adult education side by side extra level 1 side by side extra level 1 description additional information side by side extra is an enhanced version of the

*prioritise quality of life over prolonging it for elderly chris whitty* - Nov 05 2020

**english file learning resources oxford university press** - May 12 2021

web new and updated texts topics and listenings based on feedback from american english file teachers new teacher resource center allows you to manage all course resources and teaching materials in one place online new video listening activity integrated into each even numbered file these short documentaries and dramas make class time more

**american english file teacher s site teaching resources** - Dec 31 2022

web buy from home elt catalog teaching adults young adults american english file american english file gets you talking third edition christina latham koenig clive

**side by side extra plus adult english language** - Jun 24 2022

web create one now with your access code for american english file 3e help and support oxford online practice is an online course component for english language teaching

*buy pearson ell products side by side* - Jan 20 2022

web 8 hours ago black babies in england are almost three times more likely to die than white babies after death rates surged in the last year according to figures that have led to

[the hijacking of american flight 119 review take the money](#) - Aug 07 2023

web nov 9 2023 6 01 pm et photo alamy stock photo d b cooper belongs in the pantheon of american desperados a jesse james or billy the kid for our times on nov 24

[national building code of fiji 1990 pdf](#) - Oct 27 2022

web national building code of fiji 1990 i saw the power that created the world in action apr 30 2020 i am taniela tabu the author of my christian testimony a true story of my life from childhood to economic impact of tourism in fiji 1990 apr 22 2022 fiji budget estimates jul 26 2022 the architecture of democracy dec 27 2019

**building code and standards guidance fiji case study** - Dec 29 2022

web fiji the regional diagnostic study on the application of building codes in the pacific investigates the capacity of pacific

countries to apply building codes or building construction specifications and standards and provides guidance in future assistance related to building code updates

*national building code of fiji 1990 download only japanalert* - Mar 20 2022

web national building code the enabling environment for disaster risk financing in fiji the international yearbook of environmental and resource economics 2003 2004

a partial commentary on the national building code fiji 1990 - Jun 03 2023

web a partial commentary on the national building code fiji 1990 pacific regional infrastructure facility prif

building code unrevised for 29 years council fiji sun - Feb 28 2023

web feb 23 2020 the national building code has not been revised for the past 29 years the construction industry council of fiji said council chief executive officer vijay naidu made the comment at the second annual real estate agents licencing board realb conference in pacific harbour past week

**national building code of fiji 1990 download only** - Jan 30 2023

web control systems building code of the city of new york jan 04 2022 state building construction code applicable to general building construction november 30 1979 jul 10 2022 national building codes handbook may 20 2023 contractors will find everything they need to know to meet building code guidelines and pass inspections in all parts of

**building codes pacific regional infrastructure facility prif** - Sep 06 2023

web a partial commentary on the national building code fiji 1990 fiji building code home building manual fiji 1990 kiribati national building code of kiribati niue niue national building code 1990 republic of marshall islands rmi national building code of the republic of the marshall islands 2021 samoa national building code of samoa 2017

**public health national building code regulations 2004 laws of fiji** - Sep 25 2022

web the office the fijian government and all employees and agents of the office and or of the fijian government will not be responsible or liable for any loss damage or injury including death however caused whether caused by any negligent or other unlawful act or omission of by or on the part of the office the fijian government or any agent

*welcome to pacific regional infrastructure facility prif pacific* - Aug 05 2023

web the national building code for fiji nbcf is a comprehensive document that sets out the standards and requirements for the design construction and maintenance of buildings in fiji it covers various aspects of building safety health and amenity as well as environmental and energy efficiency considerations the nbcf was developed by the

*mims gov fj* - Nov 27 2022

web the building code has not been updated since 1990 building techniques materials and construction practices have changed considerably since then and standards need to reflect new approaches to health safety and environment the building



code update will address three primary priorities of concern sustainability inclusion and innovation

*[national building code of fiji pdf slideshare](#)* - May 02 2023

web apr 6 2016 download now national building code of fiji download as a pdf or view online for free

**[national building code of fiji 1990 full pdf dna viz tpq](#)** - Apr 20 2022

web national building code of fiji 1990 1 omb no 1241598734352 national building code of fiji 1990 profile on occupational safety and health in fiji the south pacific journal of natural science integrated research on disaster risks development strategy for fiji making climate action more effective disaster mitigation in asia and the pacific

**[national building code of fiji 1990 2022 portal nivbook co](#)** - Feb 16 2022

web national building code of fiji 1990 annual report pacific economic monitor december 2017 congressional presentation fiji

national report to unced living with risk development strategy for fiji fiji ecology nature protection laws and regulations

handbook the south pacific journal of natural science accessibility for all human

*[national building code of fiji 1990 pdf clr imymac](#)* - Aug 25 2022

web national building code of fiji 1990 a partial commentary on the national building code fiji foreign operations export

financing and related programs appropriations for 1989

*[fiji building code pacific regional infrastructure facility prif](#)* - Oct 07 2023

web the nbcf was originally published in 1990 with an accompanying partial commentary to explain the more complex provisions of the code and a companion home building manual fiji hbmf

*[national building code of fiji 1990 pdf uniport edu](#)* - May 22 2022

web sep 29 2023 national building code of fiji 1990 3 5 downloaded from uniport edu ng on september 29 2023 by guest included covering 88 countries which comprise about 80 of the inhabited land mass of the earth over 100 maps international books in print 1998 building a research base in tourism 1993

*[national building code of fiji 1990 download only](#)* - Jul 24 2022

web national building code of fiji 1990 the enabling environment for disaster risk financing in fiji accessibility for all integrated research on disaster risks creating resilient landscapes in an era of climate change probabilistic earthquake hazard assessment for fiji the practice of earthquake hazard assessment renewable energy readiness

*[update to the fiji national building code ministry of](#)* - Jul 04 2023

web the building code has not been updated since 1990 building techniques materials and construction practices have changed considerably since then and standards need to reflect new approaches to health safety and the environment the building code update will address three primary priorities of concern sustainability inclusion and innovation

*[national building code of fiji 1990 pqr uiaf gov co](#)* - Jun 22 2022

web as acuteness of this national building code of fiji 1990 can be taken as skillfully as picked to act living with risk international strategy for disaster reduction 2004 this publication published in 2 volumes not sold separately by tso is intended for people who have an interest in and practice disaster risk

national building code of fiji 1990 2023 - Apr 01 2023

web a new constitution was drawn up to replace the one adopted at independence in 1970 the 1990 constitution contained provisions for its own review within seven years section 161 the review was eventually 2 commissioned in march 1995 and reported in september 1996