

**GENERAC®**

MODELS: 005622-0, 005623-0

# Owner's Manual

## GP Series Portable Generator

**2 YEAR  
LIMITED  
WARRANTY**

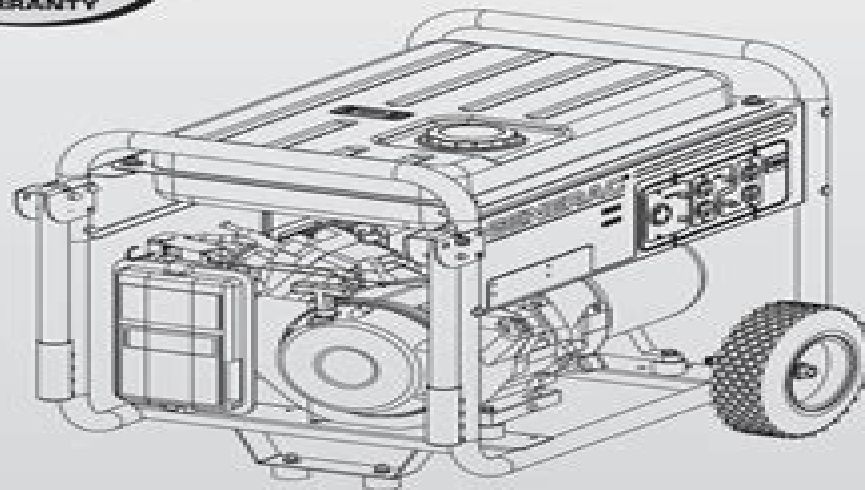

[www.generac.com](http://www.generac.com) or 1-888-436-3722

# Generac Gp5000 Manual

**Generac Power Systems**



## **Generac Gp5000 Manual:**

This is likewise one of the factors by obtaining the soft documents of this **Generac Gp5000 Manual** by online. You might not require more become old to spend to go to the books inauguration as with ease as search for them. In some cases, you likewise complete not discover the broadcast Generac Gp5000 Manual that you are looking for. It will very squander the time.

However below, bearing in mind you visit this web page, it will be therefore categorically easy to acquire as without difficulty as download guide Generac Gp5000 Manual

It will not recognize many time as we tell before. You can accomplish it though play a role something else at home and even in your workplace. fittingly easy! So, are you question? Just exercise just what we pay for under as well as evaluation **Generac Gp5000 Manual** what you taking into account to read!

<https://staging.conocer.cide.edu/data/book-search/HomePages/managing%20and%20troubleshooting%20pcs%20quiz%20answers.pdf>

## **Table of Contents Generac Gp5000 Manual**

1. Understanding the eBook Generac Gp5000 Manual
  - The Rise of Digital Reading Generac Gp5000 Manual
  - Advantages of eBooks Over Traditional Books
2. Identifying Generac Gp5000 Manual
  - Exploring Different Genres
  - Considering Fiction vs. Non-Fiction
  - Determining Your Reading Goals
3. Choosing the Right eBook Platform
  - Popular eBook Platforms
  - Features to Look for in an Generac Gp5000 Manual
  - User-Friendly Interface

4. Exploring eBook Recommendations from Generac Gp5000 Manual
  - Personalized Recommendations
  - Generac Gp5000 Manual User Reviews and Ratings
  - Generac Gp5000 Manual and Bestseller Lists
5. Accessing Generac Gp5000 Manual Free and Paid eBooks
  - Generac Gp5000 Manual Public Domain eBooks
  - Generac Gp5000 Manual eBook Subscription Services
  - Generac Gp5000 Manual Budget-Friendly Options
6. Navigating Generac Gp5000 Manual eBook Formats
  - ePub, PDF, MOBI, and More
  - Generac Gp5000 Manual Compatibility with Devices
  - Generac Gp5000 Manual Enhanced eBook Features
7. Enhancing Your Reading Experience
  - Adjustable Fonts and Text Sizes of Generac Gp5000 Manual
  - Highlighting and Note-Taking Generac Gp5000 Manual
  - Interactive Elements Generac Gp5000 Manual
8. Staying Engaged with Generac Gp5000 Manual
  - Joining Online Reading Communities
  - Participating in Virtual Book Clubs
  - Following Authors and Publishers Generac Gp5000 Manual
9. Balancing eBooks and Physical Books Generac Gp5000 Manual
  - Benefits of a Digital Library
  - Creating a Diverse Reading Collection Generac Gp5000 Manual
10. Overcoming Reading Challenges
  - Dealing with Digital Eye Strain
  - Minimizing Distractions
  - Managing Screen Time
11. Cultivating a Reading Routine Generac Gp5000 Manual
  - Setting Reading Goals Generac Gp5000 Manual
  - Carving Out Dedicated Reading Time

12. Sourcing Reliable Information of Generac Gp5000 Manual
  - Fact-Checking eBook Content of Generac Gp5000 Manual
  - Distinguishing Credible Sources
13. Promoting Lifelong Learning
  - Utilizing eBooks for Skill Development
  - Exploring Educational eBooks
14. Embracing eBook Trends
  - Integration of Multimedia Elements
  - Interactive and Gamified eBooks

### **Generac Gp5000 Manual Introduction**

In today's digital age, the availability of Generac Gp5000 Manual books and manuals for download has revolutionized the way we access information. Gone are the days of physically flipping through pages and carrying heavy textbooks or manuals. With just a few clicks, we can now access a wealth of knowledge from the comfort of our own homes or on the go. This article will explore the advantages of Generac Gp5000 Manual books and manuals for download, along with some popular platforms that offer these resources. One of the significant advantages of Generac Gp5000 Manual books and manuals for download is the cost-saving aspect. Traditional books and manuals can be costly, especially if you need to purchase several of them for educational or professional purposes. By accessing Generac Gp5000 Manual versions, you eliminate the need to spend money on physical copies. This not only saves you money but also reduces the environmental impact associated with book production and transportation. Furthermore, Generac Gp5000 Manual books and manuals for download are incredibly convenient. With just a computer or smartphone and an internet connection, you can access a vast library of resources on any subject imaginable. Whether you're a student looking for textbooks, a professional seeking industry-specific manuals, or someone interested in self-improvement, these digital resources provide an efficient and accessible means of acquiring knowledge. Moreover, PDF books and manuals offer a range of benefits compared to other digital formats. PDF files are designed to retain their formatting regardless of the device used to open them. This ensures that the content appears exactly as intended by the author, with no loss of formatting or missing graphics. Additionally, PDF files can be easily annotated, bookmarked, and searched for specific terms, making them highly practical for studying or referencing. When it comes to accessing Generac Gp5000 Manual books and manuals, several platforms offer an extensive collection of resources. One such platform is Project Gutenberg, a nonprofit organization that provides over 60,000 free eBooks. These books are primarily in the public domain, meaning they can be freely distributed and downloaded. Project Gutenberg offers a wide range of classic

literature, making it an excellent resource for literature enthusiasts. Another popular platform for Generac Gp5000 Manual books and manuals is Open Library. Open Library is an initiative of the Internet Archive, a non-profit organization dedicated to digitizing cultural artifacts and making them accessible to the public. Open Library hosts millions of books, including both public domain works and contemporary titles. It also allows users to borrow digital copies of certain books for a limited period, similar to a library lending system. Additionally, many universities and educational institutions have their own digital libraries that provide free access to PDF books and manuals. These libraries often offer academic texts, research papers, and technical manuals, making them invaluable resources for students and researchers. Some notable examples include MIT OpenCourseWare, which offers free access to course materials from the Massachusetts Institute of Technology, and the Digital Public Library of America, which provides a vast collection of digitized books and historical documents. In conclusion, Generac Gp5000 Manual books and manuals for download have transformed the way we access information. They provide a cost-effective and convenient means of acquiring knowledge, offering the ability to access a vast library of resources at our fingertips. With platforms like Project Gutenberg, Open Library, and various digital libraries offered by educational institutions, we have access to an ever-expanding collection of books and manuals. Whether for educational, professional, or personal purposes, these digital resources serve as valuable tools for continuous learning and self-improvement. So why not take advantage of the vast world of Generac Gp5000 Manual books and manuals for download and embark on your journey of knowledge?

## **FAQs About Generac Gp5000 Manual Books**

**What is a Generac Gp5000 Manual PDF?** A PDF (Portable Document Format) is a file format developed by Adobe that preserves the layout and formatting of a document, regardless of the software, hardware, or operating system used to view or print it. **How do I create a Generac Gp5000 Manual PDF?** There are several ways to create a PDF: Use software like Adobe Acrobat, Microsoft Word, or Google Docs, which often have built-in PDF creation tools. Print to PDF: Many applications and operating systems have a "Print to PDF" option that allows you to save a document as a PDF file instead of printing it on paper. Online converters: There are various online tools that can convert different file types to PDF. **How do I edit a Generac Gp5000 Manual PDF?** Editing a PDF can be done with software like Adobe Acrobat, which allows direct editing of text, images, and other elements within the PDF. Some free tools, like PDFescape or Smallpdf, also offer basic editing capabilities. **How do I convert a Generac Gp5000 Manual PDF to another file format?** There are multiple ways to convert a PDF to another format: Use online converters like Smallpdf, Zamzar, or Adobe Acrobats export feature to convert PDFs to formats like Word, Excel, JPEG, etc. Software like Adobe Acrobat, Microsoft Word, or other PDF editors may

have options to export or save PDFs in different formats. **How do I password-protect a Generac Gp5000 Manual PDF?** Most PDF editing software allows you to add password protection. In Adobe Acrobat, for instance, you can go to "File" -> "Properties" -> "Security" to set a password to restrict access or editing capabilities. Are there any free alternatives to Adobe Acrobat for working with PDFs? Yes, there are many free alternatives for working with PDFs, such as: LibreOffice: Offers PDF editing features. PDFsam: Allows splitting, merging, and editing PDFs. Foxit Reader: Provides basic PDF viewing and editing capabilities. How do I compress a PDF file? You can use online tools like Smallpdf, ILovePDF, or desktop software like Adobe Acrobat to compress PDF files without significant quality loss. Compression reduces the file size, making it easier to share and download. Can I fill out forms in a PDF file? Yes, most PDF viewers/editors like Adobe Acrobat, Preview (on Mac), or various online tools allow you to fill out forms in PDF files by selecting text fields and entering information. Are there any restrictions when working with PDFs? Some PDFs might have restrictions set by their creator, such as password protection, editing restrictions, or print restrictions. Breaking these restrictions might require specific software or tools, which may or may not be legal depending on the circumstances and local laws.

### **Find Generac Gp5000 Manual :**

[managing and troubleshooting pes quiz answers](#)

[maneb 2010 msce results](#)

[manipal sample papers](#)

**manometer problems answers**

[mankiw macroeconomics chapter 1](#)

[manual air pump diagram parts list](#)

[mandrin les trois bandits tome](#)

[manitou telehandler mlt 2313 parts manual](#)

**manual 2vip scooter**

[manhood quot hittin it quot 1](#)

**maneb pslc 2013 2014**

[manual 8 inch snow moisture tube](#)

[manitowoc 4000w crane operators manual](#)

[manual 1999 suzuki quad runner 500](#)

[manual 20jetta vr6](#)



**Generac Gp5000 Manual :**

Infor Lawson Enterprise Applications User and Administration ... Infor Lawson Enterprise Applications User and Administration Library - (On-premises) · Multiple Topics Found · Infor Help Library. Lawson manuals - LawsonGuru.com Forums - LawsonGuru.com Mar 14, 2008 — Lawson's documentation is available on their support site, and includes user manuals for all of their applications. Most organizations also ... Manuals - Kinsey USER GUIDES. 2022/2023 User Guides ... Document containing setup and reporting instructions related to Transaction Auditing for both Lawson S3 and Landmark. Asset Management User Guide Lawson® does not warrant the content of this document or the results of its use. Lawson may change this document without notice. Export Notice: Pursuant to your ... V10 Power User Basics for Infor Lawson - The Commons Oct 24, 2016 — Links to reference guides for each module are provided. Page 4. V10 POWER USER BASICS FOR INFOR LAWSON. 10/24/2016. Intro to Lawson for Total Beginners - YouTube Lawson ERP Software - Introduction - Surety Systems Lawson ERP Software - Intro Guide ... Lawson enterprise resource planning (ERP) is a software platform that provides software and services to ... Lawson S3 Integration with OnBase - KeyMark Inc Enhanced user experience; Simplifies approvals by eliminating manual actions; Little or no additional training; Integrated solution across your entire ... Lawson ERP Software | Infor S3 and Infor M3 - Dynamics 365 The Infor M3 software is designed to help enterprises that make, move, or maintain processes. It is what makes the system M3. It is a cloud-based ERP system ... Summa S3 User Guide - Grimco Connect Lawson · Design Help. Summa S3 User Guide. S3 User Guide. Related articles. Summa GoSign tutorial / Print & Cut workflow with CorelDRAW · Summa GoSign Tutorial ... NJ Corrections Exam - Practice Test, Preparation & Tips Applying to the NJ Department of Corrections? JobTestPrep will prep you for the Corrections Exam with practice tests & study guides. How to Pass the New Jersey Correctional Officer ... Pass the New Jersey Correctional Officer Test | Online Test Prep Course, Study Guide and Practice Tests | Covers all Corrections Officer Test Topics ... New Jersey Correctional Officer Test | Online 2023 ... Study and pass the 2023 New Jersey Correctional Officer Test! Practice questions, flashcards, full-length exams, study guides, and more! 2022 County Correctional Police Sergeant ... The information in this guide and the General Multiple-Choice Exam Orientation Guide. (available via CSC's website at <https://www.nj.gov/csc/seekers/jobs/> ... State Correctional Police Officer NJ LEE Exam ... CCS Test Prep® provides the best and most focused prep for the New Jersey State Correctional Police Officer Exam. Register for prep today! NJ DOC Promotional Course Get prepared for the New Jersey Civil Service Commission's NJ DOC Promotional Exam. Course includes free management and supervision study guide, ... New Jersey Correction Officer Exam This practice test includes 160 questions about New Jersey Correction Officer Exam. The test has been carefully developed to assist you to pass your actual test ... Correctional Officer Test This practice test is divided into three (3) areas: General Knowledge; Basic Skills; and Career-Specific Aptitude on professional standards, facility operations ... New Jersey Exam Study Guide Criminal Justice ... Feb 22, 2023 — It consists of hundreds of questions testing

your knowledge of the statutes, cases and rules related to criminal law, along with comprehensive ... New Jersey Law Enforcement Exam Interactive ... New Jersey Law Enforcement Examination (LEE) Interactive Online Practice Test. \$17.50. The NJ LEE Practice Test contains 70 questions that assess the job- ... Grammersense3 SB Anskey 2 | PDF | Mount Everest Student Book 3 Answer Key. Oxford University Press Grammar Sense 3/Answer Key 1. CHAPTER 1. A3: After You Read (p. 5) 2. T ... Grammersense3 SB Anskey 2 PDF Grammar Sense. Student Book 3 Answer Key. B2: Working on Verb Forms (p. 9) CHAPTER 1. SIMPLE PRESENT A3: After You Read (p. 5) BASE FORM PRESENT CONTINUOUS Grammar Sense 3 Student Online Practice A comprehensive, four-level American English grammar practice series that gives learners a true understanding of how grammar is used in authentic contexts. Part ... Ebook free Grammar sense 3 answer key file type ... - resp.app Jun 23, 2023 — Yeah, reviewing a book grammar sense 3 answer key file type could build up your near links listings. This is just one of the solutions for ... Grammar Sense 3 - Continuous Improvement ... answer is simple. No surgeon will ever be able to keep his or her hand as steady as the hand of a robot. No surgeon is ever being able to greatly magnify a. Grammar sense 3. Teacher's book : Sherak, Katharine Jul 9, 2021 — Grammar sense 3. Teacher's book. by: Sherak, Katharine. Publication date: 2012. Topics: English language -- Textbooks for foreign speakers ... Grammar Sense 3 Student Book with Online Practice ... Key features. Grammar Instruction Engaging reading texts, comprehensive grammar ... Looking for a sensible solution for teaching grammar? View Course. Part of ... 5 The Present Perfect Continuous Find the error in each sentence and correct it. 1. Grammar Sense 3 Test: Chapter 5 ... Grammar Sense 3 Answer Key: Chapter 5. © Oxford University Press. 5 Answer ... Grammar Sense 3 Pdf - Fill Online, Printable, Fillable, Blank Fill Grammar Sense 3 Pdf, Edit online. Sign, fax and printable from PC, iPad, tablet or mobile with pdfFiller  Instantly. Try Now!