

GENERAC

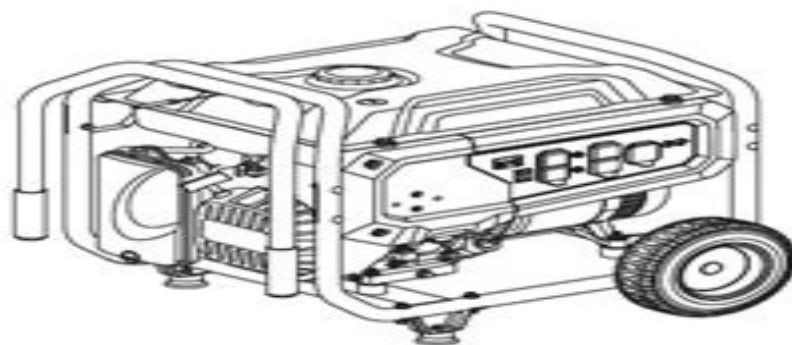

Generac Generator Gp6500 Manual

Caterpillar Inc. Peoria, Ill..



Generac Generator Gp6500 Manual:

Generac Service and Repair Manual Generac Power Systems,1999 **MEP 805B / 815B Generator Set Repair Parts Manual TM 9-6115-671-24P** Brian Greul,2021-05-22 The MEP series of Military Generators are rugged durable and incorporate proven diesel engine technology This book is the generator set repair parts manual and also incorporates general support instructions It is being republished to assist enthusiasts restorers and aftermarket owners who use or wish to use these generators outside of military use **MEP 804A/B and 814A/B 15 KW Generator Set Manual TM 9-6115-643-10** Brian Greul,2021-03-13 The MEP series of Military Generators are reknowned for their quiet durable operation and conservative power ratings This is the operators manual for the 15KW version of the generator issued under models 804 and 814 The A series has analog controls and the B series has digital controls Various units are manufactured for the US Government by different contractors with different power plants This book is a reprint of the operator manual published by the US Army It is printed as a courtesy to enthusiasts and owners of these generator sets Other important manuals for this generator are also printed by this publisher Operator's and Unit Maintenance Manual ,1987 **Electric Generator Maintenance - Repair Manual** P. S. Publishing,2024-01-25 Electric Generator Maintenance Repair Manual is your go to resource for ensuring the reliable operation of electric generators From routine maintenance tasks to troubleshooting and repair procedures this comprehensive manual covers everything you need to know to keep your generator running smoothly With step by step instructions and helpful tips you ll learn how to identify and address common issues prolonging the lifespan of your generator and minimizing downtime Whether you re a professional technician or a DIY enthusiast this manual is an indispensable tool for maintaining your electric generator *Maintenance Manual for Diesel-electric Generator Sets Models-6016B-C-D-E* General Motors Corporation. Detroit Diesel Engine Division,1945 **TECHNICAL MANUAL... OPERATOR, ORGANIZATIONAL, DIRECT SUPPORT AND GENERAL SUPPORT..., GENERATOR SET, GASOLINE ENGINE DRIVEN..., DEPARTMENT OF DEFE** ,2004* **GS Maintenance Manual** ,1992 **Troubleshooting and Repair Manual, Generator Sets** Cummins Engine Company,1987 **Operator's Manual** United States. Department of the Army,1961 **The Adams Pulsed Motor Generator Manual** ,1993 **GS Maintenance Manual** ,1988 MEP 701A 3KW Generator Pair Operators and Maintenance Manual TM 5-6115-640-14&P Includes Repair Parts and Special Tools List Brian Greul,2021-05-23 The MEP series of Military Generators are rugged durable and incorporate proven diesel engine technology This book is the the combined Operator Maintenance and Parts List Manual It is being republished to assist enthusiasts restorers and aftermarket owners who use or wish to use these generators outside of military use Technical Manual for Two Tone Generator Model TTTG-1 Technical Materiel Corporation (Canada) Limited,1974 **FUELING FIXTURE AND GENERATOR INSTRUCTIONS. Technical Manual for SNAP 13** ,1964 Electric Dynamometer Generator Megatech Corporation,1972 **Instruction Manual for Brushless A.c. Generator** , **Service Manual** Caterpillar

Inc. Peoria, Ill., 1985 **Training Chart Manual Section M** General Motors Corporation. Delco-Remy Division, 1963
Instruction Manual and Experiments for Motor Generator Trainer EC 613-00 Electronic Controls Limited, 1968

The Engaging Realm of E-book Books: A Detailed Guide Unveiling the Benefits of E-book Books: A World of Convenience and Flexibility Kindle books, with their inherent mobility and ease of availability, have freed readers from the constraints of physical books. Gone are the days of carrying bulky novels or meticulously searching for particular titles in shops. E-book devices, stylish and lightweight, effortlessly store an extensive library of books, allowing readers to immerse in their preferred reads whenever, everywhere. Whether traveling on a busy train, relaxing on a sun-kissed beach, or simply cozying up in bed, Kindle books provide an exceptional level of ease. A Reading World Unfolded: Exploring the Wide Array of Kindle Generac Generator Gp6500 Manual Generac Generator Gp6500 Manual The Kindle Store, a virtual treasure trove of bookish gems, boasts an wide collection of books spanning diverse genres, catering to every readers preference and preference. From gripping fiction and thought-provoking non-fiction to timeless classics and modern bestsellers, the E-book Store offers an unparalleled abundance of titles to discover. Whether seeking escape through immersive tales of fantasy and adventure, delving into the depths of historical narratives, or expanding ones understanding with insightful works of scientific and philosophy, the Kindle Store provides a gateway to a literary world brimming with limitless possibilities. A Revolutionary Force in the Literary Landscape: The Lasting Influence of Kindle Books Generac Generator Gp6500 Manual The advent of Kindle books has undoubtedly reshaped the literary scene, introducing a paradigm shift in the way books are published, disseminated, and consumed. Traditional publication houses have embraced the digital revolution, adapting their approaches to accommodate the growing demand for e-books. This has led to a rise in the accessibility of E-book titles, ensuring that readers have entry to a vast array of bookish works at their fingers. Moreover, Kindle books have democratized entry to literature, breaking down geographical limits and providing readers worldwide with equal opportunities to engage with the written word. Irrespective of their place or socioeconomic background, individuals can now immerse themselves in the intriguing world of literature, fostering a global community of readers. Conclusion: Embracing the Kindle Experience Generac Generator Gp6500 Manual E-book books Generac Generator Gp6500 Manual, with their inherent ease, versatility, and wide array of titles, have certainly transformed the way we encounter literature. They offer readers the liberty to explore the limitless realm of written expression, whenever, everywhere. As we continue to navigate the ever-evolving digital scene, E-book books stand as testament to the enduring power of storytelling, ensuring that the joy of reading remains accessible to all.

https://staging.conocer.cide.edu/public/Resources/HomePages/jeep_cj7_wiring_harness.pdf

Table of Contents Generac Generator Gp6500 Manual

1. Understanding the eBook Generac Generator Gp6500 Manual
 - The Rise of Digital Reading Generac Generator Gp6500 Manual
 - Advantages of eBooks Over Traditional Books
2. Identifying Generac Generator Gp6500 Manual
 - Exploring Different Genres
 - Considering Fiction vs. Non-Fiction
 - Determining Your Reading Goals
3. Choosing the Right eBook Platform
 - Popular eBook Platforms
 - Features to Look for in an Generac Generator Gp6500 Manual
 - User-Friendly Interface
4. Exploring eBook Recommendations from Generac Generator Gp6500 Manual
 - Personalized Recommendations
 - Generac Generator Gp6500 Manual User Reviews and Ratings
 - Generac Generator Gp6500 Manual and Bestseller Lists
5. Accessing Generac Generator Gp6500 Manual Free and Paid eBooks
 - Generac Generator Gp6500 Manual Public Domain eBooks
 - Generac Generator Gp6500 Manual eBook Subscription Services
 - Generac Generator Gp6500 Manual Budget-Friendly Options
6. Navigating Generac Generator Gp6500 Manual eBook Formats
 - ePub, PDF, MOBI, and More
 - Generac Generator Gp6500 Manual Compatibility with Devices
 - Generac Generator Gp6500 Manual Enhanced eBook Features
7. Enhancing Your Reading Experience
 - Adjustable Fonts and Text Sizes of Generac Generator Gp6500 Manual
 - Highlighting and Note-Taking Generac Generator Gp6500 Manual
 - Interactive Elements Generac Generator Gp6500 Manual
8. Staying Engaged with Generac Generator Gp6500 Manual

- Joining Online Reading Communities
 - Participating in Virtual Book Clubs
 - Following Authors and Publishers Generac Generator Gp6500 Manual
9. Balancing eBooks and Physical Books Generac Generator Gp6500 Manual
- Benefits of a Digital Library
 - Creating a Diverse Reading Collection Generac Generator Gp6500 Manual
10. Overcoming Reading Challenges
- Dealing with Digital Eye Strain
 - Minimizing Distractions
 - Managing Screen Time
11. Cultivating a Reading Routine Generac Generator Gp6500 Manual
- Setting Reading Goals Generac Generator Gp6500 Manual
 - Carving Out Dedicated Reading Time
12. Sourcing Reliable Information of Generac Generator Gp6500 Manual
- Fact-Checking eBook Content of Generac Generator Gp6500 Manual
 - Distinguishing Credible Sources
13. Promoting Lifelong Learning
- Utilizing eBooks for Skill Development
 - Exploring Educational eBooks
14. Embracing eBook Trends
- Integration of Multimedia Elements
 - Interactive and Gamified eBooks

Generac Generator Gp6500 Manual Introduction

Free PDF Books and Manuals for Download: Unlocking Knowledge at Your Fingertips In today's fast-paced digital age, obtaining valuable knowledge has become easier than ever. Thanks to the internet, a vast array of books and manuals are now available for free download in PDF format. Whether you are a student, professional, or simply an avid reader, this treasure trove of downloadable resources offers a wealth of information, conveniently accessible anytime, anywhere. The advent of online libraries and platforms dedicated to sharing knowledge has revolutionized the way we consume information. No longer confined to physical libraries or bookstores, readers can now access an extensive collection of digital books and

manuals with just a few clicks. These resources, available in PDF, Microsoft Word, and PowerPoint formats, cater to a wide range of interests, including literature, technology, science, history, and much more. One notable platform where you can explore and download free Generac Generator Gp6500 Manual PDF books and manuals is the internet's largest free library. Hosted online, this catalog compiles a vast assortment of documents, making it a veritable goldmine of knowledge. With its easy-to-use website interface and customizable PDF generator, this platform offers a user-friendly experience, allowing individuals to effortlessly navigate and access the information they seek. The availability of free PDF books and manuals on this platform demonstrates its commitment to democratizing education and empowering individuals with the tools needed to succeed in their chosen fields. It allows anyone, regardless of their background or financial limitations, to expand their horizons and gain insights from experts in various disciplines. One of the most significant advantages of downloading PDF books and manuals lies in their portability. Unlike physical copies, digital books can be stored and carried on a single device, such as a tablet or smartphone, saving valuable space and weight. This convenience makes it possible for readers to have their entire library at their fingertips, whether they are commuting, traveling, or simply enjoying a lazy afternoon at home. Additionally, digital files are easily searchable, enabling readers to locate specific information within seconds. With a few keystrokes, users can search for keywords, topics, or phrases, making research and finding relevant information a breeze. This efficiency saves time and effort, streamlining the learning process and allowing individuals to focus on extracting the information they need. Furthermore, the availability of free PDF books and manuals fosters a culture of continuous learning. By removing financial barriers, more people can access educational resources and pursue lifelong learning, contributing to personal growth and professional development. This democratization of knowledge promotes intellectual curiosity and empowers individuals to become lifelong learners, promoting progress and innovation in various fields. It is worth noting that while accessing free Generac Generator Gp6500 Manual PDF books and manuals is convenient and cost-effective, it is vital to respect copyright laws and intellectual property rights. Platforms offering free downloads often operate within legal boundaries, ensuring that the materials they provide are either in the public domain or authorized for distribution. By adhering to copyright laws, users can enjoy the benefits of free access to knowledge while supporting the authors and publishers who make these resources available. In conclusion, the availability of Generac Generator Gp6500 Manual free PDF books and manuals for download has revolutionized the way we access and consume knowledge. With just a few clicks, individuals can explore a vast collection of resources across different disciplines, all free of charge. This accessibility empowers individuals to become lifelong learners, contributing to personal growth, professional development, and the advancement of society as a whole. So why not unlock a world of knowledge today? Start exploring the vast sea of free PDF books and manuals waiting to be discovered right at your fingertips.

FAQs About Generac Generator Gp6500 Manual Books

1. Where can I buy Generac Generator Gp6500 Manual books? Bookstores: Physical bookstores like Barnes & Noble, Waterstones, and independent local stores. Online Retailers: Amazon, Book Depository, and various online bookstores offer a wide range of books in physical and digital formats.
2. What are the different book formats available? Hardcover: Sturdy and durable, usually more expensive. Paperback: Cheaper, lighter, and more portable than hardcovers. E-books: Digital books available for e-readers like Kindle or software like Apple Books, Kindle, and Google Play Books.
3. How do I choose a Generac Generator Gp6500 Manual book to read? Genres: Consider the genre you enjoy (fiction, non-fiction, mystery, sci-fi, etc.). Recommendations: Ask friends, join book clubs, or explore online reviews and recommendations. Author: If you like a particular author, you might enjoy more of their work.
4. How do I take care of Generac Generator Gp6500 Manual books? Storage: Keep them away from direct sunlight and in a dry environment. Handling: Avoid folding pages, use bookmarks, and handle them with clean hands. Cleaning: Gently dust the covers and pages occasionally.
5. Can I borrow books without buying them? Public Libraries: Local libraries offer a wide range of books for borrowing. Book Swaps: Community book exchanges or online platforms where people exchange books.
6. How can I track my reading progress or manage my book collection? Book Tracking Apps: Goodreads, LibraryThing, and Book Catalogue are popular apps for tracking your reading progress and managing book collections. Spreadsheets: You can create your own spreadsheet to track books read, ratings, and other details.
7. What are Generac Generator Gp6500 Manual audiobooks, and where can I find them? Audiobooks: Audio recordings of books, perfect for listening while commuting or multitasking. Platforms: Audible, LibriVox, and Google Play Books offer a wide selection of audiobooks.
8. How do I support authors or the book industry? Buy Books: Purchase books from authors or independent bookstores. Reviews: Leave reviews on platforms like Goodreads or Amazon. Promotion: Share your favorite books on social media or recommend them to friends.
9. Are there book clubs or reading communities I can join? Local Clubs: Check for local book clubs in libraries or community centers. Online Communities: Platforms like Goodreads have virtual book clubs and discussion groups.
10. Can I read Generac Generator Gp6500 Manual books for free? Public Domain Books: Many classic books are available for free as they're in the public domain. Free E-books: Some websites offer free e-books legally, like Project Gutenberg or Open Library.

Find Generac Generator Gp6500 Manual :

[jeep cj7 wiring harness](#)

[jeep cherokee 1998 owner manual](#)

[jeep cherokee 1999 service and repair manual](#)

je vous eacuteecris du vel dhiv

[jeep grand cherokee workshop manual 2015](#)

je suis plus que vainqueur je sais qui je suis

~~jcb loadall 530 533 535 540 telescopic handler service repair manual~~

jeep cherokee xj 1997 1999 2001 service repair manual srm

jd 410 c owner manual

jeep cherokee xj 1998 repair service manual

je teacuteecris de la trancheacutee correspondance de guerre

jeacutesus lheacuteritier histoire dun meacutetissage culturel hors collection

[jd disc mower 925 manual](#)

~~jd 200lc repair manual~~

jee answer key paper for version h

Generac Generator Gp6500 Manual :

universität düsseldorf psychologie - May 19 2022

web das institut für experimentelle psychologie ist eine wissenschaftliche einrichtung in der mathematisch naturwissenschaftlichen fakultät der heinrich heine universität düsseldorf verantwortlichkeit

psychologie der höchstleistung dem geheimnis des erfolges auf der - Jul 01 2023

web in diesem buch wird der frage nachgegangen wie höchstleistungen zustande kommen die analysen beziehen sich dabei nicht nur auf sportliche spitzenleistungen auch in der kunst musik und in

[psychologie der hochstleistung dem geheimnis des michael p](#) - Aug 22 2022

web as this psychologie der hochstleistung dem geheimnis des it ends in the works bodily one of the favored books

psychologie der hochstleistung dem geheimnis des collections that we have this is why you remain in the best website to see the amazing ebook to have the game of power marion knaths 2021 07 29

psychologie der hochstleistung dem geheimnis des book - Dec 26 2022

web psychologie der hochleistung dem geheimnis des das geheimnis der bethmännchen und andere frankfurter merkwürdigkeiten aug 03 2021 deutsche nationalbibliografie may 12 2022 blut die geheimnisse unseres flüssigen organs sep 16 2022 gesundheit oder krankheit wir haben die antwort im blut ich zeige

psychologie der hochleistung dem geheimnis des book - Feb 25 2023

web der leitung als regelung der persönlichen verhältnisse zwischen arbeitgeber und arbeitnehmer sein buch zur rationalisierung fokussiert auf die reorganisation von unternehmen des verarbeitenden gewerbes lohnpolitik sowie zahlreiche aspekten der umsetzung seiner grundsätze die technische mechanik des maschineningenieurs mit

psychologie der hochleistung dem geheimnis des uniport edu - Mar 17 2022

web apr 12 2023 psychologie der hochleistung dem geheimnis des 1 8 downloaded from uniport edu ng on april 12 2023 by guest psychologie der hochleistung dem geheimnis des as recognized adventure as competently as experience not quite lesson amusement as capably as bargain can be gotten by just checking out a ebook

studienstruktur fakultät psychologie tu dresden - Feb 13 2022

web mar 24 2022 der studiengang hpsts sei interdisziplinär ausgerichtet und nehme bezug auf aktuelle psychologische themen so heißt es oftmals wenn man nach informationen über diesen studiengang sucht daher habe ich mich entschieden meinen master an der tu dresden zu absolvieren und wurde dahingehend nicht enttäuscht

psychologie der hochleistung dem geheimnis des pdf - Sep 22 2022

web jul 18 2023 psychologie der hochleistung dem geheimnis des 2 8 downloaded from uniport edu ng on july 18 2023 by guest versuchen hirnforscher verhaltenspsychologen und soziologen gemeinsam neue antworten auf eine uralte frage zu finden warum tun wir eigentlich was wir tun was genau prägt unsere gewohnheiten

psychologie der höchstleistung dem geheimnis des erfolges auf der - Sep 03 2023

web michael draksal psychologie der höchstleistung dem geheimnis des erfolges auf der spur leistungssport wissenschaft musik kunst wirtschaft taschenbuch 1 oktober 2005 von michael draksal autor 2 sternbewertungen alle formate und editionen anzeigen kindle 15 99 lies mit kostenfreien app taschenbuch 15 21 1 gebraucht ab

psychologie der hochleistung dem geheimnis des 2022 - Jul 21 2022

web mentale modelle 30 denkwerkzeuge die den durchschnitt vom außergewöhnlichen unterscheiden verbesserte entscheidungsfindung logische analyse und problemlösung

psychologie der hochleistung dem geheimnis des 2013 - Oct 04 2023

web psychologie der hochleistung dem geheimnis des downloaded from 2013 thecontemporaryaustin org by guest nathen burgess sportpsychologie macmillan sie halten die weltweit größte sammlung moderner mentaltechniken in den händen ob prüfung wettkampf unternehmensführung oder alltag zu jedem bereich gibt es

psychologie der hochleistung dem geheimnis des - May 31 2023

web psychologie der hochleistung dem geheimnis des 3 3 buch zielt darauf sowohl aus wissenschaftlicher wie aus praktischer sicht konkrete handlungsfelder des spitzensports und des spitzenmanagements abzugrenzen und detailliert zu untersuchen um greifbare hinweise auf den ursprung und die konstanz von spitzenleistungen zu gewinnen dabei

psychologie der höchleistung by michael draksal overdrive - Jan 27 2023

web sep 2 2013 in diesem buch wird der frage nachgegangen wie höchleistungen zustande kommen die analysen beziehen sich dabei nicht nur auf sportliche spitzenleistungen auch in der kunst musik und in der wirtschaft leisten einige menschen viel mehr als andere woran liegt das

psychologie der hochleistung dem geheimnis des pdf - Oct 24 2022

web jun 18 2023 this one merely said the psychologie der hochleistung dem geheimnis des pdf is universally compatible bearing in mind any devices to read reinventing prosperity graeme maxton 2016 10 08 an important contribution to the global debate about growth equality climate change and the path to a viable human future

psychologie der hochleistung dem geheimnis des wrbb neu - Nov 24 2022

web psychologie der hochleistung dem geheimnis des 1 psychologie der hochleistung dem geheimnis des this is likewise one of the factors by obtaining the soft documents of this psychologie der hochleistung dem geheimnis des by online you might not require more period to spend to go to the book establishment as well as

psychologie der höchleistung von michael draksal scribd - Apr 29 2023

web in diesem buch wird der frage nachgegangen wie höchleistungen zustande kommen die analysen beziehen sich dabei nicht nur auf sportliche spitzenleistungen auch in der kunst musik und in der wirtschaft leisten einige menschen viel mehr als andere

psychologie der hochleistung dem geheimnis des pdf - Jun 19 2022

web may 20 2023 psychologie der hochleistung dem geheimnis des but end up in harmful downloads rather than reading a good book with a cup of coffee in the afternoon instead they are facing with some infectious virus inside their computer psychologie der hochleistung dem geheimnis des is available in our book

psychologie der höchleistung dem geheimnis des erfolges auf der - Aug 02 2023

web june 1st 2020 psychologie der hochleistung dem geheimnis des erfolges auf der spur leistungssport wissenschaft musik kunst wirtschaft psychologie der immobilienvermarktung die wichtigsten erkenntnisse aus nlp gehirnforschung kommunikation verkaufs und werbepsychologie

psychologie der höchleistung dem geheimnis des erfolges auf der - Mar 29 2023

web psychologie der höchleistung dem geheimnis des erfolges auf der spur leistungssport wissenschaft musik kunst

wirtschaft ebook draksal michael amazon de kindle shop

universität düsseldorf psychologie hhu - Apr 17 2022

web preis der gesellschaft von freunden und förderern der heinrich heine universität düsseldorf preis der goethe

buchhandlung preis für die beste dissertation des jahres reinhard heyne und emmi heyne preis walter clawiter preis

externe wissenschaftspreise horizon an der hhu eine auswahl nächste ebene öffnen

ifa divination system - Feb 08 2023

web aug 18 2016 1 after 30 years of study i have come to the conclusion that odu ifa is a coded reference to ritual magic

theology and science the way these three subjects are

african traditional religions textbook ifa robert w - Mar 09 2023

web we have the pleasure to announce a course in the odù of ifá by use of electronic means the course is separated into four

modules each covering four mejis and their omo odú

ifa divination tools upon ifa iyerosun powder iroke ifa opele - Apr 29 2022

web jan 1 2021 the teaching will cover each odu ifa the story associate with each odu ese ifa the orisa that reincarnate and associate

ianifa ifa priestess women in ifa yoruba religion - Oct 04 2022

web 16 major odu ifa the knowledge and secrets of each odu ifa and the creation and history of each of the sixteen major

odus which are called oju odu is very sacred the history

[an exploration of odu ifa book oyeku ofun temple](#) - Jan 07 2023

web may 9 2023 upon ifa divination tray and ikin sacred palm nuts these are two of the most important resources for ifa divination the holy odu 256 parables

16 truths of ifa oyeku ofun temple - Dec 06 2022

web dec 4 2013 odu ifa ogbe obara says this we knelt down and chose our destinies on getting to earth we are in too much of a hurry destiny cannot be re chosen unless we

secrets of the odu of ifa c osamaro ibie 2023 - Nov 24 2021

web jun 12 2023 com odù ifá learn how to interpret ifa religion nigeria secrets of the odus of ifa ifa bible google books an exploration of odu ifa book oyeku ofun

16 truths of ifa linkedin - Jul 01 2022

web jul 6 2019 odu ifa what is odu ifa ifa provides its wisdom and messages to mankind through an oral corpus known as odu ifa there isn't one source or book that contains

[ifa oracle the 16 odu ifa their meaning afrikaiswoke.com](#) - Nov 05 2022

web dec 16 2022 when the 16 odu ifa are combined a total of 256 odu emerges which is essentially a collection of 16 odu each of which has sixteen alternatives that are
secrets of the odu of ifa secure4 khronos - Oct 24 2021

course in the secrets of odù ifá aye akamara - May 11 2023

web secrets of the odu of ifa jaap verduijn s odu ifa collection volume 01 aug 07 2022 the main odu ika and its fifteen sub odu s this fully illustrated odu book is the first in a

the hidden mysteries of odu ifa medium - Apr 10 2023

web secrets of the odu of ifa below the secret history of dreaming robert moss 2010 09 07 dreaming is vital to the human story it is essential to our survival and evolution to

secrets of the odu of ifa 2023 cyberlab sutd edu sg - Jul 13 2023

an integral part of the odu ifá interpretation is the process of consulting with ifá and the oral scriptures using the ifá divination system it is the most see more

ifa religion what is ifa the odu and their meaning oshaeifa com - Aug 02 2022

web jun 26 2014 16 truths of ifa by fagbemijo amosun fakayode otun amufawuni of ibadan land oyeku ofun temple 1 this is a benevolent universe on this odu ifa

secrets of the odu of ifa secure4 khronos - Dec 26 2021

web secrets of the odu of ifa getting the books secrets of the odu of ifa now is not type of inspiring means you could not isolated going in the manner of books accrual or library or

ifa federal how to memories the seniority 16 odus how to - Jan 27 2022

web of ifa it is wholly straightforward then presently we extend the associate to buy and create bargains to retrieve and deploy secrets of the odu of ifa therefore

secrets of the odu of ifa - Sep 03 2022

web learn all about the ifa odu what are they what do they mean what is ifa treaty of the 256 oddun and more oshaeifa com
odu ifa farinade olokun - Feb 25 2022

web ogbe is greeted saaki odu a royal greeting while ofun is greeted yeeparipa odu which i consider as solemn the odus are 16 in number and they were the first disciples of

odu ifa corpus learn about the 16 odu ifa and - Aug 14 2023

ifá is an ancient religion and a complex system of divination conceptualized many centuries ago by the yoruba people of west africa ifá yoruba religion is based on oral literature scriptures known as odu ifá or the ifa corpus it is a collection of ifá

spiritualtraditions timeless wisdom cultural and historical see more

[secrets of the odu of ifa philip j neimark copy](#) - Jun 12 2023

the sacred oral scriptures of odu ifá corpus are structured into a total of 256 signs these 256 signs are derived from the 16 major odu ifá or 16 principle signs of ifá in other words see more

ifa religion beliefs learn about the concepts of ifa spirituality - May 31 2022

web jul 29 2019 odu ifa or oddun is a collection of 16 major odu ifa oju odu signs and 240 minor odu ifa signs that result in a total of 256 odu ifa signs containing the wisdom and

[learn secrets of odu ifa with yoruba teacher africa speaks com](#) - Mar 29 2022

web the 256 odu signatures of ifa and the thousands of ese verses they contain comprise all of the science cosmology metaphysics medicine and wisdom held within that sacred

oxford practice grammar basic with answers coe norman - Sep 20 2022

web oxford practice grammar advanced with answers george yule oxford university press 2006 foreign language study 280 pages this new three level series edition

oxford practice grammar advanced with answers - May 17 2022

web mar 30 2022 october 14 2016 created by mek added new book oxford practice grammar with answers by george yule 2009 oxford university press usa edition

[oxford practice grammar with answers advanced google](#) - Feb 11 2022

oxford practice grammar basic with answers google books - Mar 27 2023

web jul 28 2020 refreshed with a new design oxford practice grammar is a three level english grammar practice series for the classroom or self study its tried and trusted

[oxford practice grammar basic with answers google books](#) - Nov 22 2022

web mar 25 1999 provides clear explanations of english grammar with exercises on the facing page which provide practice in form and use this edition includes additional grammar

[oxford practice grammar with answers intermediate](#) - Jan 25 2023

web ix 439 pages 27 cm this book provides grammar structures that are explained in context so you understand how they work in practice practice activities that check that

[tests oxford practice grammar oxford university press](#) - Apr 27 2023

web oxford practice grammar advanced tests download the tests and answer key for oxford practice grammar advanced tests pdf 520kb tests answer key pdf

[oxford practice grammar with answers open library](#) - Mar 15 2022

[english grammar level test oxford online english](#) - Sep 01 2023

web about the grammar test there are 40 questions in this grammar test they cover all levels from elementary a1 to advanced c1 in a random order some of the questions

[practice exercises oxford practice grammar oxford university](#) - Jun 29 2023

web practice exercises read and write tests choose practice exercise 01 practice exercise 02 practice exercise 03 practice exercise 04 practice exercise 05 practice

[oxford practice grammar advanced with answers google books](#) - Jul 19 2022

web this book provides detailed explanations covering english grammar rules in depth that takes your grammar knowledge to a much higher level practice activities to stretch

oxford practice grammar advanced with answers google books - Jun 17 2022

web refreshed with a new design oxford practice grammar is a three level english grammar practice series for the classroom or self study its tried and trusted methodology

oxford practice grammar basic with answers language advisor - Apr 15 2022

web advanced george yule google books oxford practice grammar with answers advanced this book provides detailed explanations covering english grammar rules in

advanced oxford practice grammar oxford university press - May 29 2023

web 14 hours ago oxford practice grammar advanced resources select a resource to use practice exercises read and write tests

[oxford practice grammar with answers by various goodreads](#) - Oct 22 2022

web oxford practice grammar basic with answers by coe norman publication date 2006 topics english language textbooks for foreign speakers english language

[tests oxford practice grammar oxford university press](#) - Jul 31 2023

web oxford practice grammar basic tests download the tests and answer key for oxford practice grammar basic tests pdf 520kb tests answer key pdf 120kb

oxford practice grammar with answers amazon com - Feb 23 2023

web jan 1 1999 there is a newer edition of this item oxford practice grammar intermediate with key practice boost cd rom pack 7 17 254 in stock oxford practice

oxford practice grammar learning resources oxford - Oct 02 2023

web 2 days ago learning resources bank grammar and vocabulary oxford practice grammar take a test listen to dialogues and practise your english with oxford

oxford practice grammar intermediate with answers - Aug 20 2022

web jul 28 2020 oxford practice grammar advanced with answers norman coe mark harrison oxford university press jul 28 2020 foreign language study 264 pages

pdf oxford practice grammar with answers - Dec 24 2022

web oxford practice grammar basic with answers oxford practice grammar norman coe mark harrison ken paterson oxford university press 2006 english language