

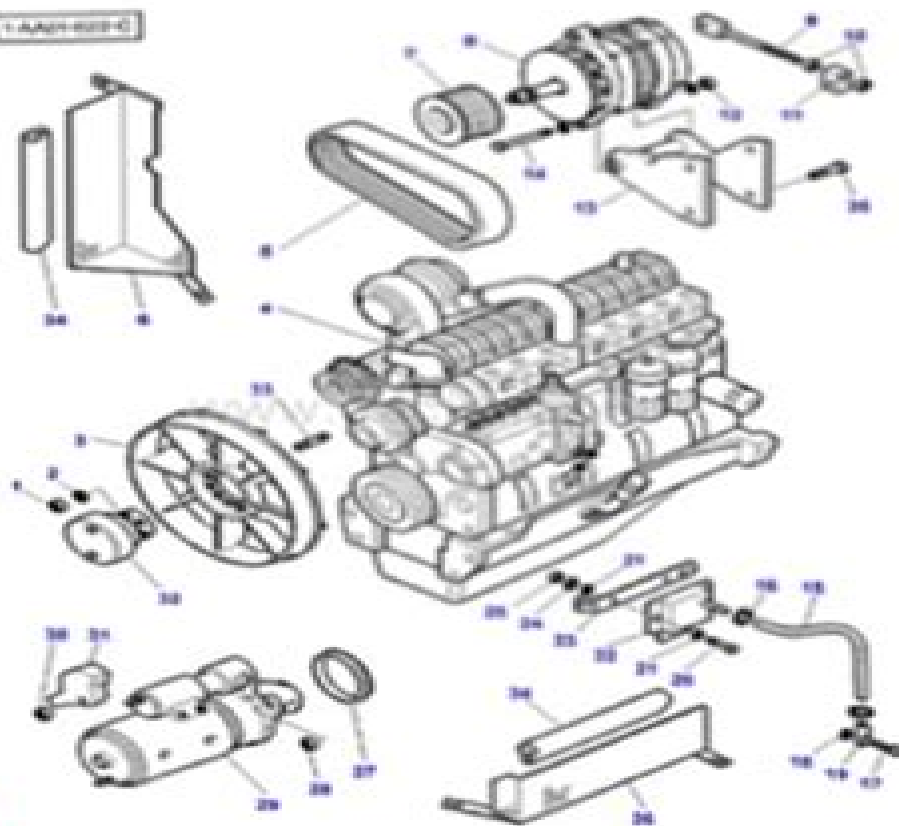

JOHN DEERE

TEHNICAL MANUAL

1.44410004



863 pag.

Manual For A John Deere 2140

Annelies Wilder-Smith



Manual For A John Deere 2140:

As recognized, adventure as well as experience nearly lesson, amusement, as competently as conformity can be gotten by just checking out a ebook **Manual For A John Deere 2140** with it is not directly done, you could say yes even more in this area this life, roughly speaking the world.

We meet the expense of you this proper as without difficulty as simple pretension to acquire those all. We come up with the money for Manual For A John Deere 2140 and numerous books collections from fictions to scientific research in any way. accompanied by them is this Manual For A John Deere 2140 that can be your partner.

<https://staging.conocer.cide.edu/About/detail/fetch.php/les%20enqueircrtes%20de%20inspecteur%20higgins%20tome%20qui%20a%20tueacute%20laastrologue.pdf>

Table of Contents Manual For A John Deere 2140

1. Understanding the eBook Manual For A John Deere 2140
 - The Rise of Digital Reading Manual For A John Deere 2140
 - Advantages of eBooks Over Traditional Books
2. Identifying Manual For A John Deere 2140
 - Exploring Different Genres
 - Considering Fiction vs. Non-Fiction
 - Determining Your Reading Goals
3. Choosing the Right eBook Platform
 - Popular eBook Platforms
 - Features to Look for in an Manual For A John Deere 2140
 - User-Friendly Interface
4. Exploring eBook Recommendations from Manual For A John Deere 2140
 - Personalized Recommendations
 - Manual For A John Deere 2140 User Reviews and Ratings
 - Manual For A John Deere 2140 and Bestseller Lists

-
5. Accessing Manual For A John Deere 2140 Free and Paid eBooks
 - Manual For A John Deere 2140 Public Domain eBooks
 - Manual For A John Deere 2140 eBook Subscription Services
 - Manual For A John Deere 2140 Budget-Friendly Options
 6. Navigating Manual For A John Deere 2140 eBook Formats
 - ePub, PDF, MOBI, and More
 - Manual For A John Deere 2140 Compatibility with Devices
 - Manual For A John Deere 2140 Enhanced eBook Features
 7. Enhancing Your Reading Experience
 - Adjustable Fonts and Text Sizes of Manual For A John Deere 2140
 - Highlighting and Note-Taking Manual For A John Deere 2140
 - Interactive Elements Manual For A John Deere 2140
 8. Staying Engaged with Manual For A John Deere 2140
 - Joining Online Reading Communities
 - Participating in Virtual Book Clubs
 - Following Authors and Publishers Manual For A John Deere 2140
 9. Balancing eBooks and Physical Books Manual For A John Deere 2140
 - Benefits of a Digital Library
 - Creating a Diverse Reading Collection Manual For A John Deere 2140
 10. Overcoming Reading Challenges
 - Dealing with Digital Eye Strain
 - Minimizing Distractions
 - Managing Screen Time
 11. Cultivating a Reading Routine Manual For A John Deere 2140
 - Setting Reading Goals Manual For A John Deere 2140
 - Carving Out Dedicated Reading Time
 12. Sourcing Reliable Information of Manual For A John Deere 2140
 - Fact-Checking eBook Content of Manual For A John Deere 2140
 - Distinguishing Credible Sources
 13. Promoting Lifelong Learning

- Utilizing eBooks for Skill Development
 - Exploring Educational eBooks
14. Embracing eBook Trends
- Integration of Multimedia Elements
 - Interactive and Gamified eBooks

Manual For A John Deere 2140 Introduction

In today's digital age, the availability of Manual For A John Deere 2140 books and manuals for download has revolutionized the way we access information. Gone are the days of physically flipping through pages and carrying heavy textbooks or manuals. With just a few clicks, we can now access a wealth of knowledge from the comfort of our own homes or on the go. This article will explore the advantages of Manual For A John Deere 2140 books and manuals for download, along with some popular platforms that offer these resources. One of the significant advantages of Manual For A John Deere 2140 books and manuals for download is the cost-saving aspect. Traditional books and manuals can be costly, especially if you need to purchase several of them for educational or professional purposes. By accessing Manual For A John Deere 2140 versions, you eliminate the need to spend money on physical copies. This not only saves you money but also reduces the environmental impact associated with book production and transportation. Furthermore, Manual For A John Deere 2140 books and manuals for download are incredibly convenient. With just a computer or smartphone and an internet connection, you can access a vast library of resources on any subject imaginable. Whether you're a student looking for textbooks, a professional seeking industry-specific manuals, or someone interested in self-improvement, these digital resources provide an efficient and accessible means of acquiring knowledge. Moreover, PDF books and manuals offer a range of benefits compared to other digital formats. PDF files are designed to retain their formatting regardless of the device used to open them. This ensures that the content appears exactly as intended by the author, with no loss of formatting or missing graphics. Additionally, PDF files can be easily annotated, bookmarked, and searched for specific terms, making them highly practical for studying or referencing. When it comes to accessing Manual For A John Deere 2140 books and manuals, several platforms offer an extensive collection of resources. One such platform is Project Gutenberg, a nonprofit organization that provides over 60,000 free eBooks. These books are primarily in the public domain, meaning they can be freely distributed and downloaded. Project Gutenberg offers a wide range of classic literature, making it an excellent resource for literature enthusiasts. Another popular platform for Manual For A John Deere 2140 books and manuals is Open Library. Open Library is an initiative of the Internet Archive, a non-profit organization dedicated to digitizing cultural artifacts and making them accessible to the public. Open Library hosts millions of books, including both public domain works and contemporary titles. It also allows users to

borrow digital copies of certain books for a limited period, similar to a library lending system. Additionally, many universities and educational institutions have their own digital libraries that provide free access to PDF books and manuals. These libraries often offer academic texts, research papers, and technical manuals, making them invaluable resources for students and researchers. Some notable examples include MIT OpenCourseWare, which offers free access to course materials from the Massachusetts Institute of Technology, and the Digital Public Library of America, which provides a vast collection of digitized books and historical documents. In conclusion, Manual For A John Deere 2140 books and manuals for download have transformed the way we access information. They provide a cost-effective and convenient means of acquiring knowledge, offering the ability to access a vast library of resources at our fingertips. With platforms like Project Gutenberg, Open Library, and various digital libraries offered by educational institutions, we have access to an ever-expanding collection of books and manuals. Whether for educational, professional, or personal purposes, these digital resources serve as valuable tools for continuous learning and self-improvement. So why not take advantage of the vast world of Manual For A John Deere 2140 books and manuals for download and embark on your journey of knowledge?

FAQs About Manual For A John Deere 2140 Books

How do I know which eBook platform is the best for me? Finding the best eBook platform depends on your reading preferences and device compatibility. Research different platforms, read user reviews, and explore their features before making a choice. Are free eBooks of good quality? Yes, many reputable platforms offer high-quality free eBooks, including classics and public domain works. However, make sure to verify the source to ensure the eBook credibility. Can I read eBooks without an eReader? Absolutely! Most eBook platforms offer web-based readers or mobile apps that allow you to read eBooks on your computer, tablet, or smartphone. How do I avoid digital eye strain while reading eBooks? To prevent digital eye strain, take regular breaks, adjust the font size and background color, and ensure proper lighting while reading eBooks. What the advantage of interactive eBooks? Interactive eBooks incorporate multimedia elements, quizzes, and activities, enhancing the reader engagement and providing a more immersive learning experience. Manual For A John Deere 2140 is one of the best book in our library for free trial. We provide copy of Manual For A John Deere 2140 in digital format, so the resources that you find are reliable. There are also many Ebooks of related with Manual For A John Deere 2140. Where to download Manual For A John Deere 2140 online for free? Are you looking for Manual For A John Deere 2140 PDF? This is definitely going to save you time and cash in something you should think about.

Find Manual For A John Deere 2140 :

les enquecirtces de linspecteur higgins tome qui a tueacute lastrologue

les fregraveres kip

les services secrets chinois de mao agrave nos jours

les miscellaneacutees du rock

les procegraves de jeanne dare

les morts mysteacuterieuses de lhhistoire vol charlemagne et hugues capet

les folies de la duchesse dabrantegraves litteacuterature franccedilaise

les jours les mois les aneacutees

les plus beaux romans damour

les marionnettes de lombre la saga de lombre t

les strateacutegies fatales figures

les grandes heures de solesmes

les piliers de la sagesse

les lettres et petits mots du idien

les sorties de deacutelinquance

Manual For A John Deere 2140 :

download detailed lkg syllabus byju s - Sep 08 2023

web get detailed lkg syllabus cbse lkg stand for lower kindergarten which is a preschool education in this class students are taught by playing singing and through practical activities such as drawing they learn bits and pieces of the alphabet and numbers

2021 lgs kilavuzu yayimlandi meb - Jul 26 2022

web 2020 2021 eğitim öğretim yılı sonunda sınavla öğrenci alacak ortaöğretim kurumlarına ilişkin merkezî sınav başvuru ve uygulama kılavuzu meb gov tr internet adresinden açıklandı kılavuzda listesi ve kontenjanları verilen merkezî sınavla öğrenci alacak fen liseleri sosyal bilimler liseleri mesleki ve teknik anadolu liselerinin anadolu teknik

İstanbul liseleri lgs taban puanları 2023 2024 - Feb 18 2022

web lise 2023 puan 2022 puan 2023 kontenjan 2022 kontenjan 2023 minimum yüzdeler dilim 2022 minimum yüzdeler dilim

ilçe alan türü Öğrenim dili 1 galatasaray Üniversitesi galatasaray lisesi

cbse lkg syllabus for all subjects 2023 24 updated - May 04 2023

web may 2 2023 the lkg class syllabus includes all the subjects that children need for their physical and mental development although parents are advised to once check the latest syllabus in the school to which their children are admitted let s move toward the lkg class subject and lkg class syllabus for 2023 24

complete lkg syllabus guide for 2023 2024 download pdf - Jul 06 2023

web contact us lkg syllabus teaches values social skills numbers alphabets fruits vegetables etc lkg syllabus promotes child development learn more here

cbse lkg syllabus english maths evs hindi syllabus - Feb 01 2023

web oct 2 2023 here we discuss detailed syllabus of lkg class which may be different from school to school and their followed education board lkg english syllabus english syllabus for class lkg formulated by cbse is as follows lkg maths syllabus maths syllabus for class lkg formulated by cbse is as follows lkg environmental science

cbse lkg syllabus for all subjects 2022 23 earning careers - Dec 31 2022

web jul 25 2022 here lkg class cbse syllabus is given for all subjects table of content subjects of lkg syllabus cbse lkg english syllabus mathematics lkg syllabus for cbse lkg syllabus for environmental science cbse lkg syllabus for general awareness lkg hindi syllabus for cbse cbse lkg syllabus 2022 23

cbse lkg syllabus vedantu - Mar 02 2023

web nov 7 2023 the detailed segmentation of the lkg syllabus cbse pdf here will highlight the learning process directed by the education board following such methods will help develop various academic cognitive and interpersonal skills among children let us take a quick look at the lkg syllabus here

2022 lgs kapsamındaki merkezî sınav kılavuzu - Sep 27 2022

web mar 29 2022 t c millî eğitim bakanlığı millî eğitim bakanı mahmut Özer lgs kılavuzuna ilişkin yaptığı açıklamada şu bilgileri paylaştı lgs kapsamında 5 haziran 2022 de uygulanacak merkezî sınavın başvuruları 4 14 nisan 2022 de bakanlık tarafından merkezî olarak gerçekleştirilecek

english class online online class lkg matriculation english - Apr 03 2023

web online class lkg matriculation english alphabets lkg english full course 2021 22 lkg syllabus lkg online classes ikg class english alphabet

istanbul school of foreign languages syllabus - Nov 29 2022

web the aims of this syllabus are to enable learners to develop the language and skills needed for effective sophisticated communication in english and to provide them with an opportunity to three quizzes one in class and two take home online 100 marks each one in class progress test at the end of the track 100 marks 30 integrated skills

class lkg matriculation syllabus sam arabtravelers com - Apr 22 2022

web class lkg matriculation syllabus 1 class lkg matriculation syllabus essentials of english grammar composition a y 2023 24 onward education world ananda vikatan annual planner mental maths An anta vikaṭan topi shukla living and nonliving interview questions and answers home schooling a pathway to success publisher s monthly

lkg syllabus 2024 english environmental science maths - Oct 09 2023

web sep 20 2023 lkg syllabus 2024 check the latest syllabus for lkg english environmental science general awareness maths at embibe study material ncert books solutions

class lkg matriculation syllabus pdf esa pybossa com - May 24 2022

web class lkg matriculation syllabus pdf pages 2 4 class lkg matriculation syllabus pdf upload jason l hayda 2 4 downloaded from esa pybossa com on september 28 2023 by jason l hayda of the outstanding literature legacy that o henry left behind there is an american annual award after his name given to exceptional short stories

class lkg matriculation syllabus rhur impacthub net - Aug 27 2022

web class lkg matriculation syllabus sboa matriculation and higher secondary school chennai narayana e techno school arumbakkam schoolconnects difference between cbse and state board syllabus everything that you wanted to know about cbse icse igcse admission maharishi vidya mandir school selection between ashram vidya

lkg syllabus for cbse and icse 2023 download pdf - Aug 07 2023

web jul 3 2023 we have updated this page with syllabus for lkg in 2023 as per the latest curriculum there s 4 subjects to be taught in lower kg they are english maths general awareness and environmental science evs view or download the subject wise syllabus here lkg english syllabus lkg maths syllabus lkg evs general awareness

class lkg matriculation syllabus rhur impacthub net - Mar 22 2022

web sep 11 2023 class lkg matriculation syllabus constitution summary article 371 domicile requirement selection between ashram vidya mandir mylapore and pss admission maharishi vidya mandir school narayana e techno school arumbakkam schoolconnects difference between cbse and state board syllabus sboa

class lkg matriculation syllabus vps huratips com - Jun 24 2022

web 2 class lkg matriculation syllabus 2021 12 25 language a delight aim of the picture dictionary to improve children s understanding of english to help children develop their dictionary skills to encourage children to enjoy learning englishspecifically designed to engage and motivate young learners and to make english a fun its special

matriculation mathematics semester 1 notes 2022 - Oct 29 2022

web ics computer part 1 ch 1 information technology ics fsc part 1 lkg latest syllabus lkg syllabus 2020 2021 junior kg syllabus pp1 syllabus 2020 2021 how to download bsc maths solution notes books 1st 2nd 3rd year b sc mathematics tech

hindi kutam bca maths

lkg syllabus 2023 24 check here for all subjects syllabus - Jun 05 2023

web jul 4 2023 subject wise lkg syllabus 2023 24 the complete lkg syllabus 2023 of mathematics english environment science and general knowledge for class lkg is given below cbse lkg syllabus 2023 for mathematics check out the syllabus for mathematics prescribed by cbse for class lkg

55 guide answers fred and theresa holtzclaw copy - Dec 12 2021

web we couldn't find anything for teresa holtzclaw looking for people or posts try entering a name location or different words

chapter 6 a tour of the cell east tennessee state university - Jun 29 2023

web 1 the study of cells has been limited by their small size and so they were not seen and described until 1665 when robert hooke first looked at dead cells from an oak tree his contemporary anton van leeuwenhoek crafted lenses and with the improvements in optical aids a new world was opened

ap biology reading guide fred and theresa holtzclaw answer key - May 17 2022

web biology guide answers fred and theresa holtzclaw downloaded from ams istanbul edu tr by guest amiya rowe chapter 10 photosynthesis biology e portfolio textbook or revision guide which is better to study

chapter 8 an introduction to metabolism east tennessee state - Mar 27 2023

web fred and theresa holtzclaw chapter 12 cell cycle 1 what are the three key functions of cell division 2 what is meant by cell cycle the cell cycle is the life of a cell from the time it is first formed from a dividing parent cell until its own division into two daughter cells

ap biology reading guide fred and theresa holtzclaw chapter 5 - Oct 22 2022

web ap biology reading guide fred and theresa holtzclaw chapter 54 answers ap biology reading guide fred and theresa holtzclaw chapter 55 ap biology study guide online activities chapter 16 ap biology test answers for chapter 10 ap chem lab 4 analysis of alum ap chem lab report determine the empirical formula of silver oxide ap chemistry

ap biology reading guide fred and theresa holtzclaw chapter 54 - Jun 17 2022

web jun 21 2019 fred and theresa holtzclaw answer guide github gist instantly share code notes and snippets

ch 21 genomes and their evolution fred and - May 29 2023

web ap biology reading guide julia keller 12d fred and theresa holtzclaw chapter 6 tour of the cell 5 which two domains consist of prokaryotic cells organisms of the domains bacteria and archaea consist of prokaryotic cells protists fungi animals and plants all consist of eukaryotic cells 6

chapter 6 tour of the cell biology e portfolio - Apr 27 2023

web 1 define metabolism 2 there are two types of reactions in metabolic pathways anabolic and catabolic a which reactions release energy b which reactions consume energy c which reactions build up larger molecules d which reactions break down molecules e which reactions are considered uphill f what type of reaction is photosynthesis

biology guide answers fred and theresa holtzclaw - Mar 15 2022

web reading guide flashcards and study sets campbell 8th edition reading guides fred and theresa holtzclaw campbell biology 8th edition chapter 1 introduction chapter 20 biotechnology chapter 38 angiosperms chapter 2 biochemistry chapter 21 genomes chapter 39 plant responses chapter 3

ch 5 the structure and function of large biological - Nov 22 2022

web the enigmatic realm of ap reading guide fred and theresa holtzclaw answers chapter 7 unleashing the language is inner magic in a fast paced digital era where connections and knowledge intertwine the enigmatic realm of

chapter 5 structure and function of large biological molecules - Jul 31 2023

web 1 the large molecules of all living things fall into four main classes unlike lipids carbohydrates proteins and nucleic acids are macromolecular chain like molecules called polymers 2 define macromolecule macromolecules are characterized by their relatively great size on the molecular scale 3 what are polymers and monomers

leology welcome - Jan 25 2023

web 1 in the overview figure 1 3 recalls many of the properties of life label the seven properties illustrated here and give a different example of each concept 1 1 themes connect the concepts of biology 2 what are emergent properties give two examples 3 life is organized on many scales

chapter 12 cell cycle biology e portfolio - Feb 23 2023

web ap biology reading guide fred and theresa holtzclaw chapter i i cell communication 27 an idea transcription factors is introduced in figure i 8 explain the function of transcription factors in the cell pr04c tns are a cell aya concept i i 3 transduction cascades of molecular interactions relay signals from receptors to

chapter 6 reading guide completed ap bio studocu - Sep 01 2023

web ap biology reading guide fred and theresa holtzclaw chapter 6 a tour of the cell explain the important role played by peroxisomes contains catalase which converts hydrogen peroxide a waste product of cellular respiration into water with the release of oxygen atoms detoxifies alcohol in liver cells summary

teressa holtzclaw profiles facebook - Oct 10 2021

chapter 1 introduction themes in the study of life - Dec 24 2022

web ap biology fred and theresa holtzclaw study guide chapter two chapter 6 guided reading questions chapter 2 guided

reading biology content campbell biology test bank 11th edition carrara s campbell biology mem pages the rough guide to the brain rough guides reference titles

ap biology reading guide fred and theresa holtzclaw essays and - Aug 20 2022

web ap biology reading guide fred and theresa holtzclaw chapter 55 ap biology study guide online activities chapter 16 ap biology test answers for chapter 10 ap chem lab 4 analysis of alum ap chem lab report determine the empirical formula of silver oxide ap chemistry kinetics lab ap chemistry lab answers hess law ap chemistry lab answers

fred and theresa holtzclaw answer guide nursing study guide - Apr 15 2022

web merely said the fred and theresa holtzclaw study guide answers is universally compatible considering any devices to read preparing for the biology ap exam neil a campbell 2009 11 03 fred and theresa holtzclaw bring over 40 years of ap biology teaching experience to this student manual drawing on their rich experience as readers

ap biology reading guide fred and theresa holtzclaw answers - Jan 13 2022

web william henry holtzclaw 1870 1943 was an educator and the founder of utica institute in mississippi holtzclaw was a graduate of the tuskegee institute and desired to start his own school 1 he settled in utica mississippi bought land on credit and persuaded the locals to appoint him teacher of what was then called the utica negro

ap biology fred and theresa holtzclaw reading guide answers - Jul 19 2022

web whispering the secrets of language an emotional journey through ap biology reading guide fred and theresa holtzclaw answer key in a digitally driven earth where displays reign great and instant connection drowns out the subtleties of language the profound strategies and psychological nuances concealed within phrases usually get unheard

william henry holtzclaw wikipedia - Nov 10 2021

ap reading guide fred and theresa holtzclaw answers chapter 7 - Sep 20 2022

web whispering the strategies of language an psychological quest through ap biology fred and theresa holtzclaw reading guide answers in a digitally driven world where screens reign supreme and instant conversation drowns out the subtleties of language the profound secrets and mental subtleties concealed within phrases frequently move unheard

fred and theresa holtzclaw study guide answers - Feb 11 2022

web 2 55 guide answers fred and theresa holtzclaw 2021 03 29 certification guide second edition presents you with an organized test preparation routine through the use of proven series elements and techniques do i know this already quizzes open each chapter and allow you to decide how much time you need to spend on each section exam

library management systems a survey ijrpr com - Mar 03 2022

web a library management system s goal is to deliver immediate and accurate information about any type of book saving time

and effort the library management system is software that manages a library s manual functions from preserving book records to issuing a book the program aids in the management of the complete library business

[pdf library management system researchgate](#) - May 17 2023

web pdf on jun 17 2021 ahmed seid published library management system find read and cite all the research you need on researchgate

literature review on library management system phdessay - Aug 20 2023

web aug 20 2018 a library management system is a software system that helps manage the cataloging circulation and inventory of library collections it is used to track items in the library such as books magazines and other materials and to manage patron information such as borrowing and returning items

library management system based on recommendation system - May 05 2022

web library management system based on recommendation system fu jia yan shi conference paper 2229 accesses 2 citations part of the communications in computer and information science book series ccis volume 392 abstract with wide application of management system information data grows rapidly

pdf library management system researchgate - Jun 18 2023

web dec 15 2020 baalachandran s abstract with the advancement of technology it is imperative to exalt all the systems into a user friendly manner the library management system lms acts as a tool to

foreign related literature title the state of library management systems - Jun 06 2022

web foreign related literature title the state of library management systems rayson cris sanggoyo technology has been a vital part of improvement in many aspects of life technology can be seen everywhere one particular aspect that technology helps is the maintenance of records

literature review of research on web interface in library management - Oct 10 2022

web jul 1 2011 literature review of research on web interface in library management software systems july 2011 authors shailendra k namrata rai indian institute of management bangalore abstract

school library management a literature review current science - Sep 09 2022

web feb 8 2021 one challenge is the lack of a fair approach to reallocate resources in the library system at school bernardo de souza lopes rodrigues 2020 this happened due to several issues regarding library management in schools first the majority of school libraries are managed by individuals who have no training or background in library

library management systems chapter 19 librarianship - Dec 12 2022

web jun 8 2018 fundamentally an lms does two things it supports all the back end operations of a library acquiring stock information cataloguing stock loaning stock disseminating information and reporting on these functions to

literature review on library management system studymode - Apr 04 2022

web literature review on library management system view writing issues filter results literature review draft karen foss library director of the catawba county library system in newton north carolina has expressed that it is difficult to find materials to help new public library managers cultivate their professional development

migrating to a shared library management system evaluation from the - Jan 13 2023

web may 3 2021 the purpose of this article is to investigate certain aspects problems and benefits from the migration to a shared library management system lms a review of the literature and a quantitative survey was conducted based on a structured questionnaire with a response rate of 44 7 among the crucial issues that should be

library management system an overview sciencedirect topics - Jul 07 2022

web in the case of a library management system the parts work together to support the management of library information resources their acquisition representation and circulation each of these parts constitutes a subsystem which in turn comprises a set of interconnected parts

library management system with topic modelling - Apr 16 2023

web library management system with topic modelling and its adaptability to open and distance learning libraries babafemi richard adebayo radebayo noun edu ng follow this and additional works at https digitalcommons unl edu libphilprac part of the library and information science

the digital library management system 2021 researchgate - Jul 19 2023

web feb 5 2021 the digital library management system 2021 design and implementation of an integrated library management system february 2021 doi thesis for bachelor of science in information

school library management a literature review researchgate - Feb 14 2023

web feb 22 2021 library management school library management a literature review february 2021 authors alifa soraya nuryadika request full text abstract this article aims to find out how school

library management wikipedia - Feb 02 2022

web category v t e library management is a sub discipline of institutional management that focuses on specific issues faced by libraries and library management professionals library management encompasses normal managerial tasks as well as intellectual freedom and fundraising responsibilities

library automation in university a literature review - Jan 01 2022

web apart from the literature on library automation in the university libraries the aspects of the study includes library orientation programme comparative study of library software integrated library systems libraries image analysis imaging systems universities libraries information storage retrieval systems information science open sou

chapter 1 introduction and literature review emery library - Mar 15 2023

web chapter 1 of library technology reports vol 49 no 2 techniques for electronic resource management shows that the literature on electronic resource management is segmented into many different areas of traditional librarian roles within the library

library management emerald publishing - Aug 08 2022

web library management reflects the latest research undertaken in academic government and corporate institutions by reporting contemporary thought whilst also exploring practical implications for those involved in teaching and practice

intelligent libraries a review on expert systems artificial - Nov 11 2022

web jun 30 2020 this paper reviews literature on the application of intelligent systems in the libraries with a special issue on the es ai and robot also it introduces the potential of libraries to use intelligent systems especially es ai and robots design methodology approach