

Industria Industriale
agati-GARELLI
S. r. l.
Monticello Pr (Como)

CICLOMOTORE A DUE RUOTE

« GARELLI 8181 » (NOI MATIC)

Omologato dal Ministero dei Trasporti - Direzione Generale Motorizzazione Civile
e T.C. - Certificato n. 50255 OM in data 10-11-1980
E' autorizzato il rilascio della dichiarazione di conformità di cui all'Art. 53 del T.U. 15-8-1950 n. 300

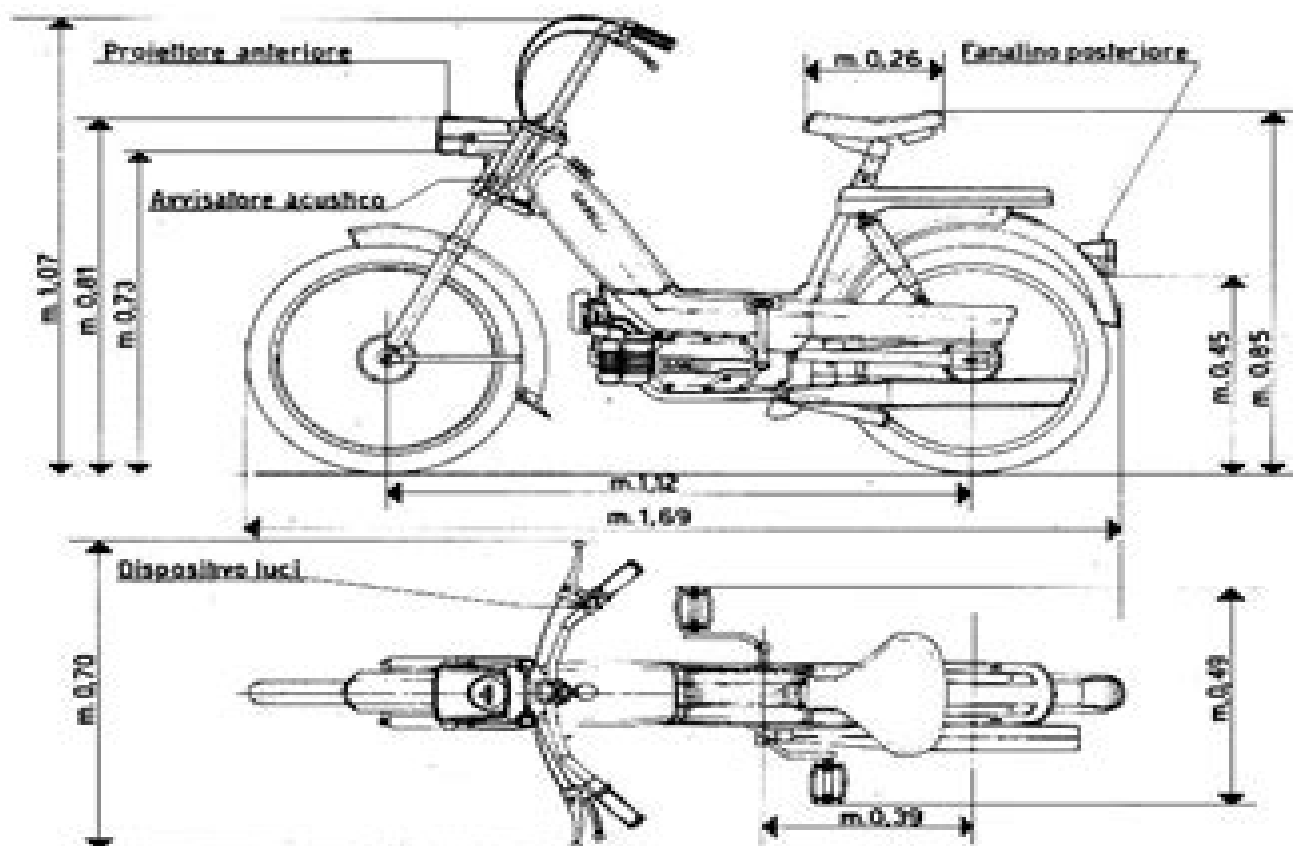

(Ca

TEL

GARELLI 1-8181

Garelli Noi Matic Manual

LP Steffe



Garelli Noi Matic Manual:

Reviewing **Garelli Noi Matic Manual**: Unlocking the Spellbinding Force of Linguistics

In a fast-paced world fueled by information and interconnectivity, the spellbinding force of linguistics has acquired newfound prominence. Its capacity to evoke emotions, stimulate contemplation, and stimulate metamorphosis is really astonishing. Within the pages of "**Garelli Noi Matic Manual**," an enthralling opus penned by a very acclaimed wordsmith, readers embark on an immersive expedition to unravel the intricate significance of language and its indelible imprint on our lives. Throughout this assessment, we shall delve to the book is central motifs, appraise its distinctive narrative style, and gauge its overarching influence on the minds of its readers.

<https://staging.conocer.cide.edu/book/uploaded-files/fetch.php/hunting%20unicorns%20english%20edition.pdf>

Table of Contents Garelli Noi Matic Manual

1. Understanding the eBook Garelli Noi Matic Manual
 - The Rise of Digital Reading Garelli Noi Matic Manual
 - Advantages of eBooks Over Traditional Books
2. Identifying Garelli Noi Matic Manual
 - Exploring Different Genres
 - Considering Fiction vs. Non-Fiction
 - Determining Your Reading Goals
3. Choosing the Right eBook Platform
 - Popular eBook Platforms
 - Features to Look for in an Garelli Noi Matic Manual
 - User-Friendly Interface
4. Exploring eBook Recommendations from Garelli Noi Matic Manual
 - Personalized Recommendations
 - Garelli Noi Matic Manual User Reviews and Ratings
 - Garelli Noi Matic Manual and Bestseller Lists

5. Accessing Garelli Noi Matic Manual Free and Paid eBooks
 - Garelli Noi Matic Manual Public Domain eBooks
 - Garelli Noi Matic Manual eBook Subscription Services
 - Garelli Noi Matic Manual Budget-Friendly Options
6. Navigating Garelli Noi Matic Manual eBook Formats
 - ePub, PDF, MOBI, and More
 - Garelli Noi Matic Manual Compatibility with Devices
 - Garelli Noi Matic Manual Enhanced eBook Features
7. Enhancing Your Reading Experience
 - Adjustable Fonts and Text Sizes of Garelli Noi Matic Manual
 - Highlighting and Note-Taking Garelli Noi Matic Manual
 - Interactive Elements Garelli Noi Matic Manual
8. Staying Engaged with Garelli Noi Matic Manual
 - Joining Online Reading Communities
 - Participating in Virtual Book Clubs
 - Following Authors and Publishers Garelli Noi Matic Manual
9. Balancing eBooks and Physical Books Garelli Noi Matic Manual
 - Benefits of a Digital Library
 - Creating a Diverse Reading Collection Garelli Noi Matic Manual
10. Overcoming Reading Challenges
 - Dealing with Digital Eye Strain
 - Minimizing Distractions
 - Managing Screen Time
11. Cultivating a Reading Routine Garelli Noi Matic Manual
 - Setting Reading Goals Garelli Noi Matic Manual
 - Carving Out Dedicated Reading Time
12. Sourcing Reliable Information of Garelli Noi Matic Manual
 - Fact-Checking eBook Content of Garelli Noi Matic Manual
 - Distinguishing Credible Sources
13. Promoting Lifelong Learning

-
- Utilizing eBooks for Skill Development
 - Exploring Educational eBooks
14. Embracing eBook Trends
- Integration of Multimedia Elements
 - Interactive and Gamified eBooks

Garelli Noi Matic Manual Introduction

Garelli Noi Matic Manual Offers over 60,000 free eBooks, including many classics that are in the public domain. Open Library: Provides access to over 1 million free eBooks, including classic literature and contemporary works. Garelli Noi Matic Manual Offers a vast collection of books, some of which are available for free as PDF downloads, particularly older books in the public domain. Garelli Noi Matic Manual : This website hosts a vast collection of scientific articles, books, and textbooks. While it operates in a legal gray area due to copyright issues, its a popular resource for finding various publications. Internet Archive for Garelli Noi Matic Manual : Has an extensive collection of digital content, including books, articles, videos, and more. It has a massive library of free downloadable books. Free-eBooks Garelli Noi Matic Manual Offers a diverse range of free eBooks across various genres. Garelli Noi Matic Manual Focuses mainly on educational books, textbooks, and business books. It offers free PDF downloads for educational purposes. Garelli Noi Matic Manual Provides a large selection of free eBooks in different genres, which are available for download in various formats, including PDF. Finding specific Garelli Noi Matic Manual, especially related to Garelli Noi Matic Manual, might be challenging as theyre often artistic creations rather than practical blueprints. However, you can explore the following steps to search for or create your own Online Searches: Look for websites, forums, or blogs dedicated to Garelli Noi Matic Manual, Sometimes enthusiasts share their designs or concepts in PDF format. Books and Magazines Some Garelli Noi Matic Manual books or magazines might include. Look for these in online stores or libraries. Remember that while Garelli Noi Matic Manual, sharing copyrighted material without permission is not legal. Always ensure youre either creating your own or obtaining them from legitimate sources that allow sharing and downloading. Library Check if your local library offers eBook lending services. Many libraries have digital catalogs where you can borrow Garelli Noi Matic Manual eBooks for free, including popular titles. Online Retailers: Websites like Amazon, Google Books, or Apple Books often sell eBooks. Sometimes, authors or publishers offer promotions or free periods for certain books. Authors Website Occasionally, authors provide excerpts or short stories for free on their websites. While this might not be the Garelli Noi Matic Manual full book , it can give you a taste of the authors writing style. Subscription Services Platforms like Kindle Unlimited or Scribd offer subscription-based access to a wide range of Garelli Noi Matic Manual eBooks, including some popular titles.

FAQs About Garelli Noi Matic Manual Books

1. Where can I buy Garelli Noi Matic Manual books? Bookstores: Physical bookstores like Barnes & Noble, Waterstones, and independent local stores. Online Retailers: Amazon, Book Depository, and various online bookstores offer a wide range of books in physical and digital formats.
2. What are the different book formats available? Hardcover: Sturdy and durable, usually more expensive. Paperback: Cheaper, lighter, and more portable than hardcovers. E-books: Digital books available for e-readers like Kindle or software like Apple Books, Kindle, and Google Play Books.
3. How do I choose a Garelli Noi Matic Manual book to read? Genres: Consider the genre you enjoy (fiction, non-fiction, mystery, sci-fi, etc.). Recommendations: Ask friends, join book clubs, or explore online reviews and recommendations. Author: If you like a particular author, you might enjoy more of their work.
4. How do I take care of Garelli Noi Matic Manual books? Storage: Keep them away from direct sunlight and in a dry environment. Handling: Avoid folding pages, use bookmarks, and handle them with clean hands. Cleaning: Gently dust the covers and pages occasionally.
5. Can I borrow books without buying them? Public Libraries: Local libraries offer a wide range of books for borrowing. Book Swaps: Community book exchanges or online platforms where people exchange books.
6. How can I track my reading progress or manage my book collection? Book Tracking Apps: Goodreads, LibraryThing, and Book Catalogue are popular apps for tracking your reading progress and managing book collections. Spreadsheets: You can create your own spreadsheet to track books read, ratings, and other details.
7. What are Garelli Noi Matic Manual audiobooks, and where can I find them? Audiobooks: Audio recordings of books, perfect for listening while commuting or multitasking. Platforms: Audible, LibriVox, and Google Play Books offer a wide selection of audiobooks.
8. How do I support authors or the book industry? Buy Books: Purchase books from authors or independent bookstores. Reviews: Leave reviews on platforms like Goodreads or Amazon. Promotion: Share your favorite books on social media or recommend them to friends.
9. Are there book clubs or reading communities I can join? Local Clubs: Check for local book clubs in libraries or community centers. Online Communities: Platforms like Goodreads have virtual book clubs and discussion groups.
10. Can I read Garelli Noi Matic Manual books for free? Public Domain Books: Many classic books are available for free as they're in the public domain. Free E-books: Some websites offer free e-books legally, like Project Gutenberg or Open Library.

Find Garelli Noi Matic Manual :

hunting unicorns english edition

hunger games probability teaching guide

husqvarna 250 chainsaw repair manual

human resources management 11th edition gary dessler

husqvarna 250 electronic manual

human resources manual template

human physiology from cells to systems instructors

hummer h3 2006 manual

hunter ceiling fans manual

~~husqvarna 350 chainsaw workshop manual~~

humans in the biosphere guided sec 1

~~hunter sprinkler instruction manual~~

human inheritance and pedigree analysis labr

humble thyself chords

~~husband in chastity english edition~~

Garelli Noi Matic Manual :

Choosing Health by Lynch, April ... brief personal health textbook. The 3rd Edition offers guidance for actively improving individuals' health while new interactive videos, quizzes, activities ... Choosing Health - Books 0134554213 / 9780134554211

Choosing Health, Books a la Carte Edition. Read more. About the Author. April Lynch, MA. April Lynch is an award-winning author and ... Choosing Health The 3rd Edition offers guidance for actively improving students' health while new interactive videos, quizzes, activities, and worksheets in Mastering™ Health ... Choosing Health (2nd Edition) - Lynch, April; Elmore, Barry

Choosing Health (2nd Edition) by Lynch, April; Elmore, Barry; Kotecki, Jerome - ISBN 10: 0321929659 - ISBN 13: 9780321929655 - Pearson - 2014 - Softcover.

Choosing health brief edition lynch (Read Only) - resp.app If you ally dependence such a referred choosing health brief edition lynch books that will provide you worth, get the unquestionably best seller from us ... Choosing Health by: April Lynch - 9780134636306 ... brief personal health textbook. The 3rd Edition offers guidance for actively improving individuals' health while new interactive videos, quizzes, activities ... Choosing Health The 3rd Edition offers guidance for actively improving students' health while new interactive videos, quizzes, activities, and

worksheets in ... Books by April Lynch Choosing Health(3rd Edition) by April Lynch, Karen Vail-Smith, Jerome Edward Kotecki, Laura Bonazzoli Paperback, 496 Pages, Published 2017 by Pearson Choosing Health / Edition 3 by April Lynch ... brief personal health textbook. The 3rd Edition offers guidance for actively improving individuals' health while new interactive videos, quizzes, activities ... Choosing Health 3rd Edition.c3 4 PDF April Lynch, M.A.. April Lynch is an award-winning author and journalist who specializes in health, the medical and biological sciences, and human genetics ...

Managerial Accounting Third Canadian Edition Instructor's ... Managerial Accounting Third Canadian Edition Instructor's Solutions Manual Building Blocks of Managerial Accounting Quick Check Questions Answers. Solution Manual 9780134526270 Managerial Accounting ... Jul 28, 2020 — Managerial Accounting Canadian 3rd edition by Karen W. Braun, Wendy M. Tietz, Louis Beaubien Solution Manual Link full download solution ... Third Canadian Edition - Student Solutions Manual Management Accounting: Third Canadian Edition - Student Solutions Manual - Picture 1 of 1. 1 Photos. Management Accounting: Third Canadian Edition - Student ... Managerial Accounting Canadian 3rd Edition Braun Managerial Accounting Canadian 3rd Edition Braun Solutions Manual - Free download as Word Doc (.doc / .docx), PDF File (.pdf), Text File (.txt) or read ... Cornerstones Of Managerial Accounting Canadian 3rd ... Apr 14, 2019 — Cornerstones Of Managerial Accounting Canadian 3rd Edition Mowen Solutions Manual Full Download: ... Instructor Solutions Manual for Use with Managerial ... Instructor Solutions Manual for Use with Managerial Accounting, Third Canadian Edition. Authors, Brenda M. Mallouk, Gary Spraakman. Edition, illustrated. Managerial Accounting Third Canadian Edi Managerial Accounting Third Canadian Edition Instructor's Solutions Manual 87 · Chapter 2. Building Blocks of Managerial Accounting ; Managerial Accounting Third ... Solution Manual for Managerial Accounting Canadian 3rd Solution Manual for Managerial Accounting Canadian 3rd Edition Braun Tietz Beaubien 0134151844 9780134151847 - Free download as PDF File (.pdf), ... Cornerstones of Managerial Accounting, 3rd Canada May 4, 2023 — ... (Solution Manual). Course; Cornerstones of Managerial Accounting, 3rd Canada. Institution; Cornerstones Of Managerial Accounting, 3rd Canada. Solution Manual for Managerial Accounting Intro Chapter 1 solution manual for pearson book on intro to managerial accounting. Short answers, Exercises and problems all included. full file at solution ... What happened to Deeper in You? - FAQs - Sylvia Day What happened to Deeper in You? - FAQs - Sylvia Day Reflected in You (Crossfire, Book 2) eBook : Day, Sylvia Reflected in You (Crossfire, Book 2) by [Sylvia Day] ... Sylvia Day is the #1 New York Times and #1 international bestselling author of over 20 award-winning ... Reflected in You (Crossfire, #2) by Sylvia Day Read 11.3k reviews from the world's largest community for readers. Gideon Cross. As beautiful and flawless on the outside as he was damaged and tormented o... Reflected in You (A Crossfire Novel) by Sylvia Day Book Review - Reflected in you (Crossfire #2) - Sylvia Day The second chapter in Eva and Gideon's story is one that will enthrall you, emotionally hurt you ... Reflected in You (A Crossfire Novel #2) (Paperback) By Sylvia Day ; Description. The sensual saga of Eva and Gideon continues in the second novel in the #1 New York Times bestselling Crossfire series. Gideon Cross ...

Reflected in You - Crossfire Series, Book 2 Oct 2, 2012 — The second novel in the searingly romantic series following Gideon Cross and Eva Tramell, written by Sylvia Day. The Crossfire Saga, Book 2. Reflected in You (Crossfire Series #2) The sensual saga of Eva and Gideon continues in the second novel in the #1 New York Times bestselling Crossfire series. Gideon Cross. What is the correct reading order for the Crossfire Saga? What is the correct reading order for the Crossfire Saga? · Bared to You · Reflected in You · Entwined with You · Captivated by You · One with You. Review: Reflected in You by Sylvia Day Nov 5, 2012 — Gideon Cross. As beautiful and flawless on the outside as he was damaged and tormented on the inside. He was a bright, scorching flame that ... Book Review - Reflected In You by Sylvia Day Oct 4, 2012 — Reflected in You: Book #2 in the Crossfire Series (see my review for book#1 - Bared To You, if you haven't read this yet.