

FOG LIGHT RELAYS

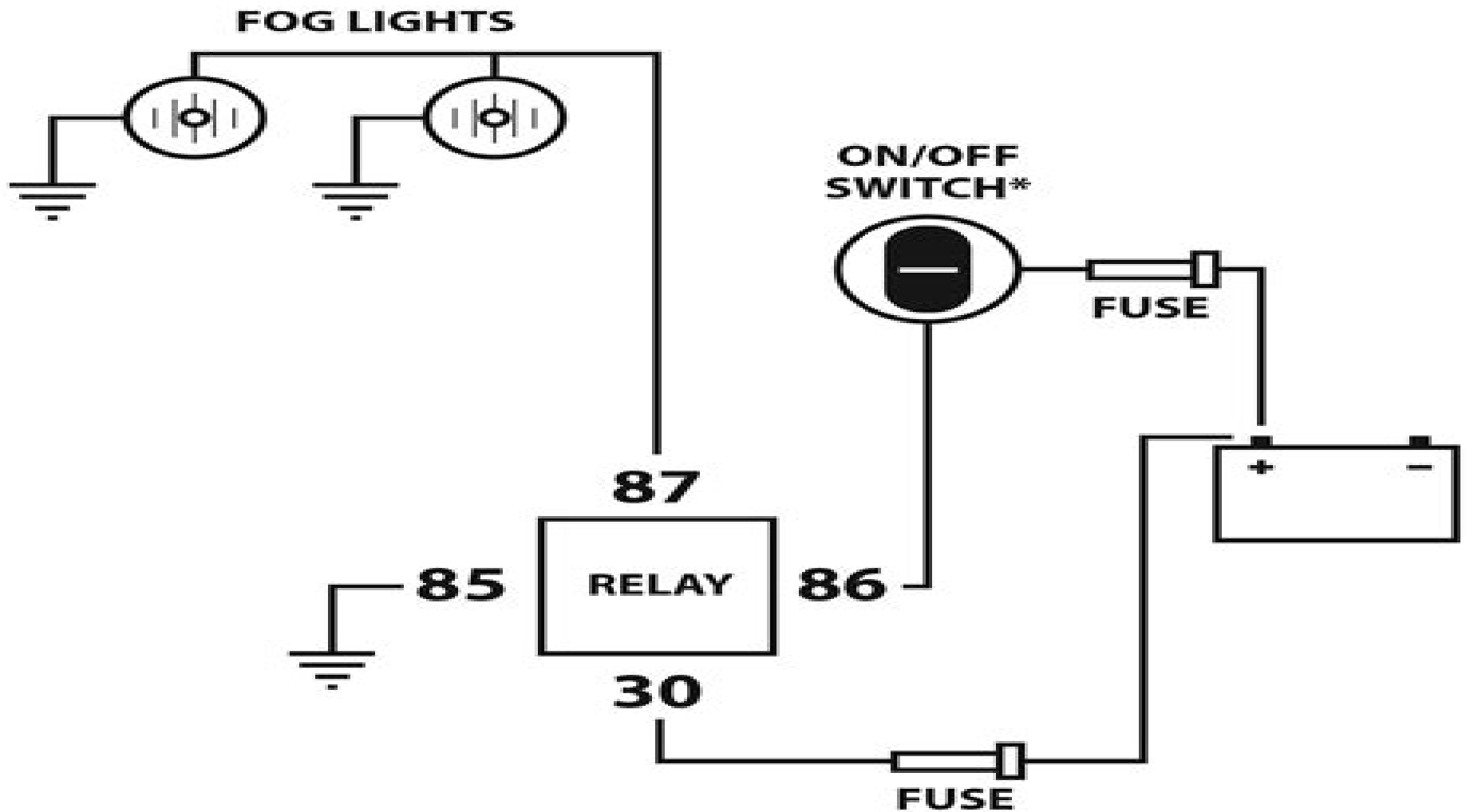

*As an alternative, instead of running directly from the positive terminal to the fog lights' on/off switch, run power from the headlights after the headlight switch to the fog lights' on/off switch so the fog lights will not go on unless the headlights are on.

How To Wire Fog Lights Diagram

Tom Denton



How To Wire Fog Lights Diagram:

Advanced Automotive Electricity and Electronics Klyde, Kirk Vangelder, 2017-06-12 Advanced Automotive Electricity and Electronics published as part of the CDX Master Automotive Technician Series gives students with a basic understanding of automotive electrical the additional knowledge and experience they need to diagnose and fix complex electrical systems and circuits Focused on a strategy based diagnostics approach this book helps students master technical trouble shooting in order to address the problem correctly on the first attempt Motor 1988 General Motors Wiring Diagram Manual ,1989

Automotive Electricity and Electronics Jones, 2017-05-23 Suitable for students with no experience in electricity and electronics this volume in the CDX Master Automotive Technician Series introduces students to the basic skills and tools they need to perform electrical diagnosis in the shop Utilizing a strategy based diagnostics approach this book helps students master technical trouble shooting in order to properly resolve the customer concern on the first attempt Automotive Technician Training: Theory Tom Denton, 2014-04-16 A blended learning approach to automotive engineering at levels one to three Produced alongside the ATT online learning resources this textbook covers all the theory and technology sections that students need to learn in order to pass levels 1 2 and 3 automotive courses It is recommended by the Institute of the Motor Industry and is also ideal for exams run by other awarding bodies Unlike the current textbooks on the market though this title takes a blended learning approach using interactive features that make learning more enjoyable as well as more effective When linked with the ATT online resources it provides a comprehensive package that includes activities video footage assessments and further reading Information and activities are set out in sequence so as to meet teacher and learner needs as well as qualification requirements Tom Denton is the leading UK automotive author with a teaching career spanning lecturer to head of automotive engineering in a large college His nine automotive textbooks published since 1995 are bestsellers and led to his authoring of the Automotive Technician Training multimedia system that is in common use in the UK USA and several other countries **Automobile Mechanical and Electrical Systems** Tom Denton, 2011-05-23 This textbook will help you learn all the skills you need to pass Level 3 and 4 Vehicle Maintenance and Repair courses from City and Guilds IMI and BTEC and is also ideal for higher level ASE AUR and other qualifications Advanced Automotive Fault Diagnosis covers the fundamentals of vehicle systems and components and explains the latest diagnostic techniques employed in effective vehicle maintenance and repair Diagnostics or fault finding is an essential part of an automotive technician s work and as automotive systems become increasingly complex there is a greater need for good diagnostics skills For students new to the subject this book will help to develop these skills but will also assist experienced technicians in further improving their performance and keeping up with recent industry developments In full colour and including examples of the latest technology this is the guide that no student enrolled on an automotive maintenance and repair course should be without Fundamentals of Medium/Heavy Duty Commercial Vehicle Systems Gus Wright, Owen C. Duffy, 2019-07

Thoroughly updated and expanded Fundamentals of Medium Heavy Duty Commercial Vehicle Systems Second Edition offers comprehensive coverage of basic concepts building up to advanced instruction on the latest technology including distributed electronic control systems energy saving technologies and automated driver assistance systems Now organized by outcome based objectives to improve instructional clarity and adaptability and presented in a more readable format all content seamlessly aligns with the latest ASE Medium Heavy Truck Program requirements for MTST Back cover Auto Wiring Diagrams for Passenger Cars Harold Frederick Blanchard,1954 Completely Morgan Ken Hill,1994 For owners and would be owners of four wheeled four cylinder engined Morgans Ken Hill has created an invaluable Bible which is absolutely packed with genuinely useful information Ken sets the stage by detailing the history of the Morgan motor company describes the marque s motorsport record and then in great detail chronicles the evolution of each four cylinder model Next comes a huge amount of practical advice on maintenance repair and modification of these cars advice based on information gathered over a number of years from a host of Morgan owners and specialists around the world This book s guidance on restoration techniques will prove to be a real boon to those undertaking a rebuild or considering the purchase of a car in need of restoration Again this advice is based upon experience as Ken restored his own concours winning Morgan Part of the Morgan experience is the social scene that embraces the marque on a worldwide basis so Ken devotes a whole chapter to Morgan clubs and their activities The last part of the book is a series of appendices comprised of technical data sheets wiring diagrams lubrication charts Lucas electrical equipment data sheets details of specialists distributors and manufacturers and details of Morgan miniature models Altogether this work is a unique source book of essential information for all Morgan owners and enthusiasts **Computer-Based Diagnostic Systems** Chris Price,2012-12-06 Computer based diagnostic systems are among the most successful applications of knowledge based systems KBS technology Chris Price shows the best way to build effective diagnostic systems for different types of diagnostic problems by giving examples of different solutions to the problem of building effective diagnostic systems helping you to decide on an appropriate strategy for building a diagnostic system to aid troubleshooting of that diagnostic problem showing how to use diagnostic fault trees as a common representation for discussing different ways of approaching diagnosis Computer Based Diagnostic Systems is written in such a way as to make the material easy to understand even when you do not have easy access to the commercial tools

Popular Science ,1951-06 Popular Science gives our readers the information and tools to improve their technology and their world The core belief that Popular Science and our readers share The future is going to be better and science and technology are the driving forces that will help make it better Volkswagen Jetta, Golf, GTI Service Manual Bentley Publishers,2003 Bentley Publishers is the exclusive factory authorized publisher of Volkswagen Service Manuals in the United States and Canada In every manual we provide full factory repair procedures specifications tolerances electrical wiring diagrams and lubrication and maintenance information Bentley manuals are the only complete authoritative source of

Volkswagen maintenance and repair information Even if you never intend to service your car yourself you ll find that owning a Bentley Manual will help you to discuss repairs more intelligently with your service technician

Practical Motorsport Engineering Andrew Livesey,2018-12-07 This guide and textbook on motorsport engineering is written from a practical point of view It offers a wide ranging insight into the nuts and bolts technology of practical car racing from saloons and sports cars to open wheelers It gives the aspiring race engineer the tools to do the job by explaining all aspects of race car technology and offering crucial insight into the essentials of the motorsport engineering industry For motorsport engineering students at all levels this book particularly covers the examination syllabuses for IMI the Institute of the Motor Industry EAL and BTEC and meets the CPD requirements of most engineering institutions Each aspect of the race car is covered in a separate chapter with test questions and suggestions for further study at the end Combining the key points from his previous publications Basic Motorsport Engineering and Advanced Motorsport Engineering the author draws on a career in teaching and industry to create the must have all in one reference It is an ideal companion for the practising owner driver or race engineer whether amateur or professional a suitable introductory text for HND and degree students and a great point of reference for any other keen fans with an interest in motorsport

Land Rover Series II, IIA and III Maintenance and Upgrades Manual Richard Hall,2016-06-30 Based on real life experience and written by expert authors the books in the Maintenance and Upgrades Manual series from Crowood will help owners develop the workshop skills needed for the maintenance and repair of their cars and give guidance on possibilities for improvements and upgrades to performance With step by step instructions and safety information throughout this book is a valuable technical resource for owners of Series II IIA and III Land Rovers The book covers choosing and buying a Series II or III Land Rover maintenance and service procedures detailed guides for repair and maintenance of each of the car s systems including brakes steering and suspension engine clutch and transmission axles hubs and propshafts and electrical systems repairing and preventing corrosion upgrades for reliability comfort performance and off roading rebuilding a Series II or III Land Rover things to know before you take on a project car This practical guide and technical resource for all Series II IIA and III owners and Land Rover enthusiasts is fully illustrated with over 280 colour photographs

Automotive Electrical Handbook Inkwell Co. Inc.,1987-01-01 When it s time to wire your car whether it s a restoration project race car kit car trailer or street rod don t be intimidated wire it yourself Jim Horner shares his years of experience and cuts through the technical jargon to show you how Learn about basic electrical theory how various electrical components work and drawing circuit diagrams Includes tips on using electrical test equipment and troubleshooting electrical circuits Choose the right components build your own wiring harness and install them by following the step by step instructions Profusely illustrated with over 350 photos drawings and diagrams Suppliers list included

Physics Through Applications Ken Stewart,1989 By using the applications of physics concepts this book will challenge motivate and stimulate all your students Written for Standard Grade it is also used

extensively for GCSE Each topic on a double page spread including essential physics in summary form Applies physics to the real world Suitable for both Standard Grade Physics and GCSE courses with a physics content *Operator's and Organizational Maintenance Manual, Including Repair Parts and Special Tools List* ,1990 *The Railway Engineer* ,1908

The Essential Guide to Motorcycle Maintenance Mark Zimmerman,2016-12-15 A guide to motorcycle maintenance that explains how to perform the basic and essential maintenance tests with easy to follow instructions and tips for dealing with problems **Motor Age** ,1939 **Hillier's Fundamentals of Automotive Electronics** V. A. W. Hillier,1996 Adapted and expanded to meet all the requirements of motor vehicle NVQs at levels 2 and 3 this book includes numerous features to help the student learn and relates theory to workplace practice

Embark on a breathtaking journey through nature and adventure with its mesmerizing ebook, Witness the Wonders in **How To Wire Fog Lights Diagram** . This immersive experience, available for download in a PDF format (*), transports you to the heart of natural marvels and thrilling escapades. Download now and let the adventure begin!

<https://staging.conocer.cide.edu/About/scholarship/default.aspx/emergency%20a%20city%20hospital%20novel%20english%20edition.pdf>

Table of Contents How To Wire Fog Lights Diagram

1. Understanding the eBook How To Wire Fog Lights Diagram
 - The Rise of Digital Reading How To Wire Fog Lights Diagram
 - Advantages of eBooks Over Traditional Books
2. Identifying How To Wire Fog Lights Diagram
 - Exploring Different Genres
 - Considering Fiction vs. Non-Fiction
 - Determining Your Reading Goals
3. Choosing the Right eBook Platform
 - Popular eBook Platforms
 - Features to Look for in an How To Wire Fog Lights Diagram
 - User-Friendly Interface
4. Exploring eBook Recommendations from How To Wire Fog Lights Diagram
 - Personalized Recommendations
 - How To Wire Fog Lights Diagram User Reviews and Ratings
 - How To Wire Fog Lights Diagram and Bestseller Lists
5. Accessing How To Wire Fog Lights Diagram Free and Paid eBooks
 - How To Wire Fog Lights Diagram Public Domain eBooks
 - How To Wire Fog Lights Diagram eBook Subscription Services
 - How To Wire Fog Lights Diagram Budget-Friendly Options

6. Navigating How To Wire Fog Lights Diagram eBook Formats
 - ePub, PDF, MOBI, and More
 - How To Wire Fog Lights Diagram Compatibility with Devices
 - How To Wire Fog Lights Diagram Enhanced eBook Features
7. Enhancing Your Reading Experience
 - Adjustable Fonts and Text Sizes of How To Wire Fog Lights Diagram
 - Highlighting and Note-Taking How To Wire Fog Lights Diagram
 - Interactive Elements How To Wire Fog Lights Diagram
8. Staying Engaged with How To Wire Fog Lights Diagram
 - Joining Online Reading Communities
 - Participating in Virtual Book Clubs
 - Following Authors and Publishers How To Wire Fog Lights Diagram
9. Balancing eBooks and Physical Books How To Wire Fog Lights Diagram
 - Benefits of a Digital Library
 - Creating a Diverse Reading Collection How To Wire Fog Lights Diagram
10. Overcoming Reading Challenges
 - Dealing with Digital Eye Strain
 - Minimizing Distractions
 - Managing Screen Time
11. Cultivating a Reading Routine How To Wire Fog Lights Diagram
 - Setting Reading Goals How To Wire Fog Lights Diagram
 - Carving Out Dedicated Reading Time
12. Sourcing Reliable Information of How To Wire Fog Lights Diagram
 - Fact-Checking eBook Content of How To Wire Fog Lights Diagram
 - Distinguishing Credible Sources
13. Promoting Lifelong Learning
 - Utilizing eBooks for Skill Development
 - Exploring Educational eBooks
14. Embracing eBook Trends
 - Integration of Multimedia Elements

- Interactive and Gamified eBooks

How To Wire Fog Lights Diagram Introduction

Free PDF Books and Manuals for Download: Unlocking Knowledge at Your Fingertips In today's fast-paced digital age, obtaining valuable knowledge has become easier than ever. Thanks to the internet, a vast array of books and manuals are now available for free download in PDF format. Whether you are a student, professional, or simply an avid reader, this treasure trove of downloadable resources offers a wealth of information, conveniently accessible anytime, anywhere. The advent of online libraries and platforms dedicated to sharing knowledge has revolutionized the way we consume information. No longer confined to physical libraries or bookstores, readers can now access an extensive collection of digital books and manuals with just a few clicks. These resources, available in PDF, Microsoft Word, and PowerPoint formats, cater to a wide range of interests, including literature, technology, science, history, and much more. One notable platform where you can explore and download free How To Wire Fog Lights Diagram PDF books and manuals is the internet's largest free library. Hosted online, this catalog compiles a vast assortment of documents, making it a veritable goldmine of knowledge. With its easy-to-use website interface and customizable PDF generator, this platform offers a user-friendly experience, allowing individuals to effortlessly navigate and access the information they seek. The availability of free PDF books and manuals on this platform demonstrates its commitment to democratizing education and empowering individuals with the tools needed to succeed in their chosen fields. It allows anyone, regardless of their background or financial limitations, to expand their horizons and gain insights from experts in various disciplines. One of the most significant advantages of downloading PDF books and manuals lies in their portability. Unlike physical copies, digital books can be stored and carried on a single device, such as a tablet or smartphone, saving valuable space and weight. This convenience makes it possible for readers to have their entire library at their fingertips, whether they are commuting, traveling, or simply enjoying a lazy afternoon at home. Additionally, digital files are easily searchable, enabling readers to locate specific information within seconds. With a few keystrokes, users can search for keywords, topics, or phrases, making research and finding relevant information a breeze. This efficiency saves time and effort, streamlining the learning process and allowing individuals to focus on extracting the information they need. Furthermore, the availability of free PDF books and manuals fosters a culture of continuous learning. By removing financial barriers, more people can access educational resources and pursue lifelong learning, contributing to personal growth and professional development. This democratization of knowledge promotes intellectual curiosity and empowers individuals to become lifelong learners, promoting progress and innovation in various fields. It is worth noting that while accessing free How To Wire Fog Lights Diagram PDF books and manuals is convenient and cost-effective, it is vital to respect copyright laws and intellectual property rights. Platforms offering free downloads often operate within legal

boundaries, ensuring that the materials they provide are either in the public domain or authorized for distribution. By adhering to copyright laws, users can enjoy the benefits of free access to knowledge while supporting the authors and publishers who make these resources available. In conclusion, the availability of How To Wire Fog Lights Diagram free PDF books and manuals for download has revolutionized the way we access and consume knowledge. With just a few clicks, individuals can explore a vast collection of resources across different disciplines, all free of charge. This accessibility empowers individuals to become lifelong learners, contributing to personal growth, professional development, and the advancement of society as a whole. So why not unlock a world of knowledge today? Start exploring the vast sea of free PDF books and manuals waiting to be discovered right at your fingertips.

FAQs About How To Wire Fog Lights Diagram Books

How do I know which eBook platform is the best for me? Finding the best eBook platform depends on your reading preferences and device compatibility. Research different platforms, read user reviews, and explore their features before making a choice. Are free eBooks of good quality? Yes, many reputable platforms offer high-quality free eBooks, including classics and public domain works. However, make sure to verify the source to ensure the eBook credibility. Can I read eBooks without an eReader? Absolutely! Most eBook platforms offer webbased readers or mobile apps that allow you to read eBooks on your computer, tablet, or smartphone. How do I avoid digital eye strain while reading eBooks? To prevent digital eye strain, take regular breaks, adjust the font size and background color, and ensure proper lighting while reading eBooks. What the advantage of interactive eBooks? Interactive eBooks incorporate multimedia elements, quizzes, and activities, enhancing the reader engagement and providing a more immersive learning experience. How To Wire Fog Lights Diagram is one of the best book in our library for free trial. We provide copy of How To Wire Fog Lights Diagram in digital format, so the resources that you find are reliable. There are also many Ebooks of related with How To Wire Fog Lights Diagram. Where to download How To Wire Fog Lights Diagram online for free? Are you looking for How To Wire Fog Lights Diagram PDF? This is definitely going to save you time and cash in something you should think about. If you trying to find then search around for online. Without a doubt there are numerous these available and many of them have the freedom. However without doubt you receive whatever you purchase. An alternate way to get ideas is always to check another How To Wire Fog Lights Diagram. This method for see exactly what may be included and adopt these ideas to your book. This site will almost certainly help you save time and effort, money and stress. If you are looking for free books then you really should consider finding to assist you try this. Several of How To Wire Fog Lights Diagram are for sale to free while some are payable. If you arent sure if the books you would like to download works with for usage along with your computer, it is possible to download free trials. The

free guides make it easy for someone to free access online library for download books to your device. You can get free download on free trial for lots of books categories. Our library is the biggest of these that have literally hundreds of thousands of different products categories represented. You will also see that there are specific sites catered to different product types or categories, brands or niches related with How To Wire Fog Lights Diagram. So depending on what exactly you are searching, you will be able to choose e books to suit your own need. Need to access completely for Campbell Biology Seventh Edition book? Access Ebook without any digging. And by having access to our ebook online or by storing it on your computer, you have convenient answers with How To Wire Fog Lights Diagram To get started finding How To Wire Fog Lights Diagram, you are right to find our website which has a comprehensive collection of books online. Our library is the biggest of these that have literally hundreds of thousands of different products represented. You will also see that there are specific sites catered to different categories or niches related with How To Wire Fog Lights Diagram So depending on what exactly you are searching, you will be able to choose ebook to suit your own need. Thank you for reading How To Wire Fog Lights Diagram. Maybe you have knowledge that, people have search numerous times for their favorite readings like this How To Wire Fog Lights Diagram, but end up in harmful downloads. Rather than reading a good book with a cup of coffee in the afternoon, instead they juggled with some harmful bugs inside their laptop. How To Wire Fog Lights Diagram is available in our book collection an online access to it is set as public so you can download it instantly. Our digital library spans in multiple locations, allowing you to get the most less latency time to download any of our books like this one. Merely said, How To Wire Fog Lights Diagram is universally compatible with any devices to read.

Find How To Wire Fog Lights Diagram :

[emergency a city hospital novel english edition](#)

[elna jubilee service manual](#)

eli 10beginner level instructor pacing guide

[emarketing excellence third edition ning](#)

[elvis ing and selling guide](#)

[elle est venue vous dire](#)

emachines hardware compatibility guide

[elna 2004 manual](#)

[ellya comment tout a commenceacute](#)

elizabeth ii la derniegrave reine

[elna top 3sewing machine manual](#)

[email marketing and lucid offers focus on demand](#)

emanation of leaders magnificence global omnipotence of community leadership approach

emachines g720 manual

[email introduction myself](#)

How To Wire Fog Lights Diagram :

recipe for a book club a monthly guide for hostin laura calder - Mar 02 2022

web you could purchase guide recipe for a book club a monthly guide for hostin or acquire it as soon as feasible you could speedily download this recipe for a book club a monthly guide for hostin after getting deal

[recipe for a book club a monthly guide for hosting you](#) - Sep 20 2023

web oct 31 2004 recipe for a book club a monthly guide for hosting your own reading group mary o hare rose storey 3 31 35 ratings8 reviews unlike other basic reading group guides recipe for a book club combines good eating with good reading for the millions of americans who participate in book clubs

recipe for a book club a monthly guide for hostin - Aug 07 2022

web great interest to book clubs looking to gain insight into how other groups run and learn best practices it is also very relevant to libraries and booksellers who advise book club members or host their own book clubs additionally authors and publishers wishing to understand the dynamics of book clubs will much of interest

how to host the ultimate book club party better homes gardens - Mar 14 2023

web updated on october 1 2022 you ve gathered your closest friends and chosen your favorite books and now it s your turn to host the next book club meeting a book club is a great way to get friends together and with our easy tips hosting it doesn t have to be stressful

the 30 best recipes for your book club taste of home - Dec 11 2022

web aug 4 2021 laura denby caroline stanko updated aug 04 2021 sometimes it s tough to choose the right read for your book club picking a good recipe can be even harder we ve got our favorite book club snacks to fit the theme of your next meeting our editors and experts handpick every product we feature we may earn a commission from your

[recipe for a book club a monthly guide for hosting your own](#) - Apr 15 2023

web written by two sisters who formed their own monthly reading and lunch groups that continue to meet recipe for a book club starts in january and ends in december with a reading theme for

recipe for a book club a monthly guide for hostin download - Jul 18 2023

web recipe for a book club a monthly guide for hostin 1 recipe for a book club a monthly guide for hostin the story of edgar

sawtelle the recipe box the light we lost eat your words the kids book club book plots and pans the lives of diamond bessie one day in december the book of lost names the paris wife the lincoln highway

how to plan the best book club party ever taste of home - Jun 05 2022

web jan 18 2019 taste of home host a book club for your foodie friends with culinary delights on the page and the table

recipe for a book club a monthly guide for hosting your own - May 16 2023

web oct 1 2004 recipe for a book club by mary o hare rose storey october 2004 capital books edition hardcover in english

recipe for a book club a monthly guide for hosting your own reading group by mary o hare open library

dinner and a book book club dinner menu ideas myrecipes - May 04 2022

web jul 29 2009 lemon curd pimm s no 1 cup bel canto ann patchett offer your book club members a south american menu

as a tribute to the unnamed south american county where the novel takes place argentine black bean flatbread with

chimichurri drizzle chayote and hearts of palm cebiche salad pineapple sorbet the devil in the white

pdf recipe for a book club a monthly guide for hostin - Apr 03 2022

web recipe for a book club a monthly guide for hostin 9 months may 16 2020 can you believe that every one of us started as a tiny egg in our mummy s belly one tiny cell not bigger than a speck of dust will grow into a baby in just nine months time in this book we

recipe for a book club a monthly guide for hosting your own - Jan 12 2023

web recipe for a book club a monthly guide for hosting your own reading group hardcover o hare marystorey rose 3 32 avg

rating 34 ratings by goodreads hardcover isbn 10 1931868832 isbn 13 9781931868839 publisher capital books 2004 this

specific isbn edition is currently not available view all copies of this isbn

[recipe for a book club a monthly guide for hosting your own](#) - Feb 13 2023

web abebooks com recipe for a book club a monthly guide for hosting your own reading group new copy customer service

guaranteed recipe for a book club a monthly guide for hosting your own reading group by storey rose new hardcover 2004

goldbooks

[recipe for a book club a monthly guide for hosting your own](#) - Oct 21 2023

web recipe for a book club a monthly guide for hosting your own reading group o hare mary storey rose amazon sg books

recipe for a book club a monthly guide for hosting your own reading - Aug 19 2023

web oct 22 2004 recipe for a book club a monthly guide for hosting your own reading group hardcover october 22 2004

unlike other basic reading group guides recipe for a book club combines good eating with good reading for the millions of americans who participate in book clubs

recipe for a book club a monthly guide for hosting your own - Oct 09 2022

web browse and save recipes from recipe for a book club a monthly guide for hosting your own reading group to your own online collection at eatyourbooks com

recipe for a book club a monthly guide for hosting your own - Jun 17 2023

web an illustration of an open book books an illustration of two cells of a film strip video an illustration of an audio speaker audio an illustration of a 3 5 floppy disk software an illustration of two photographs images an illustration of a heart shape donate an

book club recipe ideas oprah com - Nov 10 2022

web aug 13 2013 just simmer a big pot of white beans in a savory tomato sauce and then sprinkle it with tangy feta cheese it takes about eight hours to cook so you can start it in the morning and forget about it until dinnertime leaving you a full day to finish the book get the recipe giant beans in tomato sauce photo jonny valiant

all the book club dinner ideas you ll ever need peanut blossom - Sep 08 2022

web jan 27 2023 there are two ways you could approach a book club dinner every member takes turns hosting the host picks the book plans the meal and does all the work once and then gets to enjoy all the other book club meetings as a guest potluck style every member takes turns hosting and picking the book of the month

recipe for a book club a monthly guide for hostin pdf - Jul 06 2022

web recipe for a book club a monthly guide for hostin make time for a home centered life jan 20 2023 a guide for planning success as a family includes goal setting calendaring journaling family counsels family home evening activities games and treats bradshaw s monthly railway and steam navigation guide mar 10 2022 february

calcutta university question paper 2022 download semester exam paper - Oct 19 2023

web calcutta university question paper 2022 calcutta university releases the question paper every year after the commencement of examinations for all undergraduate and postgraduate students to check and download from its

calcutta university chemistry honours question my question paper - Dec 09 2022

web dec 26 2019 it is university question paper of chemistry honours of the year 2019 the only motive to publish the question paper on this blog is to help the students to understand the question format it is original version of the question paper download the pdf attachment and take a print out

free calcutta university b sc chemistry question paper - Feb 28 2022

web calcutta university b sc chemistry question paper physics for degree students b sc second year jun 06 2022 for b sc second year students as per ugc model curriculum for all indian universities the book is presented in a comprehensive way using simple language the sequence of articles in each chapter enables the students to

calcutta university b sc chemistry question paper pdf 2023 - Oct 07 2022

web calcutta university b sc chemistry question paper pdf oswaal icse question bank class 10 chemistry book for 2023 24 exam apr 26 2021 description of the product 100 updated with board specimen paper exam papers crisp revision topic wise revision notes mind maps mnemonics extensive practice with 3000

course curriculum under choice university of calcutta - May 14 2023

web 1 course curriculum under choice based credit system syllabus for bachelor in chemistry honours university of calcutta 2 course structure cours e credits theory practical core course cc theory

pdf calcutta university b sc chemistry question paper - Apr 13 2023

web calcutta university b sc chemistry question paper oswaal cbse physics chemistry biology class 12 sample question papers set of 3 books for 2023 board exam based on cbse sample paper released on 16th september dec 19 2020 this product covers the following 10 sample papers 5 solved 5 self

university of calcutta old question papers pdf free download - Sep 18 2023

web university of calcutta old question papers pdf free download here you can find out university of calcutta uoc solved question paper of the year 2022 2021 2020 2019 2018 2017 also you can download this cu question paper in pdf format *calcutta university b sc chemistry question paper pdf* - Jun 03 2022

web calcutta university b sc chemistry question paper pdf chemistry for b sc students semester ii nep up aug 14 2020 this textbook has been designed to meet the needs of b sc second semester students of chemistry as per common minimum syllabus prescribed for all uttar pradesh state universities and colleges under

chemistry g 2021 general 2nd semester the question paper - May 02 2022

web oct 21 2021 2021 chemistry general paper ge cc 2 full marks 50 candidates are required to give their answers in their own words as far as practicable english version the figures in the margin indicate full marks 1 answer any twenty questions 1 20 a identify the following as open closed or isolated system i the

dr sudipta chatterjee question papers of calcutta university - Jan 10 2023

web question papers of calcutta university examination of previous years b sc honours semester system examination under cbcs syllabus 2018 2019 academic year 2018 present

c u question papers - Jul 16 2023

web all question papers of calcutta university have been posted below download the pdf files b sc under cbcs 2nd sem chemistry h 2019

calcutta university chemistry general question paper 2022 - Jul 04 2022

web year name of examination 1 1891 entrance examination first examination in artsquestion papers university of calcuttaif you are looking for b sc chemistry general part i question papers of the university of calcutta then here it is chemistry

general part i question paper of the

calcutta university b sc chemistry general part my question paper - Jun 15 2023

web nov 17 2015 if you are looking for b sc chemistry general part i question papers of the university of calcutta then here it is chemistry general part i question paper of the year 2013 it will surely help you to understand the type of questions pattern asked in the exam for first year b sc students

calcutta university question paper download pdf online - Nov 08 2022

web nov 7 2023 1st semester question paper 3rd semester question paper download all question paper click here calcutta university previous year question papers part iii semester iv and semester vi 2021 examination b a b sc b com semester 3 semester 5 theory 2020 question paper 2018

calcutta university question paper chemistry g 2018 - Aug 05 2022

web apr 4 2020 best of luck calcutta university question paper examination calcutta university 1st semester paper ge cc i year 2018 category new question cum answer booklet subject chemistry calcutta university question paper 2020 the university of calcutta conducts the entrance exam for selecting candidates

calcutta university chemistry general question paper - Sep 06 2022

web calcutta university chemistry general question paper syllabi for three year b sc honours general courses of calcutta university admission 2020 entrance exam last calcutta university chemistry general question city college kolkata university question paper 2018 calcutta university question papers

b sc cc 11 12 2020 sem 5 chemistry honours question paper calcutta - Mar 12 2023

web b sc chemistry honours question paper cc 11 physical chemistry cc 12 organic chemistry university calcutta university cbcsemester 5thlanguage english b

pdf download calcutta university chemistry honours question paper - Apr 01 2022

web aug 20 2021 calcutta university question paper 2020 2021 1st semester question paper chemistry hons b sc 1st semester question paper cu question paper pdf download chemistry hons 1st semester cc 2 cu question paper free pdf download of question paper

calcutta university b sc chemistry question paper pdf - Feb 11 2023

web calcutta university b sc chemistry question paper oswaal cbse sample question papers class 12 chemistry for 2023 exam jul 22 2021 this product covers the following 10 sample papers 5 solved 5 self assessment papers strictly designed as per the latest cbse sample paper

cu question paper download pdf b a b sc b com all - Aug 17 2023

web jun 25 2023 calcutta university question paper pdf download online exam 2023 calcutta university exam question

papers for ug and pg semesters are available here you can download the calcutta university b a b sc b com m a m sc m com exam question papers from the link given here

the american republic since 1877 online student edition - Jul 03 2023

web for high school students the american republic since 1877 presents the rich saga of american history after the civil war the modern history portion of the american vision this program features the same exceptional scholarship up to date accurate maps

[the american republic since 1877 glencoe mheducation com](#) - Mar 31 2023

web the american republic since 1877 chapter 14 world war i and its aftermath 1914 1920 world war i and its aftermath 1914 1920

the american republic since 1877 reading essentials and - Jan 29 2023

web oct 21 2022 american republic since 1877 reading essentials and study guide glencoe mcgraw hill free download borrow and streaming internet archive

[the american republic since 1877 glencoe mheducation com](#) - Sep 05 2023

web the american republic since 1877 textbook resources click an item at the left to access links activities and more once your teacher has registered for the online student edition he or she will give you the user name and password needed to view the book

the american republic since 1877 student edition glencoe - Nov 26 2022

web oct 28 2023 american republic since 1877 team teaching interdisciplinary strategies and activities mcgraw hill staff 2002 06 american republic to 1877 unit 4 resources glencoe mcgraw hill 2002 05 01 american republic to 1877 unit 6 resources

the american republic since 1877 archive org - Feb 27 2023

web jan 12 2006 the american republic since 1877 reading essentials and study guide workbook by mcgraw hill january 12 2006 glencoe mcgraw hill edition paperback in english 1 edition the american republic since 1877 reading essentials and study

glencoe the american republic since 1877 bbb ed - Oct 26 2022

web glencoe american republic since 1877 resources 1 downloaded from old restorative justice org on 2020 12 06 by guest as recognized adventure as with ease as experience very nearly lesson amusement as without difficulty as concord can be gotten

glencoe american republic since 1877 resources pdf copy - Aug 24 2022

web state resources ngs map machine textbook resources online student edition multi language glossaries study central study

to go web links chapter activities chapter overviews student web activities self check quizzes epuzzles and games

[american republic since 1877 reading essentials and study guide](#) - Dec 28 2022

web apr 8 2004 the american republic since 1877 student edition glencoe by mcgraw hill april 8 2004 glencoe mcgraw hill edition hardcover in english 2 edition

[the american republic since 1877 2007 mcgraw hill education](#) - Mar 19 2022

web the american republic since 1877 georgia edition beyond the textbook state resources time election connection time notebook time state resources time election connection time notebook time current events update ngs mapmachine

the american republic since 1877 georgia edition - Feb 15 2022

web the american republic to 1877 textbook resources click an item at the left to access links activities and more once your teacher has registered for the online student edition he or she will give you the user name and password needed to view the book additional

[the american republic since 1877 glencoe mheducation com](#) - Dec 16 2021

[the american republic since 1877 2007 mcgraw hill education](#) - May 21 2022

web glencoe partners 1 0k the american republic to 1877 the student center includes the teacher center includes access to all our student center activities and resources plus partners sites teacher forum teaching today research literature

the american republic since 1877 glencoe com retirement - Jun 21 2022

web please read our terms of use and privacy notice before you explore our web site to report a technical problem with this web site please contact the web producer web

the american republic since 1877 mcgraw hill education - Oct 06 2023

web glencoe partners 1 0k the american republic since 1877 the student center includes beyond the textbook state resources ngs mapmachine textbook resources online student edition multi language glossaries web links study

the american republic to 1877 2007 mcgraw hill education - Jul 23 2022

web the american republic since 1877 beyond the textbook state resources ngs mapmachine textbook resources online student edition multi language glossaries web links study unit resources chapter activities home social studies home

the american republic since 1877 student edition - Aug 04 2023

web jan 25 2002 for high school students the american republic since 1877 presents the rich saga of american history after the civil war the modern history portion of the american vision this

the american republic to 1877 glencoe com retirement june - Jan 17 2022

web the american republic since 1877 the student center includes beyond the textbook state games vocabulary eflashcards

interactive maps the teacher center includes access to all our student center activities and resources plus partners sites teacher

the american republic since 1877 archive org - Jun 02 2023

web english xxxvii 9 19 670 pages 29 cm grade 11 national geographic includes bibliographical references english and spanish glossaries and index unit 1 foundations of liberty beginnings 1848 unit 2 the crisis of union 1848 1877 unit 3 the birth of

the american republic since 1877 open library - May 01 2023

web mar 15 2023 imported from bcl marc marc record the american republic since 1877 by joyce oldham appleby phd 2007 glencoe mcgraw hill glencoe mcgraw hill pub edition in english teacher wraparound ed

glencoe american republic since 1877 resources - Sep 24 2022

web glencoe american r lic since 1877 resources pdf 3 3 offer an analysis of 24 insurgencies and summarize world war ii underground rules of clandestine behavior report documentation page the armed forces and democracy in latin america

the american republic to 1877 mcgraw hill education - Apr 19 2022

web textbook resources online student edition multi language glossaries web links study central study to go chapter activities chapter overviews student web activities self check quizzes epuzzles and games vocabulary eflashcards interactive maps the