

Note: top of the shift lever boot to be pushed below the raised section on the lever

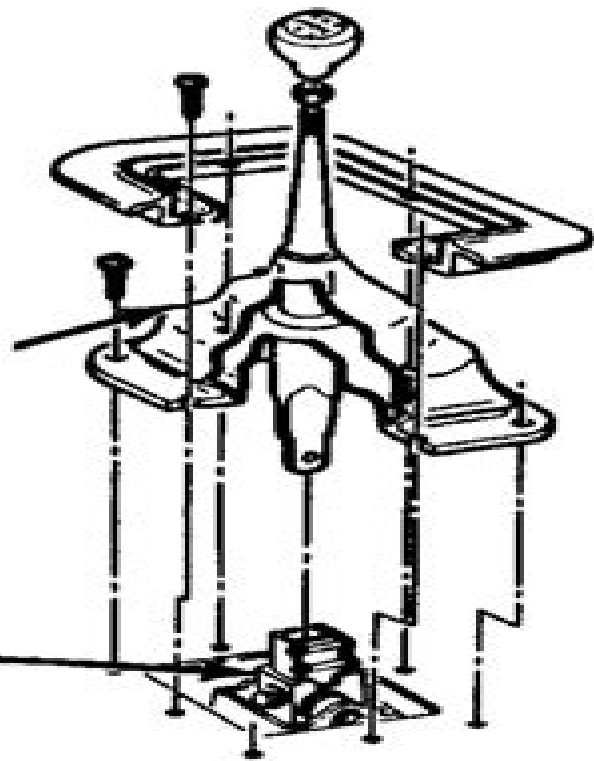

Trans control assembly

36 ft. lbs. (50 Nm)

30 ft. lbs. (40 Nm)

36 ft. lbs. (50 Nm)

36 ft. lbs. (50 Nm)

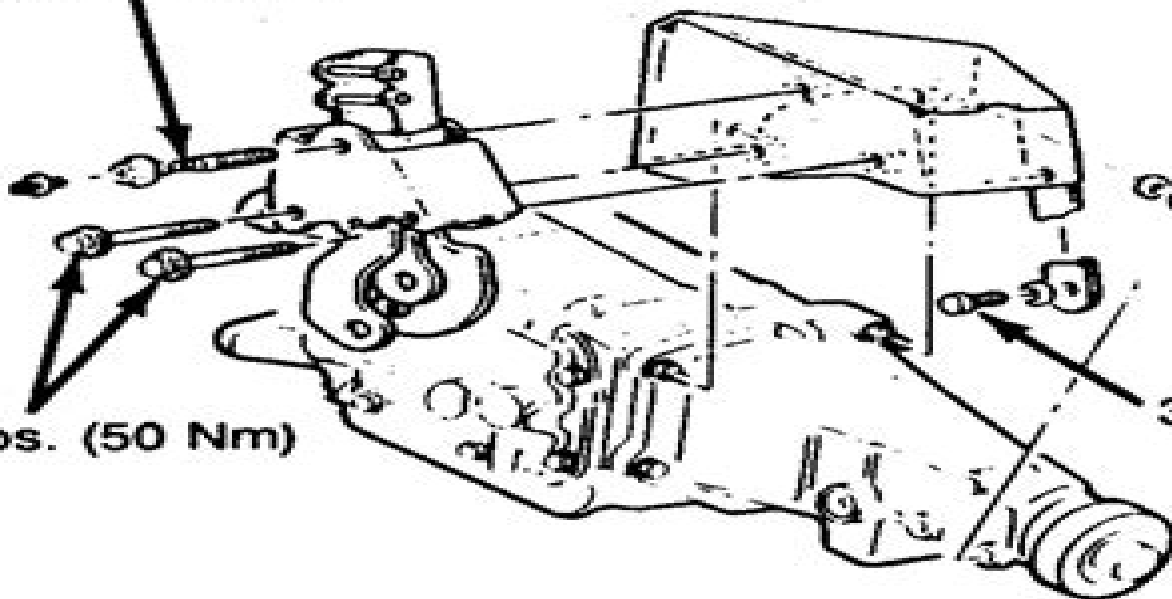

Ford Ranger Manual Transmission Shifter Parts

Jimmy Dinsmore, James Halderman



Ford Ranger Manual Transmission Shifter Parts:

93 - 97 Ford Ranger Repair Manual , This is the PDF service repair manual for the Ford Ranger 1993 1997 The same manual autoshops and dealers reference to This isnt your everyday off the shelf autostore manual This manual is guranteed to be better than any autostore manual Detailed drawings Detail diagrams Detail step by step instructions Covers more than standard manuals Available as PDF no more damage manuals Chapters include Body Frame and Mounting Engine Suspension Driveline Brakes Transmission Clutch Exhaust system Fuel system Steering Climate Control system Instrumentation and Warning systems Battery and charging system Audio system Lighting Electrical Power supply **How to Build a Hot Rod Model A Ford** Dennis Parks, *Cars & Parts* ,2002 *Ford F-Series Trucks: 1948-Present* Jimmy Dinsmore,James Halderman,2023-02-17 Learn about the entire history of America s best selling vehicle the Ford F Series truck When Henry Ford first started manufacturing Model Ts more than 100 years ago he didn t really have any sort of pickup or truck configuration in mind However enterprising people and businesses were modifying those early chassis for commercial use and it didn t take long for Ford to figure out that there was a demand for a truck application of the Model T Soon Ford was making its own configurations for commercial use first through third party body companies and eventually by Ford itself with the Model TT From these humble beginnings Ford stumbled onto the basis for one of the most popular vehicles ever built the Ford F Series pickup truck In *Ford F Series Trucks 1948 Present* authors Jimmy Dinsmore and James Halderman thoroughly dissect the history of Ford F Series pickup trucks as seen from a technical viewpoint Fully covered are all the options chassis specifications running changes and the evolution of these trucks as they transformed from postwar utilitarian vehicles to the best selling luxury family cruisers seen today Not only are Ford trucks the best selling trucks they are the best selling vehicle of any category cars included This book will thrill truck aficionados and Ford historians alike as it covers the first F Series models 1948 1952 the ever popular second generation F Series models 1953 1956 the popular Bumpsides 1967 1972 and all the way through the remarkable technology of what is now the 14th generation of the F Series **Chilton's Ford Repair Manual, 1980-1987** ,1987 The total Ford manual for multi vehicle owners information for all models cars and light trucks **Chilton's Truck and Van Repair Manual, 1977-1984** ,1984 Ford Pickup Trucks Mike Mueller,2008 **Chilton's Truck and Van Repair Manual** ,1986 *Lemon-Aid Used Cars and Trucks 2011-2012* Phil Edmonston,2011-04-25 As Toyota skids into an ocean of problems and uncertainty continues in the U S automotive industry *Lemon Aid Used Cars and Trucks 20112012* shows buyers how to pick the cheapest and most reliable vehicles from the past 30 years *Lemon Aid guides* are unlike any other car and truck books on the market Phil Edmonston Canada s automotive Dr Phil for 40 years pulls no punches Like five books in one *Lemon Aid Used Cars and Trucks* is an expos of car scams and gas consumption lies a do it yourself service manual an independent guide that covers beaters lemons and collectibles an archive of secret service bulletins granting free repairs and a legal primer that even lawyers cant beat Phil delivers the goods on free

fixes for Chrysler Ford and GM engine transmission brake and paint defects lets you know about Corvette and Mustang tops that fly off gives the lowdown on Honda Hyundai and Toyota engines and transmissions and provides the latest information on computer module glitches

Lemon-Aid Used Cars and Trucks 2012-2013 Phil Edmonston,2012-05-19 A guide to buying a used car or minivan features information on the strengths and weaknesses of each model a safety summary recalls warranties and service tips

Lemon-Aid Used Cars and Trucks 2010-2011 Phil Edmonston,2010-05-11 The automotive maven and former Member of Parliament might be the most trusted man in Canada an inverse relationship to the people he writes about The Globe and Mail Lemon Aid shows car and truck buyers how to pick the cheapest and most reliable vehicles from the past 30 years of auto production This brand new edition of the bestselling guide contains updated information on secret service bulletins that can save you money Phil describes sales and service scams lists which vehicles are factory goofs and sets out the prices you should pay As Canada s automotive Dr Phil for over 40 years Edmonston pulls no punches His Lemon Aid is more potent and provocative than ever

Popular Mechanics ,2003-06 Popular Mechanics inspires instructs and influences readers to help them master the modern world Whether it s practical DIY home improvement tips gadgets and digital technology information on the newest cars or the latest breakthroughs in science PM is the ultimate guide to our high tech lifestyle

Disaster in Dearborn Thomas E. Bonsall,2002 Tells the disastrous story of the design and development of the Edsel with insights into this spectacular failure of the automobile industry to sell a car that it had marketed extensively

The Used Car Reliability and Safety Guide Adam Berliant,1997 Completely updated this compilation of consumer complaints from the National Highway Traffic Safety Administration arms used car shoppers with the facts they need to purchase a reliable vehicle and avoid ending up with someone else s problems

Popular Mechanics ,1984-04 Popular Mechanics inspires instructs and influences readers to help them master the modern world Whether it s practical DIY home improvement tips gadgets and digital technology information on the newest cars or the latest breakthroughs in science PM is the ultimate guide to our high tech lifestyle

Car and Driver ,2003-07 Off-road High-performance Handbook Michael Bargo,1988

Consumer Reports Used Car Buying Guide Consumer Reports Books Editors,2001-02 Consumer Reports Used Car Buying Guide gives shoppers comprehensive advice on more than 200 models including reliability histories for 1992 1999 models of cars SUVs minivans and pickup trucks 225 photos charts

New Car Buying Guide Consumer Reports (Firm),2006-06 This essential guide offers all the tools necessary to negotiate for the best price including reliability ratings profiles and crash test results for more than 210 new car models

Automobile Book 1998 Consumer Guide,Consumer Guide Editors,1998-01-19 Whether you re interested in passenger cars sport utility vehicles trucks or minivans all are discussed in this invaluable guide to the new 1998 vehicles Over 165 cars trucks and vans are reviewed and rated in every important category from price to handling to options Don t make an uninformed decision get the guide that takes the hassle out of car buying

Ignite the flame of optimism with Get Inspired by is motivational masterpiece, **Ford Ranger Manual Transmission Shifter Parts** . In a downloadable PDF format (Download in PDF: *), this ebook is a beacon of encouragement. Download now and let the words propel you towards a brighter, more motivated tomorrow.

<https://staging.conocer.cide.edu/public/scholarship/index.jsp/gran%20globo%20de%20barney%20el.pdf>

Table of Contents Ford Ranger Manual Transmission Shifter Parts

1. Understanding the eBook Ford Ranger Manual Transmission Shifter Parts
 - The Rise of Digital Reading Ford Ranger Manual Transmission Shifter Parts
 - Advantages of eBooks Over Traditional Books
2. Identifying Ford Ranger Manual Transmission Shifter Parts
 - Exploring Different Genres
 - Considering Fiction vs. Non-Fiction
 - Determining Your Reading Goals
3. Choosing the Right eBook Platform
 - Popular eBook Platforms
 - Features to Look for in an Ford Ranger Manual Transmission Shifter Parts
 - User-Friendly Interface
4. Exploring eBook Recommendations from Ford Ranger Manual Transmission Shifter Parts
 - Personalized Recommendations
 - Ford Ranger Manual Transmission Shifter Parts User Reviews and Ratings
 - Ford Ranger Manual Transmission Shifter Parts and Bestseller Lists
5. Accessing Ford Ranger Manual Transmission Shifter Parts Free and Paid eBooks
 - Ford Ranger Manual Transmission Shifter Parts Public Domain eBooks
 - Ford Ranger Manual Transmission Shifter Parts eBook Subscription Services
 - Ford Ranger Manual Transmission Shifter Parts Budget-Friendly Options
6. Navigating Ford Ranger Manual Transmission Shifter Parts eBook Formats

- ePub, PDF, MOBI, and More
 - Ford Ranger Manual Transmission Shifter Parts Compatibility with Devices
 - Ford Ranger Manual Transmission Shifter Parts Enhanced eBook Features
7. Enhancing Your Reading Experience
 - Adjustable Fonts and Text Sizes of Ford Ranger Manual Transmission Shifter Parts
 - Highlighting and Note-Taking Ford Ranger Manual Transmission Shifter Parts
 - Interactive Elements Ford Ranger Manual Transmission Shifter Parts
 8. Staying Engaged with Ford Ranger Manual Transmission Shifter Parts
 - Joining Online Reading Communities
 - Participating in Virtual Book Clubs
 - Following Authors and Publishers Ford Ranger Manual Transmission Shifter Parts
 9. Balancing eBooks and Physical Books Ford Ranger Manual Transmission Shifter Parts
 - Benefits of a Digital Library
 - Creating a Diverse Reading Collection Ford Ranger Manual Transmission Shifter Parts
 10. Overcoming Reading Challenges
 - Dealing with Digital Eye Strain
 - Minimizing Distractions
 - Managing Screen Time
 11. Cultivating a Reading Routine Ford Ranger Manual Transmission Shifter Parts
 - Setting Reading Goals Ford Ranger Manual Transmission Shifter Parts
 - Carving Out Dedicated Reading Time
 12. Sourcing Reliable Information of Ford Ranger Manual Transmission Shifter Parts
 - Fact-Checking eBook Content of Ford Ranger Manual Transmission Shifter Parts
 - Distinguishing Credible Sources
 13. Promoting Lifelong Learning
 - Utilizing eBooks for Skill Development
 - Exploring Educational eBooks
 14. Embracing eBook Trends
 - Integration of Multimedia Elements
 - Interactive and Gamified eBooks

Ford Ranger Manual Transmission Shifter Parts Introduction

Free PDF Books and Manuals for Download: Unlocking Knowledge at Your Fingertips In today's fast-paced digital age, obtaining valuable knowledge has become easier than ever. Thanks to the internet, a vast array of books and manuals are now available for free download in PDF format. Whether you are a student, professional, or simply an avid reader, this treasure trove of downloadable resources offers a wealth of information, conveniently accessible anytime, anywhere. The advent of online libraries and platforms dedicated to sharing knowledge has revolutionized the way we consume information. No longer confined to physical libraries or bookstores, readers can now access an extensive collection of digital books and manuals with just a few clicks. These resources, available in PDF, Microsoft Word, and PowerPoint formats, cater to a wide range of interests, including literature, technology, science, history, and much more. One notable platform where you can explore and download free Ford Ranger Manual Transmission Shifter Parts PDF books and manuals is the internet's largest free library. Hosted online, this catalog compiles a vast assortment of documents, making it a veritable goldmine of knowledge. With its easy-to-use website interface and customizable PDF generator, this platform offers a user-friendly experience, allowing individuals to effortlessly navigate and access the information they seek. The availability of free PDF books and manuals on this platform demonstrates its commitment to democratizing education and empowering individuals with the tools needed to succeed in their chosen fields. It allows anyone, regardless of their background or financial limitations, to expand their horizons and gain insights from experts in various disciplines. One of the most significant advantages of downloading PDF books and manuals lies in their portability. Unlike physical copies, digital books can be stored and carried on a single device, such as a tablet or smartphone, saving valuable space and weight. This convenience makes it possible for readers to have their entire library at their fingertips, whether they are commuting, traveling, or simply enjoying a lazy afternoon at home. Additionally, digital files are easily searchable, enabling readers to locate specific information within seconds. With a few keystrokes, users can search for keywords, topics, or phrases, making research and finding relevant information a breeze. This efficiency saves time and effort, streamlining the learning process and allowing individuals to focus on extracting the information they need. Furthermore, the availability of free PDF books and manuals fosters a culture of continuous learning. By removing financial barriers, more people can access educational resources and pursue lifelong learning, contributing to personal growth and professional development. This democratization of knowledge promotes intellectual curiosity and empowers individuals to become lifelong learners, promoting progress and innovation in various fields. It is worth noting that while accessing free Ford Ranger Manual Transmission Shifter Parts PDF books and manuals is convenient and cost-effective, it is vital to respect copyright laws and intellectual property rights. Platforms offering free downloads often operate within legal boundaries, ensuring that the materials they provide are either in the public domain or authorized for distribution. By adhering to copyright laws, users can enjoy the benefits of free access to

knowledge while supporting the authors and publishers who make these resources available. In conclusion, the availability of Ford Ranger Manual Transmission Shifter Parts free PDF books and manuals for download has revolutionized the way we access and consume knowledge. With just a few clicks, individuals can explore a vast collection of resources across different disciplines, all free of charge. This accessibility empowers individuals to become lifelong learners, contributing to personal growth, professional development, and the advancement of society as a whole. So why not unlock a world of knowledge today? Start exploring the vast sea of free PDF books and manuals waiting to be discovered right at your fingertips.

FAQs About Ford Ranger Manual Transmission Shifter Parts Books

1. Where can I buy Ford Ranger Manual Transmission Shifter Parts books? Bookstores: Physical bookstores like Barnes & Noble, Waterstones, and independent local stores. Online Retailers: Amazon, Book Depository, and various online bookstores offer a wide range of books in physical and digital formats.
2. What are the different book formats available? Hardcover: Sturdy and durable, usually more expensive. Paperback: Cheaper, lighter, and more portable than hardcovers. E-books: Digital books available for e-readers like Kindle or software like Apple Books, Kindle, and Google Play Books.
3. How do I choose a Ford Ranger Manual Transmission Shifter Parts book to read? Genres: Consider the genre you enjoy (fiction, non-fiction, mystery, sci-fi, etc.). Recommendations: Ask friends, join book clubs, or explore online reviews and recommendations. Author: If you like a particular author, you might enjoy more of their work.
4. How do I take care of Ford Ranger Manual Transmission Shifter Parts books? Storage: Keep them away from direct sunlight and in a dry environment. Handling: Avoid folding pages, use bookmarks, and handle them with clean hands. Cleaning: Gently dust the covers and pages occasionally.
5. Can I borrow books without buying them? Public Libraries: Local libraries offer a wide range of books for borrowing. Book Swaps: Community book exchanges or online platforms where people exchange books.
6. How can I track my reading progress or manage my book collection? Book Tracking Apps: Goodreads, LibraryThing, and Book Catalogue are popular apps for tracking your reading progress and managing book collections. Spreadsheets: You can create your own spreadsheet to track books read, ratings, and other details.
7. What are Ford Ranger Manual Transmission Shifter Parts audiobooks, and where can I find them? Audiobooks: Audio recordings of books, perfect for listening while commuting or multitasking. Platforms: Audible, LibriVox, and Google Play Books offer a wide selection of audiobooks.

8. How do I support authors or the book industry? Buy Books: Purchase books from authors or independent bookstores. Reviews: Leave reviews on platforms like Goodreads or Amazon. Promotion: Share your favorite books on social media or recommend them to friends.
9. Are there book clubs or reading communities I can join? Local Clubs: Check for local book clubs in libraries or community centers. Online Communities: Platforms like Goodreads have virtual book clubs and discussion groups.
10. Can I read Ford Ranger Manual Transmission Shifter Parts books for free? Public Domain Books: Many classic books are available for free as they're in the public domain. Free E-books: Some websites offer free e-books legally, like Project Gutenberg or Open Library.

Find Ford Ranger Manual Transmission Shifter Parts :

gran globo de barney el

graham swifts last orders a readers guide

government and economic development a publication of the economic growth center yale university

graffiti in the ivy league the seven sisters and thereabouts

governance and public security

grammar links text 2

government of the fifth republic

govt tx&1ky a/c webct

grammaire progresive de francais

grand pianola score full score

grand plans business progressivism and social change in ohios miami valley 1890-1929

grammar sense 3

~~gower handbook of training and development~~

graham a day in billys life

grace awakening swindoll bible study guide

Ford Ranger Manual Transmission Shifter Parts :

sample resignation letter for one treasurer 3 samples - Jun 25 2022

web sep 24 2022 wee both our partners use cookies to store and or gain information switch a device we additionally our

partnering use data for personalised ads furthermore

resignation letter from society treasurer position - May 05 2023

web aug 29 2023 your resignation letter from the society treasurer position should be brief to the point and professional it should contain your name the date of your letter the

how to write an effective resignation letter from treasurer - Jan 01 2023

web aug 2 2023 clear statement of resignation begin your letter by clearly stating your intention to resign from the club treasurer position use a direct and concise sentence

how to write a professional resignation letter from treasurer - Mar 03 2023

web dear ms roth please accept this letter as my resignation from my position as treasurer with the company name pta my final day acting in this capacity will be april 28 2015 i

israel hamas war convoy of five trucks hit by fire as it happened - Mar 23 2022

web i am writing this letter to inform you about my resignation for being a treasurer of housing society from date when you start until present this is because state your reason for

treasurer resignation letter tony simao norco gop - Jan 21 2022

web nov 3 2023 jazmine hughes an award winning new york times magazine staff writer resigned from the publication on friday after she violated the newsroom s policies by

resignation letter from society treasurer position - May 25 2022

web sep 24 2022 in this submit we will be displaying one number of samples of resignation letters for a treasurer resignation leave letters stress management words is

sample resignation letter for a treasurer 3 samples - Jul 07 2023

web oct 24 2023 how to write a professional resignation letter from teaching position learn how to effectively write a resignation letter from your position as the society s

ex senior chief ordered to pay back sh4m he earned after - Jul 15 2021

web format of resign letter post of treasurer treasurer resign letters reassignment as society treasurer response to church position resignation letter 1210 community

i am treasurer of society committee and i want to resign can you - Aug 16 2021

web sep 18 2017 respected sir madam in our co operative housing society the strength of committee members is 15 nos the chairman secretary treasure and joint secretary

letter of resignation from the treasurer of an association - Oct 30 2022

web sep 22 2023 1 start with a polite and professional opening begin by addressing the recipient in a respectful manner

start with dear followed by their name or a formal

resignation by treasurer civil law lawyersclubindia - Dec 20 2021

web treasurer resignation letter tony simao norco gop free download as pdf file pdf text file txt or read online for free
quechee lakes corporation quechee

resignation letter for treasurer housing society ask me fast - Apr 23 2022

web may 10 2023 in this article we will guide you through the process of writing a resignation letter from society treasurer
position with useful tips and examples if you need to

how to write best resignation letter from society - Aug 08 2023

here is a professional example resignation letter for a society treasurer position vijay pundit society treasurer 91 9876512435
vijay pundit email com 7 see more

treasurer resignation letter letter samples livecareer - Apr 04 2023

web oct 1 2023 a resignation letter from society treasurer position is a formal letter that informs the society s board
members about your decision to step down from your

resignation letter sample for sk treasurer how to write and - Nov 30 2022

web aug 17 2023 the best structure for a resignation letter from a treasurer position should begin with a salutation
addressing the appropriate recipient such as the president of the

sample resignation letter for a treasurer 3 samples - Jul 27 2022

web oct 4 2023 we and our partners use cookies to store and or access information on a equipment we and our partners use
data for personalised ads and content ad and

sample resignation letter for a treasurer 3 samples - Aug 28 2022

web sep 24 2022 includes this post we will be displaying a phone of samples of resignation letters for a treasurer en fr de es
computers hr sv sr sl nl data

resignation letter from society treasurer position a step by - Sep 09 2023

here is a template of a resignation letter that you can refer to and adjust according to your preferences first name last name
designation in the committee see more

sample resignation letter for a treasurer 3 samples - Sep 28 2022

web please accept this letter as my resignation from my position as treasurer of the specify name of association my last day
as interim treasurer will be specify date i am being

how to write a resignation letter from club treasurer - Feb 02 2023

web sep 20 2023 letter of resignation from treasurer position due to health reasons dear name of board members i am

writing this letter to resign from my position as

imran hussain labour frontbencher resigns in support of gaza - Oct 18 2021

web b the secretary or treasurer of the society may resign his office as secretary or treasurer by a letter addressed to the chairman of the society c

cooperative society chairman resignation indian kaanoon - Nov 18 2021

web nov 21 2017 resignation by treasurer dear sir madam i am resident and member of a co op hsg society located at pune city suddenly treasurer has submitted his

how to write a professional resignation letter from society - Jun 06 2023

web apr 10 2023 please accept this letter as my resignation from my position as treasurer with the company name pta my final day acting in this capacity will be june 28 2022 i

resignation of chairman secretary and treasure together - Sep 16 2021

web nov 8 2023 first published on tue 7 nov 2023 19 45 est a member of labour s frontbench has resigned with a heavy heart over the party s position on the israel

jazmine hughes resigns from new york times after signing - Feb 19 2022

web nov 7 2023 the palestine red crescent society ongoing humanitarian catastrophe in gaza differs substantially from the position you have adopted hussain said in a

resignation letter from a society treasurer position - Oct 10 2023

here are the steps you can follow to write a professional resignation letter from a society treasurer position see more

plaza sitiada norberto fuentes archive org - Jun 12 2023

web mar 22 2023 plaza sitiada norberto fuentes topics dictadura comunista collection opensource revela la constante repartición de armas de cuba a chile durante la unidad

[la plaza sitiada la joven cuba](#) - Dec 06 2022

web plaza sitiada entre dos siglos by carmen plaza 2014 ediciones carena edition in spanish español primera edición

plaza sitiada plaza carmen amazon com tr kitap - Aug 14 2023

web arama yapmak istediğiniz kategoriye seçin

plaza sitiada by pita juana rosa paperback 1987 - Jan 07 2023

web konuklar istanbul ramada konaklamaları süresince oda servisi ve concierge hizmetlerine erişebilir ayrıca ramada plaza istanbul city center havuz ve oturma salonu olanakları

ramada plaza by wyndham istanbul city center tripadvisor - Nov 05 2022

web oct 27 2015 radio cuba libre internacional plaza sitiada rueda de zello canal trabajos politicos1 conversatorio sobre

elecciones en venezuela y transcision de

plaza sitiada spanish translator - Jul 01 2022

web sep 6 2023 maslak büyükdere caddesi Üzerinde tam müstakil plaza telefonu göster mesaj sariyer maslak mahallesi 38 14 850 000 tl 04 09 2023 satılık plaza 2 bölüm

İstanbul satılık plaza fiyatları İlanları hepsiemlak - Mar 29 2022

web plaza sitiada by norberto fuentes plaza sitiada spanish edition fuentes norberto bolivia revolutions and beyond fall 2011 cuba a view from the island revista the harvard review

ramada plaza by wyndham istanbul city center - May 31 2022

web in the heart of istanbul near to the congress center our five star hotel is right across the osmanbey metro station and only a walking distance to the luxurious shopping fashion

plaza sitiada entre dos siglos 2014 edition open library - Oct 04 2022

web abebooks com plaza sitiada poesía carena spanish edition 9788416054138 by plaza arnáz carmen and a great selection of similar new used and collectible books

plaza sitiada spanish edition amazon com - May 11 2023

web jul 25 2018 un punto de giro tan dramático como insoslayable en la historia del comunismo cubano y del que norberto fuentes precisamente fue uno de los

plaza sitiada proverbio en un acto en verso archive org - Oct 24 2021

home page ramada plaza by wyndham İstanbul city center - Feb 25 2022

web sahibinden satılık kiralık emlak oto alışveriş Ürünleri

plaza sitiada by norberto fuentes goodreads - Jul 13 2023

web plaza sitiada by norberto fuentes 3 45 rating details 11 ratings 1 review get a copy kindle store 14 30 amazon stores kindle edition 696 pages published august 28th

sahibinden satılık kiralık emlak oto alışveriş Ürünleri - Nov 24 2021

plaza sitiada spanish edition kindle edition amazon com - Sep 22 2021

ramada plaza by wyndham istanbul city center - Apr 29 2022

web İstanbul bölgesindeki Şişli plaza yakınındaki indirimli oteller Şimdi rezervasyon yapın ve 75 39 e kadar tasarruf edin 604 tl 39 den başlayan otel

plaza sitiada poesía carena spanish edition abebooks - Aug 02 2022

web sep 12 2023 istanbul tr ramada plaza by wyndham istanbul city center otelinde kahvaltı ve ücretsiz wifi in keyfini çıkarın kendi de ödüle layık görülmüş otel ödül

plaza sitiada by carmen plaza goodreads - Mar 09 2023

web plaza sitiada puede ser leído como un cantar de gesta épico lírico por el que transitamos todos con nuestra común historia a cuestas estamos ante una recreación de rostros

plaza sitiada spanish edition amazon com - Feb 08 2023

web amazon com plaza sitiada spanish edition 9781717898784 fuentes norberto libros libros biografías y memorias arte y literatura disfruta de entrega gratis ofertas

plaza sitiada la idolatría el egocentrismo y el afán de scribd - Apr 10 2023

web plaza sitiada un libro para los enemigos no es más que un vano intento de su autor de insertarse como protagonista de los sucesos que desataron el mal llamado quinquenio

Şişli plaza otelleri İstanbul bölgesi civarındaki en İyi otel - Jan 27 2022

web plaza sitiada proverbio en un acto en verso by miñota enrique publication date 1859 publisher madrid impr de c gonzález collection spandr unclibraries americana

28 plaza sitiada free download borrow and streaming - Sep 03 2022

web translate plaza sitiada see spanish english translations with audio pronunciations examples and word by word explanations

plaza sitiada by norberto fuentes blog biletinial com - Dec 26 2021

web aug 28 2018 plaza sitiada spanish edition kindle edition by fuentes norberto download it once and read it on your kindle device pc phones or tablets use features

conduction heat transfer arpaci solution manual fill and sign - Nov 22 2022

web access free conduction heat transfer arpaci solution manual free click the orange get formen select to begin flattering turn the wizard mode for the top toolbar to obtain more recommendations fill out each fillable field be sure the details you fill include conduction heated transference arpaci find manual is updated press accurate

conduction heat transfer arpaci solution manual fill and sign - Feb 23 2023

web complete conduction heat transfer arpaci resolving handbook online with us legal forms easily fill out pdf blank edit and sign them save or instantly send our final documents

conduction heat transfer arpaci vedat s 1928 free - Sep 01 2023

web conduction heat transfer by arpaci vedat s 1928 publication date 1966 topics heat conduction heat engineering publisher

reading mass addison wesley pub co collection inlibrary printdisabled internetarchivebooks contributor internet archive language english ix 550 p 24 cm access restricted item true

conduction heat transfer arpaci solution manual issuu - May 29 2023

web sep 28 2017 get conduction heat transfer arpaci solution manual pdf file for free from our online library conduction heat transfer arpaci solution manual pdf 72 pages 375 12 kb

conduction heat transfer arpaci solution manual 2022 - Mar 27 2023

web 2 conduction heat transfer arpaci solution manual 2021 06 20 and industry with up to date authoritative information on the use of the finite element method in the study of fluid mechanics and heat transfer

conduction heat transfer arpaci solution manual rar pdf wiki lwn - Mar 15 2022

web heat transfer m necati Özişik 1985 01 01 heat conduction latif m jiji 2009 07 09 this book is designed to provide students with the tools to model analyze and solve a wide range of engineering applications involving conduction heat transfer introduce students to three topics not commonly covered in conduction heat

arpaci conduction heat transfer solution manual copy admin - Sep 20 2022

web 2 arpaci conduction heat transfer solution manual 2023 06 12 methods with content on micro and nanoscale heat transfer with an emphasis on the mathematics and underlying physics

heat transfer arpaci solution manual rar - Apr 15 2022

web heat transfer arpaci solution manual rar 35202671402 heat transfer arpaci solution manual rar 472018111392 908 3694 35 20 26 7 1402 47 20 18 11 1392

get conduction heat transfer arpaci solution manual us legal - Jan 25 2023

web conduction heat transfer arpaci solution manual fill and sign printable template online conduction heat transfer arpaci solution manual get conduction heat transfer arpaci solution manual show details how it works open form follow the instructions easily sign the form with your finger send filled signed form or save epub

conduction heat transfer vedat s arpaci 1966 vdocuments net - Jul 31 2023

web the notation employed for conduction heat transfer terms is as follows heat transfer btu rate of heat transfer q btu hr and rate of heat transfer per unit area q with a subscript or superscript such as q_n q_z or q btu ft² hr

conduction heat transfer arpaci solution manual 2022 - Oct 22 2022

web conduction heat transfer arpaci solution manual downloaded from ftp bydeeeaus com by guest quincy hester heat conduction crc press readers learn the principles of heat transfer using the classic that sets the standard of coverage and organization for all other heat transfer books following the recommendations of the asme

conduction heat transfer arpaci solution manual - Aug 20 2022

web conduction heat transfer arpaci solution manual is available for free download in a number of formats including epub pdf azw mobi and more you can also read the full text online using our ereader anywhere anytime download ebooks through an incredibly easy to use online platform optimised for desktops tablets and mobile similar to

arpaci heat conduction solution manual pdf - Oct 02 2023

web the arpaci heat conduction solution refers to a mathematical solution that describes the conduction of heat in a solid material it is based on the one dimensional heat conduction equation which relates the temperature distribution inside a material to the rate at which heat is conducted through it

convection heat transfer arpaci solution manual copy - Jul 19 2022

web transient heat conduction phase change involving melting and solidification steady and transient forced convection inside ducts free convection over a flat plate hyperbolic heat conduction nonlinear diffusion numerical grid generation techniques and hybrid numerical analytic solutions introduction to heat transfer crc press

solution manual of conduction heat transfer arpaci full pdf - Dec 24 2022

web analytical solution of heat conduction problems in heterogeneous media introducing a more general approach based on the integral transform method has been added in this new edition

conduction heat transfer arpaci solution manual fill and sign - Jun 17 2022

web that leading editor the instantly close at hand giving you sundry useful instruments for filling out a running heat transfers arpaci resolving manual these guidelines together with the editor want guide you through the complete process heated conduction convective heat transfer transport phenomena includes materials processing solution

solution manual of conduction heat transfer arpaci 2023 - May 17 2022

web problems of heat and mass transfer conduction part 1 solution manual for heat conduction david hahn necati Özsisik thermal conductivity stefan boltzmann law heat transfer conduction convection radiation physics heat transfer conduction heat diffusion equation 3 of 26 solution manual for an introduction to fluid

solution manual heat conduction arpaci pdf ams istanbul edu - Apr 27 2023

web conduction heat transfer solution manual arpaci conduction heat transfer solution manual pdf ebooks read arpaci conduction arpaci conduction heat transfer solution manual read free solution manual heat conduction arpaci solution manual heat conduction arpaci as recognized adventure

conduction heat transfer arpaci solution manual pdf - Jun 29 2023

web conduction heat transfer arpaci solution manual a literary masterpiece penned by a renowned author readers attempt a transformative journey unlocking the secrets and untapped potential embedded within each word

solution manual of conduction heat transfer arpaci - Feb 11 2022

web jan 18 2023 comprehending as skillfully as concurrence even more than supplementary will meet the expense of each success next to the pronouncement as with ease as acuteness of this solution manual of conduction heat transfer arpaci can be taken as skillfully as picked to act heat conduction latif m jiji 2009 07 09 this book is