

Servo Valve

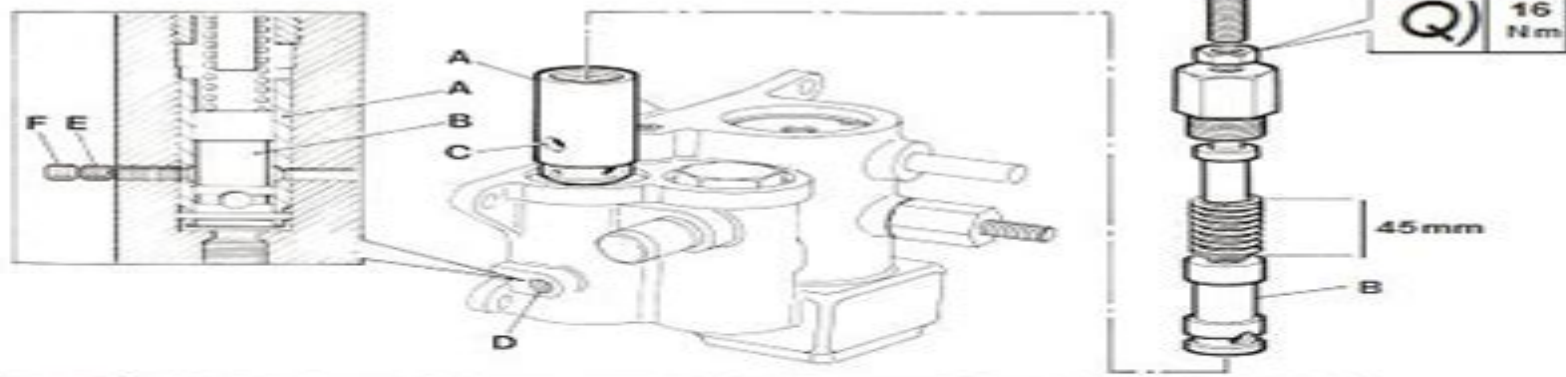

Servo-Valve

- Removal and fitting of sleeve (A) is simplified using a piece of M14 threaded rod.
- eBefore assembly, ensure piston (B) is free from sharp edges and surface damage. Coat piston with Approved Oil. Ensure it slides free by sleeve.
- Ensure chamfered hole (C) in sleeve (A) aligns with grubcrew in hole (D) in housing.
- Secure sleeve (A) using W-point grubcrew (E) and plain grubcrew (F) in order shown.
- ePiston must be inserted, cross drilled and first.
- eApply torque after setting the servo.

- Pour simplifier la dépose et la pose du manchon (A), utiliser une tige filetée M14.
- eAvant le montage, vérifier si le piston (B) est exempt d'arêtes vives et de dégâts de surface. Enduire le piston d'huile homologuée. S'assurer qu'il coulisse librement dans le manchon.
- eAssurer que le trou chanfreiné (C) du manchon (A) s'aligne avec le trou (D) de la vis sans tête dans le logement.
- Fixer le manchon (A) à l'aide de la vis sans tête à pointe W (E) et de la vis sans tête ordinaire (F) dans l'ordre indiqué.
- eLe piston doit être introduit extrême ite percée en premier.
- eSerrer au couple après avoir réglé le servo.

Servoventil

- Der Aus- und Einbau der Hülse (A) wird durch eine Gewindestange M14 vereinfacht.
- eVor dem Zusammenbau sicherstellen, daß Kolben (B) keine scharfen Kanten und Oberflächenschäden aufweist. Kolben mit einem zugelassenen Öl schmieren und sicherstellen, daß er sich frei in der Hülse bewegt.
- Sicherstellen, daß das Loch (C) in der Hülse (A) am Gewindestiftloch (D) im Gehäuse ausgerichtet ist.
- Hülse (A) mit den beiden Gewindestiften (E) in der gezeigten Reihenfolge (F) befestigen.
- Kolben mit dem Ende mit Überbohrung zuerst einbauen.
- Nach der Servoeinstellung festziehen.

Servovalvola

- Per facilitare lo smontaggio ed il montaggio del manicotto (A), usare un pezzo di asse filettato M14.
- Prima dell'assemblaggio accertarsi che il pistone (B) non abbia bordi taglienti o sgraffi superficiali. Spalmare il pistone con olio consigliato. Accertarsi che scorra liberamente nel manicotto.
- Accertarsi che il foro (C) a spigolo smussato nel manicotto (A) sia allineato con il foro della vite senza testa (D) nel corpo della servovalvola.
- Fissare il manicotto (A) usando una vite senza testa appuntita (E) ed una vite senza testa normale (F) nell'ordine indicato.
- Il pistone deve venire inserito con l'estremità col foro trasversale per prima.
- Applicare una coppia torcente dopo aver regolato la servovalvola.

Servo-Kiep

- eVerwijdering en monteren van mof (A) wordt gemakkelijker als een staafje met M14 schroefdraad wordt gebruikt.
- Voordat de opbouw begint moet ervoor worden gezorgd dat zuiger (B) geen scherpe randjes of andere beschadiging van het oppervlak vertoont. Smeer de zuiger in met de goedgekeurde olie. Zorg er voordat de zuiger gemakkelijk in de mof glijdt.
- eZorg ervoor dat gat (C) in de mof (A) precies in lijn komt met stelgrosf gat (D) in het huis.
- Bevestig mof (A) met gepunte stelschroef (E) en gewone stelschroef (F) in de getoonde volgorde.
- De zuiger met het kruisgewijs doorboorde eind naar voren wordt ingestoken.
- Aanzetten met voorgescreven moment na afstellen van de servo.

Servoventil

- Bortagning och montering av hylsan (A) utförs enklast med hjälp av en stycke M14 skruvståf.
- För hopsättning skall manse till att kolben (B) är fri från skarpa kanter och ytskador. Bstryk kolben med godkänd olja. Se till att den glider fritt i hylsan.
- eSe till att det avfasade hålet (C) i hylsan (A) är i linje med stellskruvhålet (D) i huset.
- Fast hylsan (A) med hjälp av W-spetsstallskruv (E) och vanlig stellskruv (F) i ordning enligt bilden.
- Kolven skall sitta in med den tvärborrade änden först.
- Ösa fast efter inställning av servon.

Hydrovane 178 Air Compressor Manual

CH Cherryholmes



Hydrovane 178 Air Compressor Manual:

The Enigmatic Realm of **Hydrovane 178 Air Compressor Manual**: Unleashing the Language is Inner Magic

In a fast-paced digital era where connections and knowledge intertwine, the enigmatic realm of language reveals its inherent magic. Its capacity to stir emotions, ignite contemplation, and catalyze profound transformations is nothing lacking extraordinary. Within the captivating pages of **Hydrovane 178 Air Compressor Manual** a literary masterpiece penned with a renowned author, readers attempt a transformative journey, unlocking the secrets and untapped potential embedded within each word. In this evaluation, we shall explore the book's core themes, assess its distinct writing style, and delve into its lasting affect the hearts and minds of those that partake in its reading experience.

https://staging.conocer.cide.edu/public/detail/Download_PDFS/Encyclopedia%20Of%20The%20Antebellum%20South.pdf

Table of Contents Hydrovane 178 Air Compressor Manual

1. Understanding the eBook Hydrovane 178 Air Compressor Manual
 - The Rise of Digital Reading Hydrovane 178 Air Compressor Manual
 - Advantages of eBooks Over Traditional Books
2. Identifying Hydrovane 178 Air Compressor Manual
 - Exploring Different Genres
 - Considering Fiction vs. Non-Fiction
 - Determining Your Reading Goals
3. Choosing the Right eBook Platform
 - Popular eBook Platforms
 - Features to Look for in an Hydrovane 178 Air Compressor Manual
 - User-Friendly Interface
4. Exploring eBook Recommendations from Hydrovane 178 Air Compressor Manual
 - Personalized Recommendations
 - Hydrovane 178 Air Compressor Manual User Reviews and Ratings
 - Hydrovane 178 Air Compressor Manual and Bestseller Lists

5. Accessing Hydrovane 178 Air Compressor Manual Free and Paid eBooks
 - Hydrovane 178 Air Compressor Manual Public Domain eBooks
 - Hydrovane 178 Air Compressor Manual eBook Subscription Services
 - Hydrovane 178 Air Compressor Manual Budget-Friendly Options
6. Navigating Hydrovane 178 Air Compressor Manual eBook Formats
 - ePub, PDF, MOBI, and More
 - Hydrovane 178 Air Compressor Manual Compatibility with Devices
 - Hydrovane 178 Air Compressor Manual Enhanced eBook Features
7. Enhancing Your Reading Experience
 - Adjustable Fonts and Text Sizes of Hydrovane 178 Air Compressor Manual
 - Highlighting and Note-Taking Hydrovane 178 Air Compressor Manual
 - Interactive Elements Hydrovane 178 Air Compressor Manual
8. Staying Engaged with Hydrovane 178 Air Compressor Manual
 - Joining Online Reading Communities
 - Participating in Virtual Book Clubs
 - Following Authors and Publishers Hydrovane 178 Air Compressor Manual
9. Balancing eBooks and Physical Books Hydrovane 178 Air Compressor Manual
 - Benefits of a Digital Library
 - Creating a Diverse Reading Collection Hydrovane 178 Air Compressor Manual
10. Overcoming Reading Challenges
 - Dealing with Digital Eye Strain
 - Minimizing Distractions
 - Managing Screen Time
11. Cultivating a Reading Routine Hydrovane 178 Air Compressor Manual
 - Setting Reading Goals Hydrovane 178 Air Compressor Manual
 - Carving Out Dedicated Reading Time
12. Sourcing Reliable Information of Hydrovane 178 Air Compressor Manual
 - Fact-Checking eBook Content of Hydrovane 178 Air Compressor Manual
 - Distinguishing Credible Sources
13. Promoting Lifelong Learning

- Utilizing eBooks for Skill Development
- Exploring Educational eBooks

14. Embracing eBook Trends

- Integration of Multimedia Elements
- Interactive and Gamified eBooks

Hydrovane 178 Air Compressor Manual Introduction

In today's digital age, the availability of Hydrovane 178 Air Compressor Manual books and manuals for download has revolutionized the way we access information. Gone are the days of physically flipping through pages and carrying heavy textbooks or manuals. With just a few clicks, we can now access a wealth of knowledge from the comfort of our own homes or on the go. This article will explore the advantages of Hydrovane 178 Air Compressor Manual books and manuals for download, along with some popular platforms that offer these resources. One of the significant advantages of Hydrovane 178 Air Compressor Manual books and manuals for download is the cost-saving aspect. Traditional books and manuals can be costly, especially if you need to purchase several of them for educational or professional purposes. By accessing Hydrovane 178 Air Compressor Manual versions, you eliminate the need to spend money on physical copies. This not only saves you money but also reduces the environmental impact associated with book production and transportation. Furthermore, Hydrovane 178 Air Compressor Manual books and manuals for download are incredibly convenient. With just a computer or smartphone and an internet connection, you can access a vast library of resources on any subject imaginable. Whether you're a student looking for textbooks, a professional seeking industry-specific manuals, or someone interested in self-improvement, these digital resources provide an efficient and accessible means of acquiring knowledge. Moreover, PDF books and manuals offer a range of benefits compared to other digital formats. PDF files are designed to retain their formatting regardless of the device used to open them. This ensures that the content appears exactly as intended by the author, with no loss of formatting or missing graphics. Additionally, PDF files can be easily annotated, bookmarked, and searched for specific terms, making them highly practical for studying or referencing. When it comes to accessing Hydrovane 178 Air Compressor Manual books and manuals, several platforms offer an extensive collection of resources. One such platform is Project Gutenberg, a nonprofit organization that provides over 60,000 free eBooks. These books are primarily in the public domain, meaning they can be freely distributed and downloaded. Project Gutenberg offers a wide range of classic literature, making it an excellent resource for literature enthusiasts. Another popular platform for Hydrovane 178 Air Compressor Manual books and manuals is Open Library. Open Library is an initiative of the Internet Archive, a non-profit organization dedicated to digitizing cultural artifacts and making them accessible to the public. Open Library hosts millions of books, including both public domain works

and contemporary titles. It also allows users to borrow digital copies of certain books for a limited period, similar to a library lending system. Additionally, many universities and educational institutions have their own digital libraries that provide free access to PDF books and manuals. These libraries often offer academic texts, research papers, and technical manuals, making them invaluable resources for students and researchers. Some notable examples include MIT OpenCourseWare, which offers free access to course materials from the Massachusetts Institute of Technology, and the Digital Public Library of America, which provides a vast collection of digitized books and historical documents. In conclusion, Hydrovane 178 Air Compressor Manual books and manuals for download have transformed the way we access information. They provide a cost-effective and convenient means of acquiring knowledge, offering the ability to access a vast library of resources at our fingertips. With platforms like Project Gutenberg, Open Library, and various digital libraries offered by educational institutions, we have access to an ever-expanding collection of books and manuals. Whether for educational, professional, or personal purposes, these digital resources serve as valuable tools for continuous learning and self-improvement. So why not take advantage of the vast world of Hydrovane 178 Air Compressor Manual books and manuals for download and embark on your journey of knowledge?

FAQs About Hydrovane 178 Air Compressor Manual Books

How do I know which eBook platform is the best for me? Finding the best eBook platform depends on your reading preferences and device compatibility. Research different platforms, read user reviews, and explore their features before making a choice. Are free eBooks of good quality? Yes, many reputable platforms offer high-quality free eBooks, including classics and public domain works. However, make sure to verify the source to ensure the eBook credibility. Can I read eBooks without an eReader? Absolutely! Most eBook platforms offer web-based readers or mobile apps that allow you to read eBooks on your computer, tablet, or smartphone. How do I avoid digital eye strain while reading eBooks? To prevent digital eye strain, take regular breaks, adjust the font size and background color, and ensure proper lighting while reading eBooks. What the advantage of interactive eBooks? Interactive eBooks incorporate multimedia elements, quizzes, and activities, enhancing the reader engagement and providing a more immersive learning experience. Hydrovane 178 Air Compressor Manual is one of the best book in our library for free trial. We provide copy of Hydrovane 178 Air Compressor Manual in digital format, so the resources that you find are reliable. There are also many Ebooks of related with Hydrovane 178 Air Compressor Manual. Where to download Hydrovane 178 Air Compressor Manual online for free? Are you looking for Hydrovane 178 Air Compressor Manual PDF? This is definitely going to save you time and cash in something you should think about.

Find Hydrovane 178 Air Compressor Manual :

encyclopedia of the antebellum south

encyclopedia of u. s. foreign relations

encounter with zen

encyclopedia of hurricanes typhoons and cyclones

enciclopedia tu primer libro de consulta

~~encyclopedia of bodywork from acupressure to zone therapy~~

~~encyclopedia of hydrological problems~~

encounters with angels psyche and spirit in the counseling situation a champion

~~encyclopedia of jewish symbols~~

~~encounters in world history sources and themes from the global past~~

encyclopedia of american foreign policy volume i

enchanted oasis

encyclopedia of the global economy

enchancing friends collectible pooh raggedy golliwogg and roosevelt bears

encyclopedia of food and culture. volume 2

Hydrovane 178 Air Compressor Manual :

fährten und spurenkunde google books - Jun 14 2023

web fährten spuren und weitere typische hinterlassenschaften des wildes zu erkennen gehört zum unverzichtbaren rüstzeug des jägers anschaulich und kompakt vermittelt dieser ratgeber das basiswissen zur jagdlichen fährten und spurensuche

fährten und spurenkunde amazon de - May 13 2023

web andreas david ist mit dem kosmos band fährten und spurenkunde ein sehr schönes naturbuch gelungen er beschreibt in seinem buch die fährten spuren und geläufe bzw trittsiegel der wichtigsten heimischen wildtiere schalenwild beutegreifer hasenartige und nagetiere hühnervögel wasservögel und sonstige vögel

fährten und spurenkunde fachbuchjournal - Jan 09 2023

web jul 24 2020 andreas david fährten und spurenkunde stuttgart franckh kosmos 160 s softcover isbn 978 3 440 16524 9 17 99 die 50 wichtigsten wildtiere im steckbrief trittsiegel fährten spuren und geläufe losung gewölle fraßbilder und weitere zeichen Über 200 fotos und zeichnungen zur sicheren bestimmung

Öffentlicher verkehr in istanbul fahrzeuge tickets info - May 01 2022

web nachstehend finden sie alle in istanbul verfügbaren öffentlichen verkehrsmittel metro es gibt das liniennetz die marmaray und die nostalgische tünel u bahn zweitälteste untergrundbahn von europa fähre bosporusfahrt von kontinent zu kontinent goldenes horn prinzeninseln autofähre schnellboote katamaran

fahrten und spurenkunde sam arabtravelers - Aug 04 2022

web fahrten und spurenkunde downloaded from sam arabtravelers com by guest donavan shania library bulletin kosmos fährten spuren und weitere typische hinterlassenschaften des wildes zu erkennen gehört zum unverzichtbaren rüstzeug des jägers anschaulich und kompakt vermittelt dieser ratgeber das basiswissen zur

fahrtenundspurenkunde 2022 dev sfcg - Mar 31 2022

web fährten und spurenkunde und beschreibung sonstiger gewohnheiten zeichen des wildes die dem jäger den standort wechsel oder pasz verraten fährten und spurenkunde sowie beschreibg sonstiger gewohnheiten u

fährten und spurenkunde brandt eiserhardt amazon de bücher - Mar 11 2023

web er beschreibt in seinem buch die fährten spuren und geläufe bzw trittsiegel der wichtigsten heimischen wildtiere schalenwild beutegreifer hasenartige und nagetiere hühnervögel wasservögel und sonstige vögel dazu kommen zeichnungen der läufe sowie fotos der tiere

fährten und spurenkunde kaufen livingactive de - Feb 10 2023

web das buch fährten und spurenkunde vermittelt das basiswissen zur jagdlichen fährten und spurensuche der bewährte begleiter eignet sich auch ideal zur vorbereitung der prüfung Über die kostenlose kosmos plus app kann man sich ergänzend zur theorie die lautäußerungen der wildtiere anhören

fährten und spurenkunde download epub pdf audio - Jul 15 2023

web feb 14 2019 zusammenfassung des buches fährten und spurenkunde fährten spuren en weitere typische hinterlassenschaften des wilds zu herkennen gehört zum unverzichtbaren rüstzeug des jägers anschaulich en kompakt vermittelt dieser ratgeber das basiswissen zur jagdlichen fährten en spurensuche

fährten und spurenkunde buch versandkostenfrei bei weltbild - Nov 07 2022

web bücher bei weltbild jetzt fährten und spurenkunde von andreas david versandkostenfrei online kaufen bei weltbild ihrem bücher spezialisten blitzangebote nur solange der aktions vorrat reicht

fährten und spurenkunde von andreas david buch 978 - Apr 12 2023

web beschreibung fährten spuren und weitere typische hinterlassenschaften des wildes zu erkennen gehört zum unverzichtbaren rüstzeug des jägers anschaulich und kompakt vermittelt dieser ratgeber das basiswissen zur jagdlichen fährten und spurensuche

fährten und spurenkunde kosmos - Aug 16 2023

web 16524 autoren andreas david fährten spuren und weitere typische hinterlassenschaften des wildes zu erkennen gehört zum unverzichtbaren rüstzeug des jähgers anschaulich und kompakt vermittelt dieser ratgeber das basiswissen zur jagdlichen fährten

kosmos buch fährten und spurenkunde bücher dvds - Sep 05 2022

web dec 16 2012 dieser ratgeber vermittelt das basiswissen zur jagdlichen fährten und spurenkunde anschaulich und kompakt und macht ihn zum bewährten begleiter für jäger und jagdscheinanwärter empfohlen von wild und hund bücher sind vom umtausch ausgeschlossen

Öffentliche verkehrsmittel istanbul mein guide für anfänger - Feb 27 2022

web jun 6 2018 jetons an automaten mit der aufschrift jetonmatik die günstigste möglichkeit um von a nach b zu gelangen ist die istanbulkart normalerweise zahlst du für eine einzelfahrt mit einem öffentlichen verkehrsmittel in istanbul 4 lira bei jedem wechsel eines verkehrsmittels zum beispiel metro in straßenbahn musst du noch einmal 4 lira zahlen

Şanlıurfa cesur turizm - Jan 29 2022

web Şanlıurfa cesur turizm koşulsuz müşteri memnuniyeti ilkesinden ödün vermeden yoluna emin adımlarla devam ediyor

fahrtenundspurenkunde dev sfcg - Jun 02 2022

web fährten und spurenkunde kosmos ebooklet fährten zeichen und laute des schalenwildes fährten und spurenkunde fährten und spurenkunde fährten und spurenkunde und beschreibung sonstiger gewohnheiten des wildes die dem jäger den standort wechsel oder paß verraten fährten und spurenkunde und beschreibung

fährten und spurenkunde david andreas amazon de bücher - Dec 08 2022

web des buchklassikers fährten und spurensuche fortgeschrieben Übersichtlich und prägnant stellt der versierte wildbiologe die wichtigsten hinweise auf die wildtiere im wald und in der feldflur vor 50 wildtierarten im steckbrief mit merkmalen und wissenswerten informationen und über 150 fotos und zeichnungen auf 120 seiten was will man mehr

e devlet uçuş bilgileri sorgulama nasıl yapılır e devlet uçuş - Dec 28 2021

web nov 16 2017 35 milyondan fazla vatandaşın kullandığı e devlet sistemine uçuş bilgileri sorgulama hizmeti eklendi peki e devlet uçuş bilgileri sorgulama nasıl yapılır

führerscheine kfz und verkehrsangelegenheiten auswärtiges - Oct 06 2022

web allgemeine hinweise immer mitzuführen sind der pass ggf aufenthaltserlaubnis führerschein kraftfahrzeugschein und die grüne versicherungskarte die grüne karte dient als versicherungsnachweis und erleichtert bei einem unfall die abwicklung auf der versicherungskarte ist angegeben für welche länder versicherungsschutz für ihren

fährten und spurenkunde ebook pdf bücher de - Jul 03 2022

web anschaulich und kompakt vermittelt dieser ratgeber das basiswissen zur jagdlichen fährten und spurensuche ergänzend zur theorie kann man sich lautäußerungen der wildtiere über die kostenlose kosmos plus app anhören

jerry baker s all american lawns 1 776 super solut pdf - Sep 04 2022

web mar 11 2023 merely said the jerry baker s all american lawns 1 776 super solut pdf is universally compatible in the manner of any devices to read

jerry baker s all american lawns 1 776 super solut pdf - Nov 06 2022

web jerry baker s all american lawns 1 776 super solut pdf eventually you will completely discover a extra experience and skill by spending more cash yet jerry baker s all

jerry baker s all american lawns 1 776 super solut pdf pdf - Apr 11 2023

web title jerry baker s all american lawns 1 776 super solut pdf pdf digitalworkgroup skidmore edu created date 9 15 2023 10 46 04 pm

all american lawns 1 776 super solutions to grow repair and - Jun 13 2023

web learn how to grow perfectly green and gorgeous grass without toxic chemicals and expensive lawn care treatments using methods in this compendium of thousands of

jerry baker s all american lawns 1 776 super solut pdf - Jul 02 2022

web mar 13 2023 as this jerry baker s all american lawns 1 776 super solut pdf it ends occurring being one of the favored ebook jerry baker s all american lawns 1 776

jerry baker s all american lawns 1 776 super solut copy - Dec 27 2021

web this jerry baker s all american lawns 1 776 super solut as one of the most working sellers here will certainly be accompanied by the best options to review national

jerry baker s all american lawns 1 776 super solut - Jan 28 2022

web revised german edition of 1949 makes schweidler s work available in english for the first time in a meticulously edited and annotated critical edition the editor s introduction

jerry baker s all american lawns 1 776 super solut copy - Mar 30 2022

web mar 3 2023 and install jerry baker s all american lawns 1 776 super solut fittingly simple jerry baker s back to nature almanac jerry baker 1972 a unique encyclopedia

jerry baker s all american lawns 1 776 super solut download - Aug 03 2022

web jan 24 2023 jerry baker s all american lawns 1 776 super solut is available in our book collection an online access to it is set as public so you can get it instantly our

jerry baker s all american lawns 1 776 super solut pdf - Jun 01 2022

web jun 26 2023 1 jerry baker s all american lawns 1 776 super solut pdf recognizing the pretentiousness ways to get this books jerry baker s all american lawns 1 776

jerry baker good gardening ser jerry baker s all american - May 12 2023

web find many great new used options and get the best deals for jerry baker good gardening ser jerry baker s all american lawns 1 776 super solutions to grow

jerry baker s all american lawns 1 776 super solut pdf 2023 - Feb 09 2023

web apr 18 2023 those all we allow jerry baker s all american lawns 1 776 super solut pdf and numerous books collections from fictions to scientific research in any way in the

jerrybakersallamericanlawns1776supersolut pdf - Nov 25 2021

web jerrybakersallamericanlawns1776supersolut 1 jerrybakersallamericanlawns1776supersolut

jerry baker s all american lawns 1 776 super solut pdf - Apr 30 2022

web enormously offer it is not in relation to the costs its virtually what you habit currently this jerry baker s all american lawns 1 776 super solut pdf as one of the most

jerry baker s all american lawns 1 776 super solut pdf 2023 - Oct 05 2022

web jun 3 2023 jerry baker s all american lawns 1 776 super solut pdf is available in our digital library an online access to it is set as public so you can get it instantly our book

lawler s law tracker first to 100 wins - Oct 25 2021

web since the 1996 97 season lawler s law has been correct 92 04 of the time last law breaker heat the miami heat beat the celtics on may 19 2023 despite trailing 100

jerry baker s all american lawns 1 776 super solutions to - Jul 14 2023

web buy jerry baker s all american lawns 1 776 super solutions to grow repair and maintain the best lawn in the land by jerry baker online at alibris we have new and

jerry baker s all american lawns 1 776 super solutions to - Aug 15 2023

web jerry baker s all american lawns 1 776 super solutions to grow repair and maintain the best lawn in the land

jerry baker s all american lawns 1 776 super solut pdf 2023 - Mar 10 2023

web jerry baker s all american lawns 1 776 super solut pdf upload suny i williamson 2 2 downloaded from support ortax org on september 2 2023 by suny i williamson each

jerry baker s all american lawns 1 776 super solut pdf pdf - Feb 26 2022

web mar 12 2023 quirk to acquire those all we pay for jerry baker s all american lawns 1 776 super solut pdf and numerous book collections from fictions to scientific research

jerry baker s all american lawns 1 776 super solut pdf pdf - Dec 07 2022

web may 29 2023 1 jerry baker s all american lawns 1 776 super solut pdf right here we have countless books jerry baker s all american lawns 1 776 super solut pdf

jerry baker s all american lawns 1 776 super solut pdf george - Jan 08 2023

web 1 jerry baker s all american lawns 1 776 super solut pdf this is likewise one of the factors by obtaining the soft documents of this jerry baker s all american lawns 1

test bank for marketing international edition 16th edition by hult - Dec 06 2022

web oct 22 2022 test bank for marketing management 16e 16th edition by philip kotler alexander chernev isbn 13 7158 full chapters test bank included part 1

test bank for international marketing 16th edition by cateora issuu - Sep 22 2021

test bank international marketing 16th edition by philip cateora - Apr 10 2023

web international marketing 16th edition cateora test bank download free download as pdf file pdf text file txt or read online for free test bank

test bank for marketing management 16th edition by philip - Oct 04 2022

web test bank for marketing international edition 16th edition by g tomas isbn 13 9781133526148 isbn10 1133526144 chapter 11 strategic product management

international marketing 16th edition cateora test bank - Nov 24 2021

web feb 11 2018 test bank for international marketing 16th edition by cateora test bank for international marketing 16th edition by cateora full clear download no error

international marketing 16th edition cateora test bank - Aug 14 2023

web international marketing 16th edition cateora test bank free download as pdf file pdf text file txt or read online for free test bank

test bank for international marketing 16th edition - Sep 03 2022

web marketing international edition 16th edition by g tomas test bank 35 00 25 00 this is not a textbook please check the free sample before buying edition 16th

ch7 test bank principles of marketing 16e kotler studocu - Jan 27 2022

web test bank comes in a pdf or word format and available for download only international marketing 16th edition cateora cateora test bank with answers of this test bank

marketing international edition 16th edition by g tomas - Jul 01 2022

web marketing international edition 16th edition by g tomas test bnak chapter 9 digital marketing and social media essay 1 describe the opportunities that have evolved in

test bank for international marketing 16th edition cateora issuu - Dec 26 2021

web may 11 2018 full file at testbankuniv eu international marketing 17th edition cateora test bank 6 a nation s balance of payments statement records all financial

international marketing 16th edition cateora test bank 1 - Jul 13 2023

web international marketing 16th edition cateora test bank 1 free download as pdf file pdf text file txt or read online for free test bank

downloadable test bank for international marketing 17th edition - Nov 05 2022

web test bank for international marketing 16th edition 35 99 19 99 a complete test bank for international marketing 16th edition authors philip r cateora university

marketing international edition 16th edition by g tomas test bnak - Apr 29 2022

web test bank solutions manual ebook connect assignments and learn smart quizzes for international marketing 18th edition by philip cateora isbn10 1259712354

marketing international edition 16th edition by g tomas test bnak - Aug 02 2022

web international marketing middle east 16th edition by cateora test bank chapter 08 developing a global vision through marketing research true false questions 1

test bank for international marketing 16th edition by - May 11 2023

web aug 28 2018 test bank international marketing 16th edition by philip cateora textbook exams table of contents chapter 1 the scope and challenge of

test bank for international marketing 16th edition by cateora - Mar 29 2022

web testbanktube product test bank principles marketing 16th edition kotler consists of evaluating each market segment s attractiveness and selecting one or more segments to

marketing international edition 16th edition by g tomas - Jan 07 2023

web downloadable test bank for international marketing 17th edition cateora tbchap001 1 chapter 01 the scope and challenge of international marketing true false

international marketing 17th edition cateora test bank issuu - Oct 24 2021

test bank solutions manual for international marketing 18th - Feb 25 2022

web may 30 2018 full file at testbankscafe eu test bank for international marketing 16th edition cateora

international marketing middle east 16th edition by cateora test - May 31 2022

web instantly download test bank for international marketing 16th edition by cateora from trusted source provides a thousand solutions manual and test bank questions digital

test bank and solutions for marketing 16th edition by roger - Jun 12 2023

web solutions manual ebook test bank for marketing 16th edition by roger kerin steven hartley 1264121326 9781264121328 and connect assignments quizzes

test bank solutions marketing management 16th edition - Feb 08 2023

web complete downloadable test bank for marketing international edition 16th edition by hult instructor resource information title marketing international

international marketing 16th edition cateora test bank download - Mar 09 2023

web test bank for marketing international edition 16th edition by g tomas duration unlimited downloads delivery instant download