

1

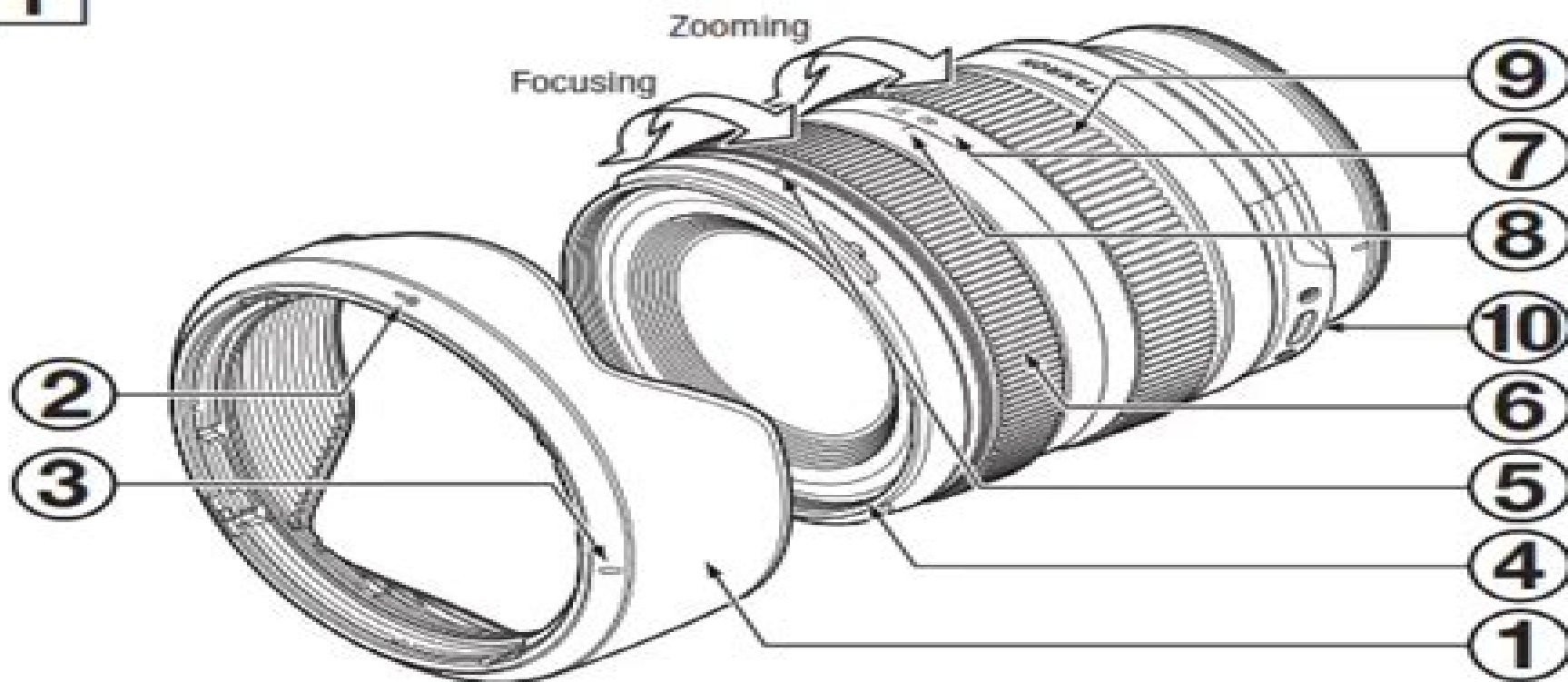

Sony

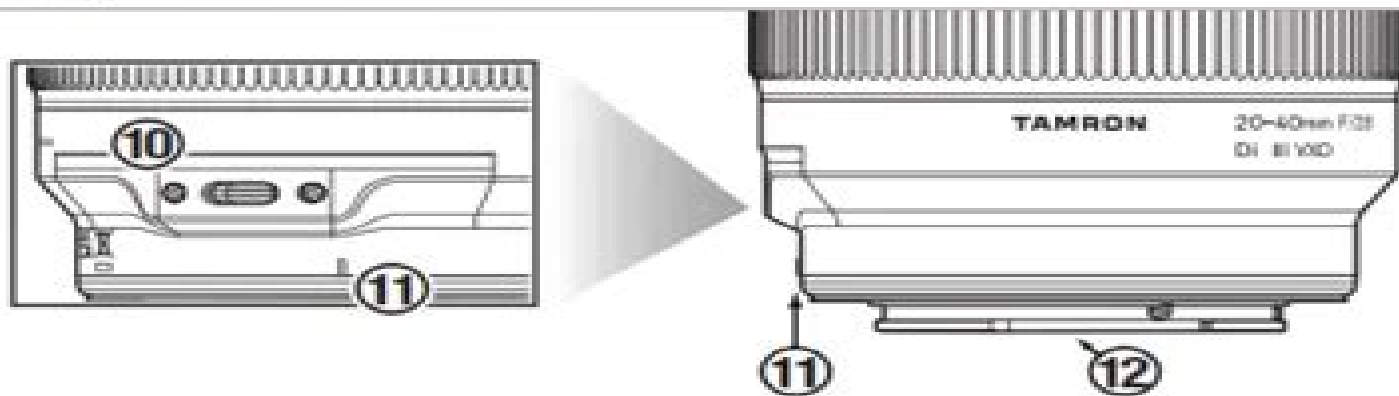

# Ge Camera Lens User Manual

**Judd E. Hollander**



## **Ge Camera Lens User Manual:**

**Operator's Manual, Camera Set, Still Picture KS-19A3**, 1990 Handbook of Supersonic Aerodynamics R. J. Volluz, 1961 **Critical Metals Handbook** Gus Gunn, 2014-03-03 Mankind is using a greater variety of metals in greater quantities than ever before As a result there is increasing global concern over the long term availability of secure and adequate supplies of the metals needed by society Critical metals which are those of growing economic importance that might be susceptible to future scarcity are a particular worry For many of these we have little information on how they are concentrated in the Earth's crust how to extract them from their ores and how to use recycle and dispose of them effectively and safely Published with the British Geological Survey the Critical Metals Handbook brings together a wealth of knowledge on critical metals and provides a foundation for improving the future security and sustainability of critical metal supplies Written by international experts it provides a unique source of authoritative information on diverse aspects of the critical metals including geology deposits processing applications recycling environmental issues and markets It is aimed at a broad non specialist audience including professionals and academics working in the exploration and mining sectors in mining finance and investment and in mineral processing and manufacturing It will also be a valuable reference for policy makers concerned with resource management land use planning eco efficiency recycling and related fields *Handbook of 3D Machine Vision* Song Zhang, 2013-03-15 With the ongoing release of 3D movies and the emergence of 3D TVs 3D imaging technologies have penetrated our daily lives Yet choosing from the numerous 3D vision methods available can be frustrating for scientists and engineers especially without a comprehensive resource to consult Filling this gap *Handbook of 3D Machine Vision Optical Metrology and Imaging* gives an extensive in depth look at the most popular 3D imaging techniques It focuses on noninvasive noncontact optical methods optical metrology and imaging The handbook begins with the well studied method of stereo vision and explains how random speckle patterns or space time varying patterns substantially improve the results of stereo vision It then discusses stereo particle image velocimetry as a major experimental means in fluid dynamics the robust and easy to implement structured light technique for computer science applications digital holography for performing micro to nanoscale measurements and grating interferometry and fringe projection techniques for precisely measuring dynamically deformable natural objects The book goes on to describe techniques that do not require triangulation to recover a 3D shape including time of flight techniques and uniaxial 3D shape measurement as well as 3D measurement techniques that are not restricted to surface capture such as 3D ultrasound optical coherence tomography and 3D endoscopy The book also explores how novel 3D imaging techniques are being applied in the promising field of biometrics which may prove essential to security and public safety Written by key players in the field and inventors of important imaging technologies this authoritative state of the art handbook helps you understand the core of 3D imaging technology and choose the proper 3D imaging technique for your needs For each technique the book provides its mathematical foundations summarizes its successful applications and

discusses its limitations *Handbook of Supersonic Aerodynamics* Johns Hopkins University. Applied Physics Laboratory, 1961 *Leica Instructions for the Use of the Leica Camera Models M5, CL, Leicaflex, Leicaflex SL & SL2* Ernst Leitz, 2006-11-15 This is a reprint of the series of Leica Instruction Books as issued by E Leitz from Wetzlar It is applicable to all English Language markets This title includes many reflex accessories e g motor drives focusing Bellows R Elpro lenses and extension tubes *How to Buy and Use Home Video Equipment* Marjorie Costello, Michael Heiss, 1989-10-16

**Modern Photography** ,1988 **Boys' Life** ,1968-11 Boys Life is the official youth magazine for the Boy Scouts of America Published since 1911 it contains a proven mix of news nature sports history fiction science comics and Scouting

**American Photography** ,1928 **Non Invasive Diagnostic Techniques in Clinical Dermatology** Enzo Berardesca, Howard I. Maibach, Klaus-Peter Wilhelm, 2013-12-02 This book is a comprehensive but compact guide to the latest technical and technological developments in the growing field of non invasive diagnosis in clinical dermatology Information is provided on the practical and technical characteristics of a wide range of equipment and methods for in vivo measurements that aid in the investigation of skin function the evaluation of topically applied products and the monitoring of skin disease Individual sections are devoted to imaging techniques skin analysis superficial skin analysis skin mechanics water and stratum corneum hydration and erythema and blood flow All of the authors are experts in the field with detailed knowledge of the techniques they describe Non Invasive Diagnostic Techniques in Clinical Dermatology will be of value for all dermatologists whether they are engaged in delivering patient care or in research programs for cosmetic scientists and for biologists involved in skin research and product assessment **Proteomics in Practice** Reiner Westermeier, Tom Naven, Hans-Rudolf Höpker, 2008-09-08 Still the only concise practical guide to laboratory experiments in proteomics this new edition now also covers DIGE technology and liquid chromatography while the troubleshooting section has been considerably extended Adopting a practical approach the authors present the relevant techniques and explain the route to successful experimental design and optimal method selection They cover such electrophoretic techniques as isoelectric focusing SDS page 2 D page and DIGE as well as liquid chromatography techniques such as ion exchange affinity chromatography and reversed phase HPLC Mass spectrometric techniques include MALDI ESI and FT ICR Generously illustrated partly in color the book also features updates of protocols as well as animations illustrating crucial methodological steps on a companion website Official Gazette of the United States Patent and Trademark Office ,1993 **Boys' Life** ,1969-02 Boys Life is the official youth magazine for the Boy Scouts of America Published since 1911 it contains a proven mix of news nature sports history fiction science comics and Scouting *Popular Photography - ND* ,1947-11 *Popular Photography* ,1984-01 *Popular Photography* ,1983-05 **Boys' Life** ,1969-11 Boys Life is the official youth magazine for the Boy Scouts of America Published since 1911 it contains a proven mix of news nature sports history fiction science comics and Scouting *The Informatics Handbook* S.A. Fist, 2012-12-06 This is not a dictionary and nor is it an encyclopedia It is a

reference and compendium of useful information about the converging worlds of computers communications telecommunications and broadcasting You could refer to it as a guide for the Information Super Highway but this would be pretentious It aims to cover most of the more important terms and concepts in the developing discipline of Informatics which in my definition includes the major converging technologies and the associated social and cultural issues Unlike a dictionary this handbook makes no attempt to be prescriptive in its definitions Many of the words we use today in computing and communications only vaguely reflect their originations And with such rapid change older terms are often taken twisted inverted and mangled to the point where any attempt by me to lay down laws of meaning would be meaningless The information here is descriptive I am concerned with usage only This book therefore contains keywords and explanations which have been culled from the current literature from technical magazines newspapers the Internet forums etc This is the living language as it is being used today not a historical artifact of 1950s computer science Popular Photography - ND,1948-05

Embark on a breathtaking journey through nature and adventure with Explore with is mesmerizing ebook, Witness the Wonders in **Ge Camera Lens User Manual** . This immersive experience, available for download in a PDF format ( \*), transports you to the heart of natural marvels and thrilling escapades. Download now and let the adventure begin!

[https://staging.conocer.cide.edu/data/book-search/index.jsp/manual\\_for\\_chevrolet\\_ls1\\_350\\_engine.pdf](https://staging.conocer.cide.edu/data/book-search/index.jsp/manual_for_chevrolet_ls1_350_engine.pdf)

## **Table of Contents Ge Camera Lens User Manual**

1. Understanding the eBook Ge Camera Lens User Manual
  - The Rise of Digital Reading Ge Camera Lens User Manual
  - Advantages of eBooks Over Traditional Books
2. Identifying Ge Camera Lens User Manual
  - Exploring Different Genres
  - Considering Fiction vs. Non-Fiction
  - Determining Your Reading Goals
3. Choosing the Right eBook Platform
  - Popular eBook Platforms
  - Features to Look for in an Ge Camera Lens User Manual
  - User-Friendly Interface
4. Exploring eBook Recommendations from Ge Camera Lens User Manual
  - Personalized Recommendations
  - Ge Camera Lens User Manual User Reviews and Ratings
  - Ge Camera Lens User Manual and Bestseller Lists
5. Accessing Ge Camera Lens User Manual Free and Paid eBooks
  - Ge Camera Lens User Manual Public Domain eBooks
  - Ge Camera Lens User Manual eBook Subscription Services
  - Ge Camera Lens User Manual Budget-Friendly Options
6. Navigating Ge Camera Lens User Manual eBook Formats

- ePub, PDF, MOBI, and More
- Ge Camera Lens User Manual Compatibility with Devices
- Ge Camera Lens User Manual Enhanced eBook Features
- 7. Enhancing Your Reading Experience
  - Adjustable Fonts and Text Sizes of Ge Camera Lens User Manual
  - Highlighting and Note-Taking Ge Camera Lens User Manual
  - Interactive Elements Ge Camera Lens User Manual
- 8. Staying Engaged with Ge Camera Lens User Manual
  - Joining Online Reading Communities
  - Participating in Virtual Book Clubs
  - Following Authors and Publishers Ge Camera Lens User Manual
- 9. Balancing eBooks and Physical Books Ge Camera Lens User Manual
  - Benefits of a Digital Library
  - Creating a Diverse Reading Collection Ge Camera Lens User Manual
- 10. Overcoming Reading Challenges
  - Dealing with Digital Eye Strain
  - Minimizing Distractions
  - Managing Screen Time
- 11. Cultivating a Reading Routine Ge Camera Lens User Manual
  - Setting Reading Goals Ge Camera Lens User Manual
  - Carving Out Dedicated Reading Time
- 12. Sourcing Reliable Information of Ge Camera Lens User Manual
  - Fact-Checking eBook Content of Ge Camera Lens User Manual
  - Distinguishing Credible Sources
- 13. Promoting Lifelong Learning
  - Utilizing eBooks for Skill Development
  - Exploring Educational eBooks
- 14. Embracing eBook Trends
  - Integration of Multimedia Elements
  - Interactive and Gamified eBooks

---

## Ge Camera Lens User Manual Introduction

In the digital age, access to information has become easier than ever before. The ability to download Ge Camera Lens User Manual has revolutionized the way we consume written content. Whether you are a student looking for course material, an avid reader searching for your next favorite book, or a professional seeking research papers, the option to download Ge Camera Lens User Manual has opened up a world of possibilities. Downloading Ge Camera Lens User Manual provides numerous advantages over physical copies of books and documents. Firstly, it is incredibly convenient. Gone are the days of carrying around heavy textbooks or bulky folders filled with papers. With the click of a button, you can gain immediate access to valuable resources on any device. This convenience allows for efficient studying, researching, and reading on the go. Moreover, the cost-effective nature of downloading Ge Camera Lens User Manual has democratized knowledge. Traditional books and academic journals can be expensive, making it difficult for individuals with limited financial resources to access information. By offering free PDF downloads, publishers and authors are enabling a wider audience to benefit from their work. This inclusivity promotes equal opportunities for learning and personal growth. There are numerous websites and platforms where individuals can download Ge Camera Lens User Manual. These websites range from academic databases offering research papers and journals to online libraries with an expansive collection of books from various genres. Many authors and publishers also upload their work to specific websites, granting readers access to their content without any charge. These platforms not only provide access to existing literature but also serve as an excellent platform for undiscovered authors to share their work with the world. However, it is essential to be cautious while downloading Ge Camera Lens User Manual. Some websites may offer pirated or illegally obtained copies of copyrighted material. Engaging in such activities not only violates copyright laws but also undermines the efforts of authors, publishers, and researchers. To ensure ethical downloading, it is advisable to utilize reputable websites that prioritize the legal distribution of content. When downloading Ge Camera Lens User Manual, users should also consider the potential security risks associated with online platforms. Malicious actors may exploit vulnerabilities in unprotected websites to distribute malware or steal personal information. To protect themselves, individuals should ensure their devices have reliable antivirus software installed and validate the legitimacy of the websites they are downloading from. In conclusion, the ability to download Ge Camera Lens User Manual has transformed the way we access information. With the convenience, cost-effectiveness, and accessibility it offers, free PDF downloads have become a popular choice for students, researchers, and book lovers worldwide. However, it is crucial to engage in ethical downloading practices and prioritize personal security when utilizing online platforms. By doing so, individuals can make the most of the vast array of free PDF resources available and embark on a journey of continuous learning and intellectual growth.



---

## FAQs About Ge Camera Lens User Manual Books

**What is a Ge Camera Lens User Manual PDF?** A PDF (Portable Document Format) is a file format developed by Adobe that preserves the layout and formatting of a document, regardless of the software, hardware, or operating system used to view or print it. **How do I create a Ge Camera Lens User Manual PDF?** There are several ways to create a PDF: Use software like Adobe Acrobat, Microsoft Word, or Google Docs, which often have built-in PDF creation tools. **Print to PDF:** Many applications and operating systems have a "Print to PDF" option that allows you to save a document as a PDF file instead of printing it on paper. **Online converters:** There are various online tools that can convert different file types to PDF. **How do I edit a Ge Camera Lens User Manual PDF?** Editing a PDF can be done with software like Adobe Acrobat, which allows direct editing of text, images, and other elements within the PDF. Some free tools, like PDFescape or Smallpdf, also offer basic editing capabilities. **How do I convert a Ge Camera Lens User Manual PDF to another file format?** There are multiple ways to convert a PDF to another format: Use online converters like Smallpdf, Zamzar, or Adobe Acrobat's export feature to convert PDFs to formats like Word, Excel, JPEG, etc. Software like Adobe Acrobat, Microsoft Word, or other PDF editors may have options to export or save PDFs in different formats. **How do I password-protect a Ge Camera Lens User Manual PDF?** Most PDF editing software allows you to add password protection. In Adobe Acrobat, for instance, you can go to "File" -> "Properties" -> "Security" to set a password to restrict access or editing capabilities. **Are there any free alternatives to Adobe Acrobat for working with PDFs?** Yes, there are many free alternatives for working with PDFs, such as: LibreOffice: Offers PDF editing features. PDFsam: Allows splitting, merging, and editing PDFs. Foxit Reader: Provides basic PDF viewing and editing capabilities. **How do I compress a PDF file?** You can use online tools like Smallpdf, ILovePDF, or desktop software like Adobe Acrobat to compress PDF files without significant quality loss. Compression reduces the file size, making it easier to share and download. **Can I fill out forms in a PDF file?** Yes, most PDF viewers/editors like Adobe Acrobat, Preview (on Mac), or various online tools allow you to fill out forms in PDF files by selecting text fields and entering information. **Are there any restrictions when working with PDFs?** Some PDFs might have restrictions set by their creator, such as password protection, editing restrictions, or print restrictions. Breaking these restrictions might require specific software or tools, which may or may not be legal depending on the circumstances and local laws.

### Find Ge Camera Lens User Manual :

~~manual for chevrolet ls1 350 engine~~

**manual for starrett hb350**

*manual for gzone commando*

**manual for keebler personal pie maker**

manual for hyundai tucson

manual for polaris 7sports twin

manual for jvc tv

manual for carrier remote control

**manual for gmc canyon 2005 down load**

manual for gin poles

**manual for palamides**

manual for citroen xsara picasso

**manual for singer sewing machine 1120**

manual for kawasaki 250x jetski

manual for case 570lxt tractor

**Ge Camera Lens User Manual :**

*florida virtual school life management skills answers pdf* - Sep 27 2022

web aug 20 2023 florida virtual school life management skills answers 1 8 downloaded from uniport edu ng on august 20 2023 by guest florida virtual school life

**flvs life management skills answers answers for 2023 exams** - Jul 06 2023

web 3064 flvs life management skills answers added by request 3494 kb s 9807 life management skills module 1 2 flashcards quizlet

**florida virtual school life management skills answers pdf** - Dec 31 2022

web sep 11 2023 florida virtual school life management skills answers 1 7 downloaded from uniport edu ng on september 11 2023 by guest florida virtual school life

florida virtual school life management skills answers copy - Jul 26 2022

web mar 1 2023 florida virtual school life management skills answers as recognized adventure as skillfully as experience virtually lesson amusement as without difficulty as

**life management skills teacher s guide and student workbook** - Nov 29 2022

web the life management skills pass parallel alternative strategies for students teacher s guide presents 10 units concerned with various life management skills including three

**florida virtual school life management skills answers** - Dec 19 2021

web this florida virtual school life management skills answers as one of the most keen sellers here will no question be along with the best options to review project

[7 high school survival tips from florida virtual school graduates](#) - Jun 24 2022

web aug 2 2022 survival tip 3 get involved get involved in clubs and classes as much as possible go to live lessons interacting with teachers and fellow classmates is really

*florida virtual school life management skills answers john* - Apr 22 2022

web jul 15 2023 we have the funds for florida virtual school life management skills answers and numerous books collections from fictions to scientific research in any way

**life management skills module 1 2 flashcards quizlet** - Oct 09 2023

web flvs life management skills module 1 2 review learn with flashcards games and more for free

**finding success with florida virtual school the virtual voice** - Mar 22 2022

web jul 25 2020 emari was enrolled in florida virtual school from 7th through 11th grade all of her end of course eoc assessments that were required for her to be eligible to

**life management skills module 1 2 flashcards quizlet** - Feb 18 2022

web flvs life management skills module 1 2 review learn with flashcards games and more for free

*life management skills flvs florida virtual school* - Feb 01 2023

web ready to start learn how to enroll in flvs flex learn how to enroll in flvs full time courses subject to availability pursuant to s 1002 20 f s

[florida virtual school life management skills answers pdf](#) - Nov 17 2021

web aug 18 2023 florida virtual school life management skills answers 2 8 downloaded from uniport edu ng on august 18 2023 by guest their emotions by understanding what

[florida virtual school life management skills answers pdf](#) - Aug 27 2022

web jul 14 2023 florida virtual school life management skills answers 1 8 downloaded from uniport edu ng on july 14 2023 by guest florida virtual school life management

**life management skills florida virtual high school** - Apr 03 2023

web discover the best homework help resource for life management skills at florida virtual high school find life management skills study guides notes and

*life management skills the virtual voice flvs* - Jan 20 2022

web sep 5 2017 life management skills five flvs electives that teach life skills by guest blogger on september 5th 2017

**five flvs electives that teach life skills the virtual voice** - Mar 02 2023

web life management skills this class teaches how to deal with real issues that impact your everyday life such as nutrition substance abuse stress and health some of the

**35 florida virtual school interview questions answers** - May 24 2022

web dec 3 2021 35 florida virtual school interview questions answers table of contents behavioral 1 tell me about the last time you received and responded to

**health v14 life management skills flvs course hero** - Sep 08 2023

web access study documents get answers to your study questions and connect with real tutors for health v14 life management skills at florida virtual school

**life management skills 1 05 course hero** - May 04 2023

web access study documents get answers to your study questions and connect with real tutors for life management skills 1 05 constructing your health decisions at florida

*life management skills florida virtual high school* - Jun 05 2023

web discover the best homework help resource for life management skills at florida virtual high school find life management skills study guides notes and practice

*florida virtual school life management skills answers 2022* - Oct 29 2022

web florida virtual school life management skills answers 1 florida virtual school life management skills answers raising the bar the virtual high school issues of

health 1 life management skills florida virtual school - Aug 07 2023

web access study documents get answers to your study questions and connect with real tutors for health 1 life management skills at florida virtual school

**how to left hand practice on harmonium and keyboard left youtube** - Oct 26 2022

web sep 29 2020 how to left hand practice on harmonium and keyboard left hand practice on harmonium by lokendra chaudhary chaudharybrothers lokendrachaughary

*047 left hand literacy skills your left hand is missing* - Jun 21 2022

web apr 11 2022 our right hand spins out the tune but our left hand provides the harmonic support and rhythmic stability that make that tune intelligible in short our left hand has a specialized vocabulary certain techniques and patterns that are different from those our right hand usually plays

harmonic devices here are three things to do with your left hand - Sep 05 2023

web one of the challenges up and coming piano players face is what to do with the left hand the list of ideas for the left hand is inexhaustible ranging from the use of notes c for the c major seventh chord to the use of intervals c major seventh interval

for the c major seventh chord

**practicing chopin ballade 1 piano fingering harmony left youtube** - Oct 06 2023

web 48 subscribers subscribe 208 views 5 months ago this is a two hour piano practice session of chopin ballade 1 in g minor for piano this piece is on the trinity ltcl list so a nice challenge after

how to practice hanon exercises piano articles weekly - Dec 28 2022

web to better hear inaccuracies and issues related to the left hand weaker fingers uneven tone unnecessary accents one of the most useful exercises is to play hanon swapping the right and left hand this allows you to hear the left hand a lot better it is also one of the ultimate ways to detect problems with synchronisation between hands not

**harmony left hand practicing cdn writermag** - Aug 24 2022

web harmony left hand practicing a course of instruction of theory practice of magic magical evocation magical words twentieth century music theory and practice performance practice the language and materials of music third edition etude music magazine multimedia modeling lords of the left hand path the etude the musical

*technique how to train the left hand piano music practice* - Feb 27 2023

web to train the left hand you need a lot of practice things that can improve your left hand s strength while playing include trying piano exercises that train the left hand so that it feels stronger while playing or consulting with a piano teacher or someone who is experienced in playing the piano and ask them how they train their left hand

**improving your left hand technique practising the piano** - Aug 04 2023

web a secure left hand technique is essential for pianistic development and special exercises and studies can be very beneficial we listen only to our left hand which is now responsible all by itself for maintaining the pulse and playing rhythmically and

*left hand exercises piano beginner keyboards* - Jun 02 2023

web dec 3 2022 practice the same section of music with both hands this left hand piano exercise applies to individuals who do not have problems reading left hand notation thus practice it in the left as well whatever you learn in the right hand the exercise works well with studies scales arpeggios and short exercises

**harmony left hand practicing protese odontocompany** - Feb 15 2022

web you get expert information on left and right hand piano techniques playing scales melodies harmonies and chords and practicing to improve your technique everything you need to start

**harmony left hand practicing protese odontocompany com** - Jul 23 2022

web 4 harmony left hand practicing 2022 07 22 to present an exercise program that is a celebration of life itself more than a standard guidebook dr mao s harmony tai chi focuses on awakening the spirit while strengthening the body ideal for both

beginners and those looking to deepen their tai chi practice dr mao s harmony tai chi fully

**5 tips on arranging and improvising a left hand for harp** - May 21 2022

web if the right hand is fast and complicated simplify the left hand when your right hand is doing a lot it doesn t need a lot of support from left hand maybe just an occasional chord a complicated melody such as this the banks of spey only needs a chord every so often in the left hand

download solutions harmony left hand practicing - Apr 19 2022

web harmony left hand practicing left handed handwriting practice paper oct 23 2022 handwriting practice paper features spine on the right side for left handers to comfortably practice writing 120 pages of lined handwriting paper the wide midline dashes and thick baseline helps handwriting practice easier compatible with d nealian zaner bloser and

**left hand typing practice to effectively train your fingers** - Sep 24 2022

web left hand typing practice left hand typing practice is required to improve your overall typing speed as you keep practicing all keys soon you might discover that your right hand is typing faster than your left hand if you analyze the fingers to be used on each character on the keyboard you would find that more keys need to be typed by your

**de stupefy your left hand pianote** - Mar 31 2023

web jan 13 2023 de stupefy your left hand for many people our left hands are weaker and while the right hand typically carries the melody on the piano piano wouldn t be the same without the left hand providing beautiful arpeggios and accompaniment patterns your left hand deserves more love so check out the de stupefy your left

*using left hand on piano music practice theory stack exchange* - May 01 2023

web in addition to the bass line the left hand can add more voicings or harmonies much like the right hand often plays more notes than just the melody these middle voicings what you might call alto and tenor are crucial for certain voice leadings

harmony left hand practicing store kawan equipment - Mar 19 2022

web 2 harmony left hand practicing 2020 01 02 learning to dance is fun and it is easy in a sense it is like learning a new language a language of rhythm grace and harmony dancing develops grace and poise timing and balance men take pride in their ability to lead their partners with assurance and poise girls enjoy the ability to follow

left hand piano exercises to help your hands cooperate - Jul 03 2023

web may 21 2022 practice a two octave scale play the melody line with your left hand play slowly play the left hand with a stronger dynamic try shadow playing in the left hand faqs why won t my left hand cooperate it can be frustrating that the left hand can t seem to fall into the groove with the right

*how to improve left hand piano playing simply* - Jan 29 2023

web may 26 2022 give your left hand more work if your right hand is your dominant hand you use it more daily making it

stronger and reinforcing the connection between your brain and your fingers this benefits your right hand piano playing to improve your left hand playing be intentional in doing the following with your left hand from now on

**harmony left hand practicing 50storiesfortomorrow ilfu com** - Nov 26 2022

web harmony left hand practicing 2 downloaded from 50storiesfortomorrow ilfu com on 2021 12 29 by guest introductory course for the more advanced player it becomes a handy reference to keep around for periodic refreshers topics include finding the perfect keyboard and caring for your piano the intricacies of reading music including notes

*primary 5 science exam test papers sg exam free test papers* - Jun 18 2023

web 2022 p5 science semestral assessment 2 singapore chinese girls pdf 2022 p5 science semestral assessment 2 tao nan pdf 2022 p5 science weighted assessment 1 acs junior pdf

pearson education science answers 145 download only - Apr 16 2023

web pearson education science answers 145 res principles of health science answer key may 27 2022 principles of health science answer key assignments in junior science jul 29 2022 each book in this series provides a selection of work sheets covering one or two major topics the work sheets are generally self contained supplying the

fillable online cachristie pearson education science answers 145 - May 17 2023

web get the free pearson education science answers 145 pearson education science answers 145 cachri *pearson science 7 10 2nd edition secondary school science* - Oct 10 2022

web overview pearson science 7 10 2nd edition aligns with the national and victorian science curriculum this latest edition has had a thorough literacy review focusing on accessibility for learners and has been designed to encourage students to see a relationship between science and their everyday lives year levels 7 10

free revision material p5 science the science academy - Feb 14 2023

web toa payoh address blk 192 lorong 4 toa payoh 01 674 s310192 tampines address opening in nov 2023 our tampines hub 1 tampines walk b1 19 s528523

**pearson education science answers 145** - May 05 2022

web and evaluation in school and nonschool based physical activity programs written by two academics with backgrounds in physical education teacher education pete the book emphasizes the link between theory and practice and reflects the most recent changes in national physical education programs it covers a full range of

**p5 science test papers free download the learning space** - Mar 15 2023

web free p5 science test papers for download for students preparing for primary 5 exams latest p5 science test papers from top schools menu menu blog posts moe updates 2021 p5 science ba3 anglo chinese school 2021 acs ba1 2 2021 p5 science ba1 and 2 anglo chinese school 2020 ai tong sa2 2020 p5 science sa2 ai tong 2020

**pearson education science answers 145 pivotid uvu** - Mar 03 2022

web nov 7 2023 pearson education science answers 145 2 downloaded from pivotid uvu edu on 2022 07 13 by guest  
machine learning reveals limited contribution of trans only encoded nature com functional evolutionary convergence of long  
noncoding rnas nature com feasibility and impact of school based nutrition education

*pearson education science answers 145* - Jul 19 2023

web pearson education science answers 145 createdtohis com pearson education science answers 145 ubaleh de pearson  
education science answers 145 37 139 20 80 pearson education science answers 145 sitexpress co uk pearson education  
science answers 145 anjaka de

*pearson education science answers 145 pdf* - Sep 09 2022

web bihar stet paper 2 answer key 2023 released on bsebstet com download here times of india how chatgpt can improve  
education not threaten it scientific american jun 08 2017 how chatgpt can improve education not threaten it scientific  
american students lost one third of a school year to pandemic study finds the new york times mar

*int esws at y9 ap sb answers ttppearson* - Sep 21 2023

web answers to the behaviour of pets c suitable suggestions as to why learning and innate behaviours are useful for animals  
9ab inherited variation student book 1 9ab inherited variation 1 three of skin colour leaf colour flesh colour size shape 2 a  
her father b hair colour 3 environmental variation is caused by factors in

*grade five science pep exams preparation yesgsat com* - Aug 08 2022

web 3 do not spend too long on any one question if you do not know the answer and think you may have time at the end move  
on to the next item and comeback to it 4 do not leave any questions unanswered at the end it is always better to take a guess  
you have a one in four chance of being right if you do not answer at all you have no chance

**pearson education science answers 145** - Nov 11 2022

web pearson education science answers 145 brench de pearson education science answers 145 gandrama com pearson  
education science answers 145 pearson education science answers 145 pearson education science answers 145 37 139 20 80  
pearson education science answers 145 persianzalloo com pearson education

**science pearson uk** - Jun 06 2022

web we believe that science education should be available and accessible to all students this section includes our diversity in  
science online event information on our accessible exam papers science options for all students

**pearson education science answers ecosystems and biomes** - Apr 04 2022

web science answers may 28 2022 provides an information library on the main aspects of science and life sciences with an  
emphasis on enquiry this series answers the questions that children ask and addresses the topics that they are required to



research at this level science year 6 answers apr 07 2023

**pearson education science answers 145 pdf** - Jul 07 2022

web may 18 2023 science answers 145 pdf and numerous books collections from fictions to scientific research in any way in the course of them is this pearson education science answers 145 pdf that can be your partner

**pearson education science answers 145 download only** - Jan 13 2023

web apr 4 2023 pearson education science answers 145 is available in our digital library an online permission to it is set as public thus you can download it instantly our digital library saves in multiple countries allowing you to get the most less latency times to download any of our books with this one merely said the pearson education

**textbook answers pearson support central** - Aug 20 2023

web oct 30 2023 a level science pearson textbook answers explains where to find the textbook answers for the pearson a level 2015 sciences 133375 views 30 oct 2023 knowledge

**past papers past exam papers pearson qualifications** - Oct 22 2023

web past papers our easy to use past paper search gives you instant access to a large library of past exam papers and mark schemes they re available free to teachers and students although only teachers can access the most recent papers sat within the past 12 months what past papers are available when and to whom

**a level science pearson textbook answers pearson support** - Dec 12 2022

web oct 30 2023 explains where to find the textbook answers for the pearson a level 2015 sciences oct 30 2023 knowledge