



36" and 42" WOOD BURNING FIREPLACES



INSTALLATION AND OPERATING INSTRUCTIONS

Glass Doors, Fan Assembly, and Outside Combustion Air Kit Available

MODELS:

4000WBA 4000WBA 4000WBCA 4000WBDA
5000WBA 5000WBA 5000WBCA 5000WBDA

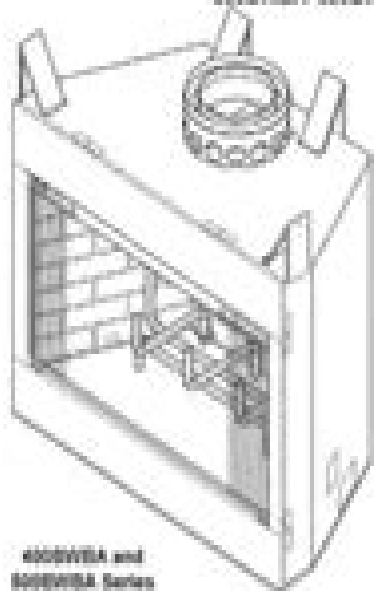

4000WBA and
5000WBA Series
Radiant Type

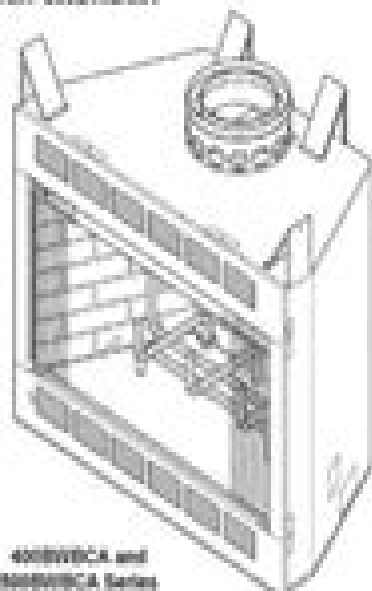

4000WCA and
5000WCA Series
Circulating Type

These fireplaces are U. L.® listed for use with "B" Series chimney system components.

Only Unvented Gas Log Sets which have been found to comply with the Standard For Unvented Room Heaters ANSI Z21.13.2, are to be installed in this fireplace. A hood must be installed when mantle is installed at 12" from fireplace opening.

READ BEFORE INSTALLING. SAVE THESE INSTRUCTIONS



SUPER B-VENT GAS FIREPLACE

INSTALLATION AND OPERATING INSTRUCTIONS

MODEL: BVE436, BVE426, BVE438

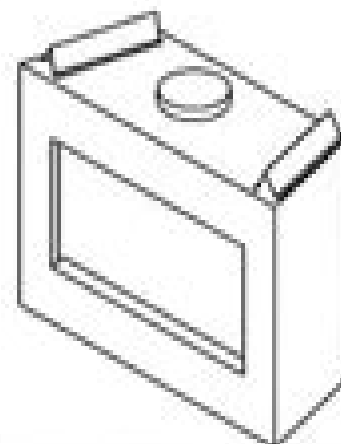

WARNING: If the information in these instructions are not followed exactly, a fire or explosion may result causing property damage, personal injury or death.

- Do not store or use gasoline or other flammable vapors and liquids in the vicinity of this or any other appliance.
- WHAT TO DO IF YOU SMELL GAS**
- Do not try to light any appliance.
- Do not touch any electrical switch, do not use any phone in your building.
- Immediately call your gas supplier from a neighbor's phone. Follow the gas supplier's instructions.
- If you cannot reach your gas supplier, call the fire department.
- Installation and service must be performed by a qualified installer, service agency or the gas supplier.

The appliance may be located in an alternate, previously listed, manufactured home or mobile home, when so prohibited by local codes.

The appliance is only to be used with the type of gas indicated on the rating plate. The appliance is not intended for use with other gases, unless a certificate is used.

For Restricted Use Models (RUE) Requirements For Mechanical Breathing Apparatus

BE TO HIGH TEMPERATURES, THE APPLIANCE SHOULD BE LOCATED OUT OF TRAFFIC AND AWAY FROM FURNITURE AND DRAPES.

CHILDREN AND ANIMALS SHOULD BE ALERTED TO THE HAZARDS OF HIGH SURFACE TEMPERATURE AND SHOULD BE KEPT AWAY TO AVOID BURNS OR EXHAUSTION HAZARD.

YOUTH CHILDREN SHOULD BE SUPERVISED WHEN THEY ARE IN THE SAME ROOM AS THE APPLIANCE.

CLOTHING OR OTHER FLAMMABLE MATERIAL SHOULD NOT BE PLACED ON OR NEAR THE APPLIANCE.

KEEP THE ROOM AREA CLEAR AND FREE FROM COMBUSTIBLE MATERIALS, GASOLINE, AND OTHER FLAMMABLE VAPORS AND LIQUIDS.

• READ BEFORE INSTALLING OR OPERATING AND SAVE THESE INSTRUCTIONS •

Martin Dv3a Manual

F Rizvi



Martin Dv3a Manual:

Reviewing **Martin Dv3a Manual**: Unlocking the Spellbinding Force of Linguistics

In a fast-paced world fueled by information and interconnectivity, the spellbinding force of linguistics has acquired newfound prominence. Its capacity to evoke emotions, stimulate contemplation, and stimulate metamorphosis is really astonishing. Within the pages of "**Martin Dv3a Manual**," an enthralling opus penned by a very acclaimed wordsmith, readers embark on an immersive expedition to unravel the intricate significance of language and its indelible imprint on our lives. Throughout this assessment, we shall delve to the book is central motifs, appraise its distinctive narrative style, and gauge its overarching influence on the minds of its readers.

https://staging.conocer.cide.edu/public/browse/HomePages/Jazz_Blues_Jazz_Piano_Solos_Series.pdf

Table of Contents Martin Dv3a Manual

1. Understanding the eBook Martin Dv3a Manual
 - The Rise of Digital Reading Martin Dv3a Manual
 - Advantages of eBooks Over Traditional Books
2. Identifying Martin Dv3a Manual
 - Exploring Different Genres
 - Considering Fiction vs. Non-Fiction
 - Determining Your Reading Goals
3. Choosing the Right eBook Platform
 - Popular eBook Platforms
 - Features to Look for in an Martin Dv3a Manual
 - User-Friendly Interface
4. Exploring eBook Recommendations from Martin Dv3a Manual
 - Personalized Recommendations
 - Martin Dv3a Manual User Reviews and Ratings
 - Martin Dv3a Manual and Bestseller Lists

5. Accessing Martin Dv3a Manual Free and Paid eBooks
 - Martin Dv3a Manual Public Domain eBooks
 - Martin Dv3a Manual eBook Subscription Services
 - Martin Dv3a Manual Budget-Friendly Options
6. Navigating Martin Dv3a Manual eBook Formats
 - ePub, PDF, MOBI, and More
 - Martin Dv3a Manual Compatibility with Devices
 - Martin Dv3a Manual Enhanced eBook Features
7. Enhancing Your Reading Experience
 - Adjustable Fonts and Text Sizes of Martin Dv3a Manual
 - Highlighting and Note-Taking Martin Dv3a Manual
 - Interactive Elements Martin Dv3a Manual
8. Staying Engaged with Martin Dv3a Manual
 - Joining Online Reading Communities
 - Participating in Virtual Book Clubs
 - Following Authors and Publishers Martin Dv3a Manual
9. Balancing eBooks and Physical Books Martin Dv3a Manual
 - Benefits of a Digital Library
 - Creating a Diverse Reading Collection Martin Dv3a Manual
10. Overcoming Reading Challenges
 - Dealing with Digital Eye Strain
 - Minimizing Distractions
 - Managing Screen Time
11. Cultivating a Reading Routine Martin Dv3a Manual
 - Setting Reading Goals Martin Dv3a Manual
 - Carving Out Dedicated Reading Time
12. Sourcing Reliable Information of Martin Dv3a Manual
 - Fact-Checking eBook Content of Martin Dv3a Manual
 - Distinguishing Credible Sources
13. Promoting Lifelong Learning

- Utilizing eBooks for Skill Development
 - Exploring Educational eBooks
14. Embracing eBook Trends
- Integration of Multimedia Elements
 - Interactive and Gamified eBooks

Martin Dv3a Manual Introduction

In today's digital age, the availability of Martin Dv3a Manual books and manuals for download has revolutionized the way we access information. Gone are the days of physically flipping through pages and carrying heavy textbooks or manuals. With just a few clicks, we can now access a wealth of knowledge from the comfort of our own homes or on the go. This article will explore the advantages of Martin Dv3a Manual books and manuals for download, along with some popular platforms that offer these resources. One of the significant advantages of Martin Dv3a Manual books and manuals for download is the cost-saving aspect. Traditional books and manuals can be costly, especially if you need to purchase several of them for educational or professional purposes. By accessing Martin Dv3a Manual versions, you eliminate the need to spend money on physical copies. This not only saves you money but also reduces the environmental impact associated with book production and transportation. Furthermore, Martin Dv3a Manual books and manuals for download are incredibly convenient. With just a computer or smartphone and an internet connection, you can access a vast library of resources on any subject imaginable. Whether you're a student looking for textbooks, a professional seeking industry-specific manuals, or someone interested in self-improvement, these digital resources provide an efficient and accessible means of acquiring knowledge. Moreover, PDF books and manuals offer a range of benefits compared to other digital formats. PDF files are designed to retain their formatting regardless of the device used to open them. This ensures that the content appears exactly as intended by the author, with no loss of formatting or missing graphics. Additionally, PDF files can be easily annotated, bookmarked, and searched for specific terms, making them highly practical for studying or referencing. When it comes to accessing Martin Dv3a Manual books and manuals, several platforms offer an extensive collection of resources. One such platform is Project Gutenberg, a nonprofit organization that provides over 60,000 free eBooks. These books are primarily in the public domain, meaning they can be freely distributed and downloaded. Project Gutenberg offers a wide range of classic literature, making it an excellent resource for literature enthusiasts. Another popular platform for Martin Dv3a Manual books and manuals is Open Library. Open Library is an initiative of the Internet Archive, a non-profit organization dedicated to digitizing cultural artifacts and making them accessible to the public. Open Library hosts millions of books, including both public domain works and contemporary titles. It also allows users to borrow digital copies of certain books for a limited period, similar to a library.

lending system. Additionally, many universities and educational institutions have their own digital libraries that provide free access to PDF books and manuals. These libraries often offer academic texts, research papers, and technical manuals, making them invaluable resources for students and researchers. Some notable examples include MIT OpenCourseWare, which offers free access to course materials from the Massachusetts Institute of Technology, and the Digital Public Library of America, which provides a vast collection of digitized books and historical documents. In conclusion, Martin Dv3a Manual books and manuals for download have transformed the way we access information. They provide a cost-effective and convenient means of acquiring knowledge, offering the ability to access a vast library of resources at our fingertips. With platforms like Project Gutenberg, Open Library, and various digital libraries offered by educational institutions, we have access to an ever-expanding collection of books and manuals. Whether for educational, professional, or personal purposes, these digital resources serve as valuable tools for continuous learning and self-improvement. So why not take advantage of the vast world of Martin Dv3a Manual books and manuals for download and embark on your journey of knowledge?

FAQs About Martin Dv3a Manual Books

How do I know which eBook platform is the best for me? Finding the best eBook platform depends on your reading preferences and device compatibility. Research different platforms, read user reviews, and explore their features before making a choice. Are free eBooks of good quality? Yes, many reputable platforms offer high-quality free eBooks, including classics and public domain works. However, make sure to verify the source to ensure the eBook credibility. Can I read eBooks without an eReader? Absolutely! Most eBook platforms offer web-based readers or mobile apps that allow you to read eBooks on your computer, tablet, or smartphone. How do I avoid digital eye strain while reading eBooks? To prevent digital eye strain, take regular breaks, adjust the font size and background color, and ensure proper lighting while reading eBooks. What the advantage of interactive eBooks? Interactive eBooks incorporate multimedia elements, quizzes, and activities, enhancing the reader engagement and providing a more immersive learning experience. Martin Dv3a Manual is one of the best book in our library for free trial. We provide copy of Martin Dv3a Manual in digital format, so the resources that you find are reliable. There are also many Ebooks of related with Martin Dv3a Manual. Where to download Martin Dv3a Manual online for free? Are you looking for Martin Dv3a Manual PDF? This is definitely going to save you time and cash in something you should think about.

Find Martin Dv3a Manual :**jazz blues jazz piano solos series**

jazz baby childhood

jena romanticism and its appropriation of jakob bhohme theosophy hagiography literature

jerry mcauleyan apostle to the lost

jessie kesson writing her life

jennys war

jen plays

jefferson vs. hamilton**jazz masters vintage getz vols 12**

jellys blues the life music and redemption of jelly roll morton

jenny lind and the clipper nightingale figurehead publication portsmouth marine society 27

jennifer kries pilates plus method**jean-paul sartre modern masters**

jean cocteau the illustrated ltd

jean royere

Martin Dv3a Manual :

the murder bag parsons tony 9781780892337 amazon com - Aug 27 2022

web aug 7 2014 the murder bag aka the murder man max wolfe 1 is the first novel in a new crime series by tony parsons bestselling british author of man and boy this is the author s first outing into the crime genre and it is definitely a winner

the murder bag parsons tony 9781780892344 amazon com - Mar 22 2022

web aug 5 2014 paperback 24 40 12 used from 6 55 1 new from 24 40 the gripping first novel in an explosive new crime series by tony parsons bestselling author of man and boy if you like crime novels by ian rankin and peter james you will love this there s a serial killer on the loose

murder bag tony parsons mystery crime kitapları - Dec 31 2022

web murder bag kargo bedava gümrük vergisi yok murder bag yazar tony parsons yayınevleri cornerstone kitap formatı

ciltsiz İnce kapak adet yurtdışı fiyatı 8 99 gbp 218 9 tl sepete ekle bu Üründe kargo

the murder bag google books - Jun 24 2022

web detective max wolfe has recently arrived in the homicide division of london s west end central 27 savile row soon he is following the bloody trail from the backstreets and bright lights of the city to the darkest corners of the internet and all

the murder bag the thrilling richard and judy book club pick - Mar 02 2023

web may 8 2014 the murder bag itself is a forensic bag used at murder scenes this is a solid crime novel but overall lacks the light and elegant touch of some of wolfe s european counterparts such as andrea camilleri s detective inspector montalbano camilleri incidentally wrote a book called potter s field featuring montalbano but the murder

the murder bag tony parsons official trailer youtube - Jul 06 2023

web bitly com qoqdsp facebook com tonyparsonsbooks dcmawolfe com the gripping first novel in an explosive new crime series by tony parso

emekli ve memura ek ödeme müjdesi ssk bağ kur kök ücret - Sep 27 2022

web 1 day ago haberler emekli haberleri emekli ve memura ek ödeme müjdesi ssk bağ kur kök ücret ve refah payı ile ilgili düzenleme

the murder bag parsons tony amazon ca books - Feb 18 2022

web the murder bag aka the murder man max wolfe 1 is the first novel in a new crime series by tony parsons bestselling british author of man and boy this is the author s first outing into the crime genre and it is definitely a winner for clarification there are two names for this book murder bag and murder man

the murder bag penguin books uk - May 04 2023

web if the murder bag marks the launch of a new crime series count me in the times a tense debut crime novel with a dose of dry wit the daily express impressive page turning told with conviction and at an ever increasing pace daily mail truly emotive crime writing is a rarity and the murder bag looks set to win tony parsons many new

the murder bag by tony parsons overdrive - Oct 29 2022

web may 8 2014 truly emotive crime writing is a rarity and the murder bag looks set to win tony parsons many new fans in the genre gq read more available to buy format ebook isbn 9780099591054 series max wolfe author tony parsons publisher random house release 08 may 2014 share

review of the murder bag by tony parsons the dreamy - Apr 22 2022

web oct 1 2023 book the murder bag author tony parsons genre crime thriller it s not about how hard you can hit it s about how hard you can get hit and then keep going crime fiction has always been one of my favourite genres it holds the power to ignite a spark of interest and curiosity inside you that ll keep you reading until the end

editions of the murder bag by tony parsons goodreads - Feb 01 2023

web dec 18 2014 editions for the murder bag 1780892330 hardcover published in 2014 kindle edition published in 2014

0099591057 paperback published in 2015 3785

the murder bag by tony parsons waterstones - Apr 03 2023

web jan 1 2015 the murder bag the thrilling richard and judy book club pick dc max wolfe dc max wolfe paperback tony parsons author 12 reviews sign in to write a review 8 99 paperback 464 pages published 01 01 2015 in stock usually dispatched within 2 3 working days

the murder bag tony parsons kitabı ve fiyatı hepsiburada - Aug 07 2023

web the murder bag tony parsons kitabı en iyi fiyatla burada tıkla the murder bag tony parsons eserini hızlı ve kolay bir şekilde satın al

the murder bag tony parsons fiyat satın al d r - Sep 08 2023

web the murder bag kitap açıklaması the gripping first novel in an explosive new crime series by tony parsons bestselling author of man and boy if you like crime novels by ian rankin and peter james you will love this twenty years ago seven rich privileged students became friends at their exclusive private school potter s field

the murder bag parsons tony 1953 free download borrow - Jun 05 2023

web defender of the weak and every murderer s worst nightmare newly arrived in the homicide division of london s west end central 27 savile row max follows the bloody trail from the backstreets and bright lights of the city to the darkest corners of the internet and all the way to the corridors of power

the murder bag the thrilling richard and judy book club pick - Nov 29 2022

web the murder bag the thrilling richard and judy book club pick dc max wolfe parsons tony amazon com tr kitap

the murder bag tony parsons amazon com tr kitap - Jul 26 2022

web the murder bag tony parsons amazon com tr kitap Çerez tercihlerinizi seçin Çerez bildirimimizde ayrıntılı şekilde açıklandığı üzere alışveriş yapmanızı sağlamak alışveriş deneyiminizi iyileştirmek ve hizmetlerimizi sunmak için gerekli olan çerezleri ve benzer araçları kullanırız

the murder bag the thrilling richard and judy book club pick - May 24 2022

web the murder bag the first in the series of books from tony parson featuring dc max wolfe in addition to his police role wolfe is a lone parent with a five year old daughter constantly seeking new ways to manage both his professional and domestic roles

the murder bag max wolfe 1 by tony parsons goodreads - Oct 09 2023

web dec 18 2014 the murder bag aka the murder man max wolfe 1 is the first novel in a new crime series by tony parsons bestselling british author of man and boy this is the author s first outing into the crime genre and it is definitely a winner

ecografia abdominal aprendizaje paso a paso tapa - Sep 04 2022

web siguiendo el método del dr berthold block usted aprenderá a realizar e interpretar la ecografía abdominal vasos hígado hilio hepático vesícula páncreas estómago duodeno diafragma bazo riñones glándulas suprarrenales vejiga próstata y útero
ecografía abdominal aprendizaje paso a paso axon - Feb 09 2023

web descripcion siguiendo el método del dr berthold block usted aprenderá a realizar e interpretar la ecografía abdominal vasos hígado hilio hepático vesícula páncreas estómago duodeno diafragma bazo riñones glándulas suprarrenales vejiga próstata y útero el libro contiene unidades didácticas claras

ecografía abdominal aprendizaje paso a paso pasta blanda - Oct 05 2022

web toda la ecografía normal y toda la patología y la interpretación adecuada en un solo libro desde la sonda a la postura del paciente paso a paso miles de imágenes ecográficas de calidad analizadas con dibujos que representan capas una forma 3 d de aprender lo que vemos en 2 d en la pantalla del ecógrafo leer más isbn 10 8498352819 isbn 13

ecografía abdominal aprendizaje paso a paso block berthold - Nov 06 2022

web block berthold ecografía abdominal aprendizaje paso a paso 5a ed buenos aires ar journal 2016 351 p fot ejemplar de la biblioteca devoto n de patrimonio 29370 entregado en cumplimiento de la ley 934 de depósito legal isbn 978 987 3954 13 9

ecografía abdominal aprendizaje paso a paso semantic scholar - Dec 07 2022

web ecografía abdominal aprendizaje paso a paso semantic scholar corpus id 172411163 ecografía abdominal aprendizaje paso a paso b block published 2011 ecografía abdominal aprendizaje paso a paso libros de medicina diagnostico por la imagen 34 71

curso de ecografía abdominal introducción a la técnica - Apr 30 2022

web el sonido se refracta cuando pasa en dirección oblicua a través de la interfase entre 2 estructuras que transmiten el sonido a diferentes velocidades por ejemplo se puede producir duplicidad de estructuras abdominales profundas aorta por la refracción producida en la unión del músculo recto abdominal y la grasa de la pared abdominal

ecografía abdominal aprendizaje paso a paso 4 ed pdf - Aug 15 2023

web ecografía abdominal libro básico para el estudio en ultrasonido

ecografía abdominal aprendizaje paso a paso tapa blanda - Jun 13 2023

web ecografía abdominal aprendizaje paso a paso tapa blanda 10 febrero 2011 esta cuarta edición de ecografía abdominal completamente revisada y actualizada brinda al lector el conocimiento paso a paso de los fundamentos del estudio ecográfico del

ecografía abdominal aprendizaje paso a paso 36 cuadros - Jul 14 2023

web ecografía abdominal aprendizaje paso a paso 36 cuadros berthold block editorial médica panamericana s a 2011 abdomen 291 pages 0 reviews reviews aren t verified but google

ecografía abdominal aprendizaje paso a paso tirant lo blanch - May 12 2023

web presenta paso a paso los fundamentos de la ecografía del abdomen superior con más de 900 figuras 36 cuadros más de 240 dibujos aclaratorios y tridimensionales para las localizaciones espaciales difíciles un novedoso cu tirant brasil libreria tirant tirant méxico tirant chile tirant colombia tirant online tirant online mex tirant formación

ecografía abdominal aprendizaje paso a paso by block berthold - Jun 01 2022

web jun 20 2023 ecografía abdominal aprendizaje paso a paso ed 5 block utilidad y fiabilidad de la ecografía clínica abdominal en ecografía abdominal aprendizaje pasó a paso laleo ecografía de hombro ecografía fácil libro ecografía abdominal aprendizaje paso a paso lee un libro ecografía abdominal aprendizaje paso a paso axon es

ecografía abdominal medlineplus enciclopedia médica - Jan 28 2022

web una ecografía abdominal es un examen imagenológico se utiliza para ver los órganos internos en el abdomen como el hígado la vesícula biliar el bazo el páncreas y los riñones los vasos sanguíneos que van a algunos de estos órganos como la vena cava inferior y la aorta también se pueden examinar con ultrasonido

ecografía del abdomen tuotromedico - Dec 27 2021

web el ecógrafo es una máquina que emite ultrasonidos de alta frecuencia que aplicados sobre el abdomen llegan a los órganos internos y allí se reflejan hacia fuera esta reflexión se recoge en una imagen tipo televisión en un monitor no se utilizan radiaciones ionizantes en esta prueba con este procedimiento se representan en el monitor las imágenes

ecografía abdominal aprendizaje paso a paso - Apr 11 2023

web siguiendo el método del dr berthold block usted aprenderá a realizar e interpretar la ecografía abdominal vasos hígado hilio hepático vesícula páncreas estómago duodeno diafragma bazo riñones glándulas suprarrenales vejiga próstata y útero

ecografía abdominal aprendizaje paso a paso block youtube - Aug 03 2022

web ecografía abdominal aprendizaje paso a paso 5 ed block block berthold isbn 9789873954139 editorial ediciones journal año 2016 número de edición 5 352 páginas idioma español

ecografía abdominal aprendizaje paso a paso spanish edition - Jul 02 2022

web feb 10 2011 ecografía abdominal aprendizaje paso a paso spanish edition 9788498352818 medicine health science books amazon com

ecografía abdominal aprendizaje paso a paso 5ed medilibro - Jan 08 2023

web siguiendo el método del dr berthold block usted aprenderá a realizar e interpretar la ecografía abdominal vasos hígado hilio hepático vesícula páncreas estómago duodeno diafragma bazo riñones glándulas suprarrenales vejiga próstata y útero el libro contiene unidades didácticas claras

ecografía abdominal aprendizaje paso a paso 4ed medilibro - Mar 10 2023

web esta cuarta edición de ecografía abdominal completamente revisada y actualizada brinda al lector el conocimiento paso a paso de los fundamentos del estudio ecográfico del abdomen se mantiene así válida la premisa con la que se concibió la primera edición un libro para tener junto a la camilla del paciente durante la exploración

[ecografia abdominal aprendizaje paso a paso old vulkk com](#) - Mar 30 2022

web ecografia abdominal aprendizaje paso a paso 1 ecografia abdominal aprendizaje paso a paso vessel health and preservation the right approach for vascular access

[loading interface goodreads](#) - Feb 26 2022

web jan 1 2015 siguiendo el método del dr berthold block usted aprenderá a realizar e interpretar la ecografía abdominal vasos hígado hilio hepático vesícula páncreas

question chain per la scuola media libreria universitaria - Jan 09 2023

web acquista question chain per la scuola media 9788853604682 con il 5 di sconto su libreria universitaria acquista tutti i libri per la tua scuola e ricevili direttamente a casa tua

question chain per la scuola media amazon it - Dec 08 2022

web question chain per la scuola media guillemant dominique amazon it libri passa al contenuto principale it in consegna a roma 00185 accedi per aggiornare la tua posizione libri seleziona la categoria in cui desideri effettuare la ricerca ricerca amazon it

questions à la chaine per la scuola media by dominique - Oct 06 2022

web questions à la chaine per la scuola media by dominique guillemant l europa una questione di valori coe april 10th 2020 sebbene il gioco sia adatto anche a piccoli gruppi con un minimo di due persone è stato concepito principalmente per le classi con la guida di un insegnante la brochure cartacea contiene 1 tabellone formato a1 48 carte

questions à la chaine per la scuola media a2 b2 amazon it - Jul 15 2023

web questions à la chaine per la scuola media a2 b2 guillemant dominique amazon it libri libri libri universitari umanistica scegli il tuo indirizzo ne hai uno da vendere visualizza tutte le 2 immagini questions à la chaine per la scuola media a2 b2 copertina flessibile 1 gennaio 2010 edizione francese di dominique guillemant autore

questions a la chaine per la scuola media pdf wrbb neu - Nov 07 2022

web it will categorically ease you to see guide questions a la chaine per la scuola media as you such as by searching the title publisher or authors of guide you truly want you can discover them rapidly

[questions à la chaine per la scuola media 9788853604699](#) - Feb 10 2023

web questions à la chaine per la scuola media è un libro di guillemant dominique pubblicato da eli nella collana giochi didattici isbn 9788853604699

25 questions sur l'école podcastfrancaisfacile com - Jan 29 2022

web voici une série de 25 questions répondez en utilisant autant que possible des adjectifs et des pronoms indéfinis développez et variez les réponses pour vous aider à répondre un exemple de réponse est proposé pour chaque question essayez de donner votre propre avis les réponses sont libres activités en relation dialogue

questions a la chaine per la scuola media 2015eeglobalsip - May 01 2022

web apr 7 2023 we present you this proper as capably as easy way to get those all we provide questions a la chaine per la scuola media and numerous book collections from fictions to scientific research in any way in the course of them is this questions a la chaine per la scuola media that can be your partner

questions à la chaine per la scuola media by dominique - Aug 04 2022

web questions à la chaine per la scuola media by dominique guillemant questions à la chaine per la scuola media by dominique guillemant jean bodin stanford encyclopedia of philosophy libri guillemant dominique catalogo libri di dominique lyricstraining fr über 80 neue produkte zum festpreis eutelsat 5 west a eutelsat 5 west b 5 w tutte le

questions a la chaine per la scuola media michel foucault - Mar 11 2023

web merely said the questions a la chaine per la scuola media is universally compatible with any 2 devices to read mathematical reviews 1991 question chain dominique guillemant 2010 middeleeuws gebruiksaardewerk in nederland a a a verhoeven 1998 01 01 kugeltopf

questions a la chaine per la scuola media download only - Sep 05 2022

web questions a la chaine per la scuola media 1 questions a la chaine per la scuola media revue des questions scientifiques l organisation scientifique du travail des lettres et des arts chez les peuples de la belgique avant le septième siècle cup archive 81 reports presented by experts from 18 countries give an overall perspective of

questions à la chaine per la scuola media 9788853604699 di - May 13 2023

web acquista online questions à la chaine per la scuola media 9788853604699 di dominique guillemant approfitta subito di sconti fino al 50 sui su libri e testi scolastici nuovi e usati

domande e risposte unascuola it - Feb 27 2022

web jul 19 2013 so tutto domande quiz di italiano inglese storia geografia scienze arte e musica sport corredate di risposte utilizzabili per giochi individuali o a squadre o per semplice curiosità conoscitiva da parte dei bambini della scuola primaria la parola quiz ha il significato di quesito indovinello

questions à la chaine per la scuola media questions a la chaine - Jun 14 2023

web questions à la chaine per la scuola media questions a la chaine guillemant dominique amazon com au books

questions a la chaine per la scuola media copy old talentsprint - Jul 03 2022

web questions a la chaine per la scuola media mémoire sur la question quel étoit l habillement le langage l état de l agriculture du commerce des lettres des arts chez les peuples de la belgique avant le septième siècle

questions à la chaine per la scuola media mondadori store - Aug 16 2023

web acquista online il libro questions à la chaine per la scuola media di dominique guillemant in offerta a prezzi imbattibili su mondadori store

questions à la chaine per la scuola media by dominique - Dec 28 2021

web dominique catalogo libri di dominique ca movies amp tv l europa una questione di valori coe glass bangles wedding indian ethnic classic questions à la chaine per la scuola media by dominique guillemant may 26th 2020 12manage has helped me to do better in my mba program because i get all i want from 12manage thanks so much great

questions à la chaine per la scuola media by dominique - Mar 31 2022

web questions à la chaine per la scuola media by dominique guillemant may 26th 2020 amazing videos and presentations created with powtoon when you can t afford to be ignored use a powtoon to grab the attention of your bosses and colleagues in any business situation fight distractions in class and grab your students attention by making

questions à la chaine per la scuola media libreria universitaria - Apr 12 2023

web questions à la chaine per la scuola media libro di dominique guillemant pubblicato da eli collana giochi didattici 2010 9788853604699

questions à la chaine per la scuola media by dominique - Jun 02 2022

web may 8th 2020 questions à la chaine per la scuola media libro guillemant dominique edizioni eli collana giochi didattici 2010 14 50 roundtrip of britain and ireland per la scuola media libro guillemant dominique