

Bookmarks

- Accessories
- Index
- EXPLORER 80
  - ACCESSORIES
  - GENERAL
    - AUXILIARY HYDRAULIC DISTRIBUTOR
    - AUXILIARY HYDRAULIC DISTRIBUTOR
    - AUXILIARY HYDRAULIC DISTRIBUTOR

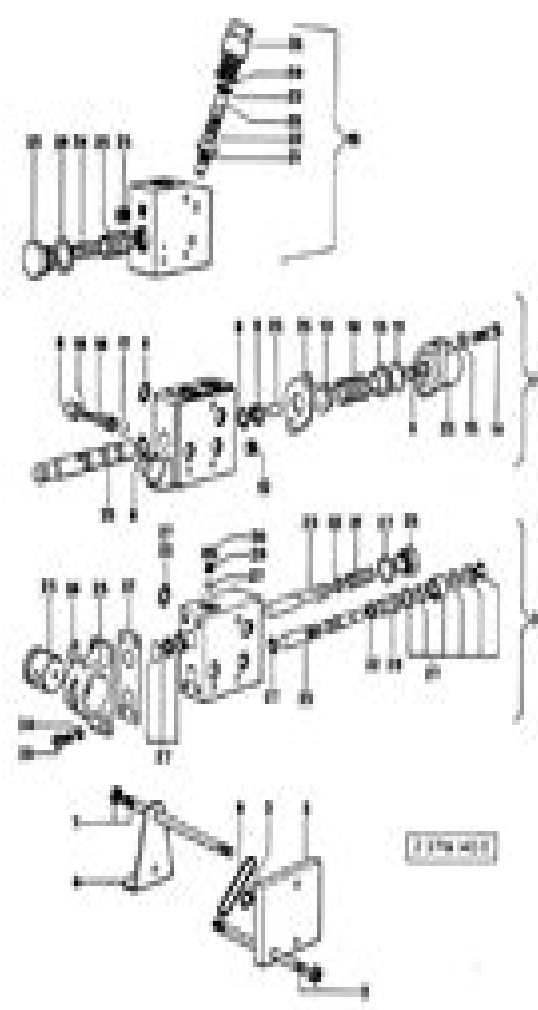

EXPLORER 80			
Revision: ACCESSORIES			
HYDRAULIC DISTRIBUTOR PARTS			
Fig	Code	QTY	Name
1	2 0716 140 0	1	distributor
2	2 0716 140 0	1	gasket set
3	2 0402 226 1	2	stud bolt
4	0 07920 77 4	1	nut lock
5	2 1500 001 0	1	1" ring 15 15x2 02
6	0 07920 76 0	2	square
7	0 07920 86 0	1	plate
8	2 1402 116 0	1	1" ring 45 45x2 02
9	0 07920 86 4	1	distributor
10	0 07920 86 4	1	stud ring set
11	2 0716 110 4	1	cover
12	0 07920 81 0	1	spring
13	0 0617 00 0	1	stud mm 0 20
14	2 0716 040 1	1	plug m 10 g 1 0
15	0 07920 71 0	1	small cover
16	2 0020 411 1	1	oil pan
17	2 1470 001 2	1	washer 1, v128
18	2 0716 040 2	1	spring
19	2 0716 040 3	1	nut
20	2 0716 040 4	1	nut
21	2 0716 140 1	1	plate
22	2 1500 010 0	1	gasket 10.2 x 22 x 1.0
23	2 1500 017 0	1	gasket 22.0 x 27
24	0 07920 71 4	1	valve
25	2 0716 140 2	1	spring
26	0 07920 74 0	1	stud mm 0 20
27	0 07920 75 0	1	stud mm 0 10
28	0 07920 76 0	1	spring
29	0 000 2000 1	1	nut self-locking
30	2 0716 141 0	1	distributor
31	2 0716 140 0	1	gasket set
32	2 0716 140 4	1	spring
33	2 0716 140 5	1	spring
34	2 0716 141 2	1	tap-washer
35	2 0716 141 1	1	spring
36	2 0716 140 3	1	cover
37	2 1500 001 0	1	1" ring 15 15x2 02
38	2 1470 001 2	1	washer 1, v128
39	2 0000 404 1	2	cover m 8 g 1 x 14
40	2 1720 004 0	1	key 2x4 0
41	2 0716 140 7	1	plate mm 0 20
42	2 0716 140 8	1	plate mm 0 20

# Manual Del Same

**David Kirk**



## Manual Del Same:

*Index-catalogue of the Library of the Surgeon-General's Office, United States Army* Library of the Surgeon-General's Office (U.S.),1889     *Index-catalogue of the Library of the Surgeon-General's Office, United States Army National Library of Medicine (U.S.),1914*     **Catalogue of the Library of the Arnold Arboretum of Harvard University** Arnold Arboretum. Library,1917     *Index-catalogue of the Library of the Surgeon General's Office, United States ,1889*     **Catalogue of the Library of the Arnold Arboretum of Harvard University: Subject catalogue with supplement to volume I.** Arnold Arboretum. Library,1917     **United States Government Publications, a Monthly Catalog** United States. Superintendent of Documents,1949 February issue includes Appendix entitled Directory of United States Government periodicals and subscription publications September issue includes List of depository libraries June and December issues include semiannual index     **Index-catalogue of the Library of the Surgeon General's Office, United States Army** Army Medical Library (U.S.),Library of the Surgeon-General's Office (U.S.),1918     **Publication ,1898**     **Sources of Information on Military Professional Subjects** United States. Adjutant-General's Office. Military Information Division,1896     *Culinary Colonialism, Caribbean Cookbooks, and Recipes for National Independence* Keja L. Valens,2024-02-16 Women across the Caribbean have been writing reading and exchanging cookbooks since at least the turn of the nineteenth century These cookbooks are about much more than cooking Through cookbooks Caribbean women and a few men have shaped embedded and contested colonial and domestic orders delineated the contours of independent national cultures and transformed tastes for independence into flavors of domestic autonomy *Culinary Colonialism Caribbean Cookbooks and Recipes for National Independence* integrates new documents into the Caribbean archive and presents them in a rare pan Caribbean perspective The first book length consideration of Caribbean cookbooks *Culinary Colonialism* joins a growing body of work in Caribbean studies and food studies that considers the intersections of food writing race class gender and nationality A selection of recipes culled from the archive that *Culinary Colonialism* assembles allows readers to savor the confluence of culinary traditions and local specifications that connect and distinguish national cuisines in the Caribbean

## Whispering the Techniques of Language: An Emotional Quest through **Manual Del Same**

In a digitally-driven world wherever displays reign great and instant communication drowns out the subtleties of language, the profound strategies and psychological subtleties concealed within words often move unheard. However, located within the pages of **Manual Del Same** a charming fictional value pulsing with natural feelings, lies an exceptional journey waiting to be undertaken. Written by an experienced wordsmith, this charming opus invites viewers on an introspective trip, lightly unraveling the veiled truths and profound affect resonating within the material of each word. Within the psychological depths of this touching evaluation, we shall embark upon a heartfelt exploration of the book's core themes, dissect their fascinating publishing model, and succumb to the strong resonance it evokes strong within the recesses of readers' hearts.

[https://staging.conocer.cide.edu/files/publication/HomePages/ImS\\_In\\_The\\_Parallel\\_Sysplex.pdf](https://staging.conocer.cide.edu/files/publication/HomePages/ImS_In_The_Parallel_Sysplex.pdf)

### **Table of Contents Manual Del Same**

1. Understanding the eBook Manual Del Same
  - The Rise of Digital Reading Manual Del Same
  - Advantages of eBooks Over Traditional Books
2. Identifying Manual Del Same
  - Exploring Different Genres
  - Considering Fiction vs. Non-Fiction
  - Determining Your Reading Goals
3. Choosing the Right eBook Platform
  - Popular eBook Platforms
  - Features to Look for in an Manual Del Same
  - User-Friendly Interface
4. Exploring eBook Recommendations from Manual Del Same
  - Personalized Recommendations
  - Manual Del Same User Reviews and Ratings

- Manual Del Same and Bestseller Lists
- 5. Accessing Manual Del Same Free and Paid eBooks
  - Manual Del Same Public Domain eBooks
  - Manual Del Same eBook Subscription Services
  - Manual Del Same Budget-Friendly Options
- 6. Navigating Manual Del Same eBook Formats
  - ePub, PDF, MOBI, and More
  - Manual Del Same Compatibility with Devices
  - Manual Del Same Enhanced eBook Features
- 7. Enhancing Your Reading Experience
  - Adjustable Fonts and Text Sizes of Manual Del Same
  - Highlighting and Note-Taking Manual Del Same
  - Interactive Elements Manual Del Same
- 8. Staying Engaged with Manual Del Same
  - Joining Online Reading Communities
  - Participating in Virtual Book Clubs
  - Following Authors and Publishers Manual Del Same
- 9. Balancing eBooks and Physical Books Manual Del Same
  - Benefits of a Digital Library
  - Creating a Diverse Reading Collection Manual Del Same
- 10. Overcoming Reading Challenges
  - Dealing with Digital Eye Strain
  - Minimizing Distractions
  - Managing Screen Time
- 11. Cultivating a Reading Routine Manual Del Same
  - Setting Reading Goals Manual Del Same
  - Carving Out Dedicated Reading Time
- 12. Sourcing Reliable Information of Manual Del Same
  - Fact-Checking eBook Content of Manual Del Same
  - Distinguishing Credible Sources

13. Promoting Lifelong Learning
  - Utilizing eBooks for Skill Development
  - Exploring Educational eBooks
14. Embracing eBook Trends
  - Integration of Multimedia Elements
  - Interactive and Gamified eBooks

### **Manual Del Same Introduction**

Manual Del Same Offers over 60,000 free eBooks, including many classics that are in the public domain. Open Library: Provides access to over 1 million free eBooks, including classic literature and contemporary works. Manual Del Same Offers a vast collection of books, some of which are available for free as PDF downloads, particularly older books in the public domain. Manual Del Same : This website hosts a vast collection of scientific articles, books, and textbooks. While it operates in a legal gray area due to copyright issues, its a popular resource for finding various publications. Internet Archive for Manual Del Same : Has an extensive collection of digital content, including books, articles, videos, and more. It has a massive library of free downloadable books. Free-eBooks Manual Del Same Offers a diverse range of free eBooks across various genres. Manual Del Same Focuses mainly on educational books, textbooks, and business books. It offers free PDF downloads for educational purposes. Manual Del Same Provides a large selection of free eBooks in different genres, which are available for download in various formats, including PDF. Finding specific Manual Del Same, especially related to Manual Del Same, might be challenging as theyre often artistic creations rather than practical blueprints. However, you can explore the following steps to search for or create your own Online Searches: Look for websites, forums, or blogs dedicated to Manual Del Same, Sometimes enthusiasts share their designs or concepts in PDF format. Books and Magazines Some Manual Del Same books or magazines might include. Look for these in online stores or libraries. Remember that while Manual Del Same, sharing copyrighted material without permission is not legal. Always ensure youre either creating your own or obtaining them from legitimate sources that allow sharing and downloading. Library Check if your local library offers eBook lending services. Many libraries have digital catalogs where you can borrow Manual Del Same eBooks for free, including popular titles. Online Retailers: Websites like Amazon, Google Books, or Apple Books often sell eBooks. Sometimes, authors or publishers offer promotions or free periods for certain books. Authors Website Occasionally, authors provide excerpts or short stories for free on their websites. While this might not be the Manual Del Same full book , it can give you a taste of the authors writing style. Subscription Services Platforms like Kindle Unlimited or Scribd offer subscription-based access to a wide range of Manual Del Same eBooks, including some popular titles.

## FAQs About Manual Del Same Books

**What is a Manual Del Same PDF?** A PDF (Portable Document Format) is a file format developed by Adobe that preserves the layout and formatting of a document, regardless of the software, hardware, or operating system used to view or print it.

**How do I create a Manual Del Same PDF?** There are several ways to create a PDF: Use software like Adobe Acrobat, Microsoft Word, or Google Docs, which often have built-in PDF creation tools. Print to PDF: Many applications and operating systems have a "Print to PDF" option that allows you to save a document as a PDF file instead of printing it on paper. Online converters: There are various online tools that can convert different file types to PDF.

**How do I edit a Manual Del Same PDF?** Editing a PDF can be done with software like Adobe Acrobat, which allows direct editing of text, images, and other elements within the PDF. Some free tools, like PDFescape or Smallpdf, also offer basic editing capabilities.

**How do I convert a Manual Del Same PDF to another file format?** There are multiple ways to convert a PDF to another format: Use online converters like Smallpdf, Zamzar, or Adobe Acrobat's export feature to convert PDFs to formats like Word, Excel, JPEG, etc. Software like Adobe Acrobat, Microsoft Word, or other PDF editors may have options to export or save PDFs in different formats.

**How do I password-protect a Manual Del Same PDF?** Most PDF editing software allows you to add password protection. In Adobe Acrobat, for instance, you can go to "File" -> "Properties" -> "Security" to set a password to restrict access or editing capabilities. Are there any free alternatives to Adobe Acrobat for working with PDFs? Yes, there are many free alternatives for working with PDFs, such as: LibreOffice: Offers PDF editing features. PDFsam: Allows splitting, merging, and editing PDFs. Foxit Reader: Provides basic PDF viewing and editing capabilities. How do I compress a PDF file?

You can use online tools like Smallpdf, ILovePDF, or desktop software like Adobe Acrobat to compress PDF files without significant quality loss. Compression reduces the file size, making it easier to share and download. Can I fill out forms in a PDF file? Yes, most PDF viewers/editors like Adobe Acrobat, Preview (on Mac), or various online tools allow you to fill out forms in PDF files by selecting text fields and entering information. Are there any restrictions when working with PDFs?

Some PDFs might have restrictions set by their creator, such as password protection, editing restrictions, or print restrictions. Breaking these restrictions might require specific software or tools, which may or may not be legal depending on the circumstances and local laws.

## Find Manual Del Same :

ims in the parallel sysplex

**in for winter out for spring**

in pleasant places

[in der strafkolonie](#)

[in a larger sense rediscovering lincolns america and restoring american principles](#)

**in a raging inferno combat units of the hitler youth 194445**

**improving your health with niacin vitamin b3**

**in praise of common things lizette woodworth reese revisited**

~~in gods hand meditations for the sick and their families by...~~

[in celebration of small things](#)

**in a lonely place**

[in one era and out the other](#)

[improvising rivers poems](#)

**in his likeness**

[imran learns about quran](#)

**Manual Del Same :**

**mcq on environmental pollution easybiologyclass** - Aug 28 2022

web environmental protection ker hokheng 509 plays 20 questions copy edit live session assign show answers see preview  
multiple choice 30 seconds 1 pt how

**100 mcqs on environmental pollution with answers pdf** - Oct 10 2023

a physical weathering b chemical weathering c erosion d none of the above answer physical weathering see more  
*environmental conservation quizzes study com* - Apr 23 2022

web dear students welcome to mcq on environmental pollution this mcq set consists of ecology and environmental sciences  
multiple choice questions from the topic

**multiple choice questions on pollution environmental chemistry** - Nov 30 2022

web chapter 6 multiple choice questions global environmental politics student resources learning link return to global  
environmental politics student resources chapter 6

**environmental pollution mcq free pdf objective question** - Sep 28 2022

web mar 21 2023 sample question the nfpa standard for competence of responders to hazardous materials weapons of mass  
destruction incidents is nfpa 472 nfpa 1472

[environment management mcq multiple choice questions](#) - Jul 27 2022

web 19 all are primary pollutants except a ammonia b peroxy acyl nitrate pan c sulphur dioxide d hydrogen sulphide 20



pollutants that are introduced into the environment by  
[water pollution mcq quiz pdf questions answers](#) - Nov 18 2021

web in this section you ll find a wide range of environmental pollution mcq questions that explore various aspects of environmental pollution problems each mcq is crafted to

**250 top mcqs on environmental pollution and answers** - May 25 2022

web nov 8 2023 get environmental pollution multiple choice questions mcq quiz with answers and detailed solutions download these free environmental pollution mcq

**mcqs on environmental pollution with answers mcq press** - Jul 07 2023

a phase out the use of cfc s which cause depletion of the ozone layer b reduces the greenhouse effect c protect endangered species d ban nuclear see more

*environment mcq free pdf objective question answer for* - Feb 19 2022

web view answer question which of the following would be natural pollution a forest fires b eutrophication c occurrence of smog d occurrence of no2 in the atmosphere

[environment management multiple choice questions and](#) - Mar 23 2022

web 1 natural resources the section contains multiple choice questions and answers on renewable and non renewable resources mineral resources of india energy production

**environmental pollution and control mcq free pdf objective** - Sep 09 2023

a causing irritation to the eyes and skin b aggravating asthma problem c decreasing blood s ability to transport oxygen d none of the above answer see more

*environmental protection 509 plays quizizz* - Jan 01 2023

web pollutants 2 in many developing countries people use contaminated by hazardous waste and sewage water air facilities 3 regions are often

**mcq on environment protection act with answers mcq press** - Dec 20 2021

web quizzes 119 how pollution contributes to habitat destruction view quiz protecting the environment as an individual view quiz endangered asian animals quiz

**pollution quiz englishclub** - May 05 2023

web oct 25 2023 get environmental pollution and control multiple choice questions mcq quiz with answers and detailed solutions download these free environmental

**multiple choice questions on environmental pollution mcq** - Jan 21 2022

web chemistry multiple choice questions on environmental pollution 1 a substance which causes pollution is known as which

of the following a pollutant b carcinogen

**24 pollution quizzes questions answers trivia proprofs** - Feb 02 2023

web 1 pt what are harmful materials in the environment nonrenewable resources recycle reuses pollution multiple choice 30

seconds 1 pt which word means to use less of

protecting the environment 115 plays quizizz - Jun 06 2023

a cardiac problem b respiratory problems c throat problems d skin infection answer respiratory problems see more

*environmental pollution mcq free pdf objective* - Aug 08 2023

a point source and non point source b primary and secondary pollutants c natural or anthropogenic pollutants d none of the above answer primary and see more

*objective questions on environmental pollution examsegg* - Jun 25 2022

web what are pops view quiz the nitrogen cycle acid rain and fossil fuels view quiz environmental protection for safety

professionals view quiz asbestosis vs

*chapter 6 multiple choice questions global environmental* - Apr 04 2023

web nov 6 2023 get environmental pollution multiple choice questions mcq quiz with answers and detailed solutions

download these free environmental pollution mcq

**multiple choice questions fiveable** - Mar 03 2023

web 20 11 2021 by sunny environmental pollution mcqs if you are looking for environmental science multiple choice

questions then you are at the right place in

**pollution quizzes study com** - Oct 30 2022

web dec 20 2021 image from pixabay plastic pollution presents a huge ecological issue as it floats doesn't decompose and is composed of toxic elements facts about the test the

**study guide with student solutions manual volume 1 for serway jewett** - Jan 31 2023

web feb 16 2022 created by importbot imported from better world books record study guide with student solutions manual

volume 1 for serway jewett's physics for scientists and engineers 9th by raymond a serway john w

**solution manual serway jewett e books for engineers** - Jun 23 2022

web solution manual serway jewett physics for scientists and engineers with modern physics 9th ed drive google com open

drive google com serway jewett

the leading provider of higher education course materials - Jul 25 2022

web achieve success in your physics course by making the most of what physics for scientists and engineers has to offer from

a host of in text features to a range of outstanding tech

**student solutions manual volume 1 for serway jewett s physics** - Nov 28 2022

web oct 21 2009 amazon com student solutions manual volume 1 for serway jewett s physics for scientists and engineers 8th 9781439048542 serway raymond a jewett john w books books

study guide with student solutions manual volume 1 for serway jewett - Aug 26 2022

web jan 1 2013 study guide with student solutions manual volume 1 for serway jewett s physics for scientists and engineers authors raymond a serway john w jewett edition 9 publisher

*solution manual for physics for scientists and engineers 9th edition* - Jun 04 2023

web solution manual for physics for scientists and engineers 9th edition serway jewett 1133947271 9781133947271 free download as pdf file pdf text file txt or read online for free solutions manual

physics for scientists and engineers 9th edition textbook solutions - Jul 05 2023

web what are chegg study step by step physics for scientists and engineers 9th edition solutions manuals chegg solution manuals are written by vetted chegg calculus based physics experts and rated by students so

*free solutions manual for serway 9th edition jewett* - Mar 21 2022

web student solutions manual with study guide volume 2 for serway faughn vuille s college physics 9th jan 22 2023 for chapters 15 30 this manual contains detailed solutions to approximately twelve problems per chapter these problems are indicated in the textbook with boxed problem numbers the manual also features a

**amazon in serway jewett books** - Feb 17 2022

web jul 1 2017 physics for scientists and engineers with modern physics technology update old edition by raymond serway and john jewett 1 january 2015 4 5 out of 5 stars 125 hardcover by jewett serway 1 january 2019 paperback principles of physics by raymond a serway 1 february 1994

*study guide with student solutions manual volume 1 for serway jewett* - Mar 01 2023

web jan 1 2013 study guide with student solutions manual volume 1 for serway jewett s physics for scientists and engineers 9th 9th edition by raymond a serway author john w jewett contributor

**physics for scientists and engineers 9th edition solutions and** - Sep 07 2023

web physics physics for scientists and engineers 9th edition isbn 9781133947271 alternate isbns john w jewett raymond a serway textbook solutions verified chapter 1 mechanics exercise 1a exercise 1b exercise 2 exercise 3 exercise 4 exercise 5 exercise 6 exercise 7 exercise 8 exercise 9a exercise 9b exercise 10a exercise 10b exercise 10c

**physics for scientists and engineers 9th edition serway solutions manual** - Oct 08 2023

web physics for scientists and engineers 9th edition serway solutions manual full clear download no error formatting at testbanklive com download physics for scientists and engineers 9th edition serway solutions manual physics for scientists and

engineers 9th edition serway test bank full clear download no error formatting

**physics 9th ed serway jewett pdf 53 08 mb pdf room** - May 23 2022

web feb 28 2021 physics 9th ed serway jewett free pdf download serway jewett 1 622 pages year 2013 physics read online pdf room

solution manual for physics for scientists and engineers 9th edition - Dec 30 2022

web solution manual for physics for scientists and engineers 9th edition by serway and jewett ch1 ch2 pdf free download as pdf file pdf text file txt or read online for free

physics serway jewett 9th edition solutions - Apr 21 2022

web student solutions manual and study guide for serway and jewett s physics for scientists and engineers with modern physics sixth edition john r gordon 2004 written by john r gordon ralph mcgrew and raymond serway the two volume manual features detailed solutions to 20 percent of the end of chapter problems from the text this

*serway jewett physics for scientists and engineers with* - Aug 06 2023

web dec 9 2018 serway jewett physics for scientists and engineers with modern physics 9ed free download borrow and streaming internet archive

physics for scientists and engineers 9th edition prepscholar - Apr 02 2023

web physics for scientists and engineers 9th edition authors raymond a serway john w jewett isbn 13 978 1133947271 see our solution for question 1 from chapter 1 from physics for scientists and engineers by serway and jewett

*student solutions manual and study guide archive org* - May 03 2023

web feb 15 2022 english volume 9 2 volumes 28 cm access restricted item true addeddate 2022 02 15 11 16 38 associated names gordon john r john robert author serway raymond a author jewett john w author guide to expression serway raymond a physics for scientists and engineers ninth edition bookplateleaf 0002 boxid

**solutions for serway 9th edition jewett 2022 esource svb** - Sep 26 2022

web boxes around their numbers identify problems in the 2 2 solutions for serway 9th edition jewett 2022 10 14 textbook whose complete solutions are found in the manual the manual also features a list of important equations and concepts as well as answers to selected end of chapter questions

student solutions manual with study guide for serway jewett s - Oct 28 2022

web may 18 2012 raymond a serway john w jewett cengage learning may 18 2012 education 656 pages this two volume manual features detailed solutions to 20 percent of the end of chapter problems from the text plus lists of important equations and concepts other study aids and answers to selected end of chapter questions

**indian army gd agniveer previous year paper** - May 11 2023

web 13 hours ago the indian army gd agniveer written exam syllabus includes topics from general knowledge general science numeral ability and mathematics check out the

**indian army agniveer general duty question papers with** - Feb 08 2023

web jan 27 2023 indian army agniveer general duty exam pattern 2022 candidates should have a good idea of the exam pattern for the written exam this will help their

**agniveer indian army clerk sample papers and previous year** - Feb 25 2022

web apr 12 2023 either way you are just on the right path keep going if you are looking for the army clerk sample papers and previous year s papers then the link to download

**indian army gd selection process 2023 prepp** - Jan 27 2022

web may 4 2023 the recruitment exam will be conducted in multiple phases candidates qualifying all the levels of the indian army gd selection process will be called for the

**army gd agniveer sample paper 2022 army gd original** - Dec 06 2022

web sep 8 2022 army gd agniveer sample paper 2022 army gd original paper army agniveer exam tyari army study army exam all trade complete live course ssc gd cour

indian army model test paper and syllabus army rally bharti 2022 - Oct 24 2021

web model test paper cee soldier general duty free english pdf download havaldar education recruitment common model paper havaldar indian army clerk exam

indian army agniveer general duty question papers with - Oct 04 2022

web may 19 2023 if you are looking for indian army agniveer general duty question papers this article is for you we are providing full length as well as chapter wise question

*agniveer army written exam important questions* - Jul 13 2023

though there are tons of reading and practicing material available on the internet but still here are some suggested books for indian army gd written exam see more

indian army soldier previous question papers pdf gd old - Aug 02 2022

web mar 18 2021 so make these indian army soldier gd question papers as essential resources while preparing for the indian army soldier general duty written test at the

**indian army agniveer general duty study material 2023** - May 31 2022

web how are you planning to succeed in the indian army general duty 2023 exam do not worry if you are unsure we are here to assist you in passing the indian army agniveer

**indian army gd practice set pdf sample papers** - Nov 05 2022

web sep 4 2023 get indian army gd mock test series here army gd written exam sample question paper with solution join indian army solved test papers with explanation find

**indian army general duty previous exam paper 9 ufjus com** - Dec 26 2021

web jun 22 2020 army gd exam previous question paper 1 army gd exam previous question paper 2 army gd exam previous question paper 3 army gd exam

*army genral written exam paper secure4 khronos* - Nov 24 2021

web jun 14 2023 this army genral written exam paper as one of the predominant operational sellers here will wholly be paired with by the best alternatives to review so

*indian army gd written exam syllabus topics* - Aug 14 2023

want to fulfill your dream want to be the part of one of the world s biggest army want to get recruited in indian army you can do it with the right track and a good strategy and it will be all done if you want tips on how to prepare for indian armywritten exam then click on the link given first of all let me see more

**check indian army agniveer syllabus exam pattern 2023 pdf** - Sep 22 2021

web indian army agniveer syllabus exam pattern 2023 pdf download check subject wise topics marking scheme agniveer selection process etc as per indian army norms

*armygenralwrittenexampaper pdf dev sfcg* - Jul 01 2022

web examinations so indian army soldiers technical mer examination is one of them this examination held four times a year indian army technical written examination

**army online exam cee syllabus and model paper** - Apr 10 2023

web indian army gd agniveer previous year paper download pdf here indian army gd agniveer previous year papers download the free pdf of the previous year s question

**army genral written exam paper pdf uniport edu** - Sep 03 2022

web apr 12 2023 test consists of four papers revolving around the topics like general mental ability current army genral written exam paper 2 7 downloaded from uniport edu ng

*agniveer army gd 2023 mock test testbook com* - Jun 12 2023

one of the best ways to prepare for any exam is practicing the previous years papers they not only give you the idea about the types of questions that are asked see more

indian army gd 2021 question paper with answer key - Jan 07 2023

web jun 30 2022 in this indian army gd 2021 exam paper the question is of general knowledge 30 questions general science 40 questions and maths 30 questions total of

[agniveer indian army soldier gd sample and previous](#) - Mar 09 2023

web sep 8 2023 agniveer general duty cee syllabus indian army online exam cee for agniveer gd generally comprises of objective type questions on general knowledge

[indian army gd previous question papers pdf army soldier](#) - Mar 29 2022

web indian army soldier gd previous model papers are provided on this page for download the joinindianarmy nic in the indian army soldier gd written exam will be held soon

**indian army syllabus 2023 gd exam pattern download pdf** - Apr 29 2022

web feb 27 2023 indian army gd syllabus 2023 the indian army general duty exam syllabus 2023 is given in the table below after going through the exam pattern aspirants