

### Machine Status Window

X	120.5000
Y	20.0960
Z	-28.0000
A	0.0000
B	0.0000
C	0.0000

-0000.1700  
-0000.1000  
0.0000  
0.0000  
0.0000  
0.0000

S<sub>1</sub> 2002  
S<sub>2</sub> 50  
S<sub>3</sub> 0

F 570

1	4%
2	5%
3	1%
4	0%
5	0%
6	10%

0000	0000	0.0%
0010	0000	0.0%
0020	0000	0.0%
0030	0000	0.0%
0040	0000	0.0%
0050	0000	0.0%
0060	0000	0.0%
0070	0000	0.0%
0080	0000	0.0%
0090	0000	0.0%

### Graphic Window

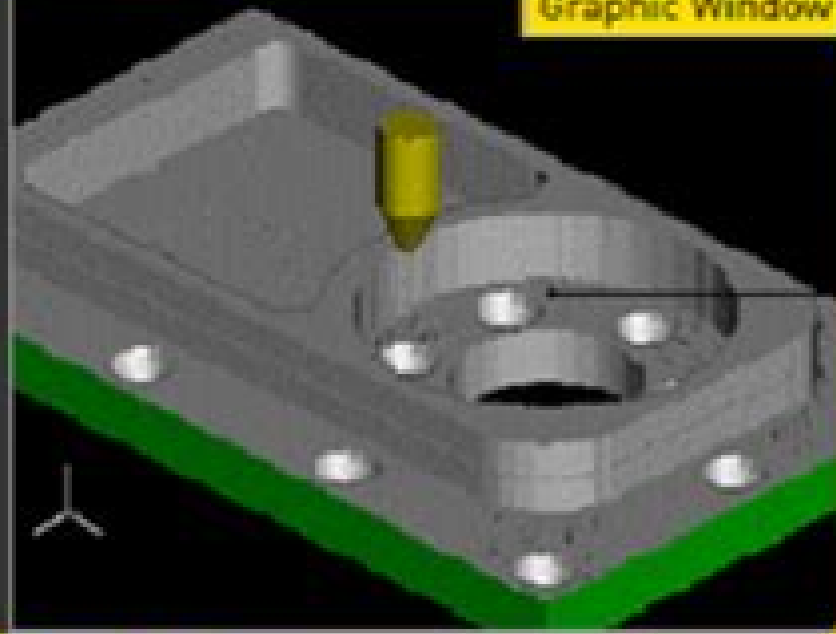

```

1 00000 L/INC.MER-020.0 3
2 02000 0000.1200.00 3
3 03110 00 000.000 05.000.00 05.000.00 05.000.00 05.000.00 05.000.00 05.000.00 05.000.00 05.000.00
4 100 3
5 03040 010.00 0.00 0.000.0000 0.000.0000 0.000.0000 0.000.0000 0.000.0000 0.000.0000 0.000.0000 0.000.0000
6
7 04200 01.00 00.00 00.00 3
8 04300 007.0 003.00000 000.000 000.000 000.000 000.000 000.000 000.000 000.000 000.000 000.000
9 00.00 00.00 01.00 00.00 3
10 04300 009.00000 0.00000 0.00000 000.000 000.000 000.000 000.000 000.000 000.000 000.000 000.000
11 04300 3
12
13 04300 01.00 00.00 00.00 3
14 04300 007.0 003.00000 000.000 000.000 000.000 000.000 000.000 000.000 000.000 000.000 000.000
15 04300 009.00000 0.00000 0.00000 000.000 000.000 000.000 000.000 000.000 000.000 000.000 000.000
16
17 04300 3
18 000 3

```

### Program Window

00 PROGRAM NUMBER

RECALL	START	FEEDS	SINGLE	STOP	PAUSE	GRASP	ENTER	FLYBY	GOBY	+
--------	-------	-------	--------	------	-------	-------	-------	-------	------	---

# Ge Fanuc Manual Guide Programming

**Andrzej Kwiecien, Piotr Gaj, Piotr Stera**

## **Ge Fanuc Manual Guide Programming:**

Instrument Engineers' Handbook, Volume Two Bela G. Liptak, 2018-10-08 The latest update to Bela Liptak's acclaimed bible of instrument engineering is now available. Retaining the format that made the previous editions bestsellers in their own right, the fourth edition of *Process Control and Optimization* continues the tradition of providing quick and easy access to highly practical information. The authors are practicing engineers, not theoretical people from academia, and their trenchant advice has been repeatedly tested in real life applications. Expanded coverage includes descriptions of overseas manufacturer's products and concepts, model based optimization in control theory, new major inventions and innovations in control valves, and a full chapter devoted to safety. With more than 2000 graphs, figures, and tables, this all-inclusive encyclopedic volume replaces an entire library with one authoritative reference. The fourth edition brings the content of the previous editions completely up to date, incorporates the developments of the last decade, and broadens the horizons of the work from an American to a global perspective. Bela G. Liptak speaks on Post Oil Energy Technology on the AT T Tech Channel.

**Instrument Engineers' Handbook, Volume Three** Bela G. Liptak, 2002-06-26 *Instrument Engineers Handbook Third Edition Volume Three: Process Software and Digital Networks* provides an in-depth state-of-the-art review of existing and evolving digital communications and control systems. While the book highlights the transportation of digital information by buses and networks, the total coverage doesn't stop there. It describes **The Journeyman's Guide to Cnc Machines** Bryan Hurst, 2006-06-01 The Guide provides instruction in ISO code programming for Turning. Included are examples that will give an understanding of the principles to apply to any machine and control. Also featured are GE Fanuc and Siemens Controls. The Guide lists functions and codes under the reference JG and provides space to include data for specific machines and controls. Extensive examples show how to programme the options and features. Component drawings have metric and imperial dimensions; simply substitute the dimensions with those of the system of your choice. The Guide is your starting point; use the instructions and suggestions to build your own unique, evolvable folder from here, creating an invaluable personal handbook.

**CNC Programming Handbook** Peter Smid, 2003 Comes with a CD-ROM packed with a variety of problem-solving projects. *SME Technical Paper* Society of Manufacturing Engineers, 2002 *The National Guide to Educational Credit for Training Programs* American Council on Education, 2005 Highlights over 6,000 educational programs offered by business, labor unions, schools, training suppliers, professional and voluntary associations, and government agencies. *Machinery*, 2004 Manufacturing Engineering, 2008 **Instrumentation & Control Systems**, 1999 **Control Engineering**, 1995 *Instrumentation and automatic control systems* *Technician's Guide to Programmable Controllers* Richard A. Cox, 2001 *Technician's Guide to Programmable Controllers 4E* takes a systematic approach, enabling readers without prior knowledge to gain a comprehensive understanding of what a programmable logic controller is, how it works, plus how it is programmed and installed. Numerous and varied troubleshooting techniques are also introduced, making this book a valuable

reference for professional maintenance electricians and plant engineers Fully updated the fourth edition now reflects use of personal computers for programming devices including detailed programming information on both the Allen Bradley SLC 500 and the MicroLogix family of programmable logic controllers

**Computer Networks** Andrzej Kwiecien, Piotr Gaj, Piotr Stera, 2009-06-07 The continuous and very intense development of IT has resulted in the fast development of computer networks Computer networks as well as the entire field of IT are subject to constant change triggered by the general technological advancement and the influence of new IT technologies These methods and tools of designing and modeling computer networks are becoming more advanced Above all the scope of their application is growing thanks to for example the results of new research and because of new proposals of application which not long ago were not even taken into consideration These new applications stimulate the development of scientific research as the broader application of system solutions based on computer networks results in a wide range of both theoretical and practical problems This book proves that and the contents of its chapters concern a variety of topics and issues Generally speaking the contents can be divided into several subject groups The first group of contributions concerns new technologies applied in computer networks particularly those related to nano molecular and quantum technology

**Regional Industrial Buying Guide**, 1996 *Power Transmission Design*, 1989 *Smart Structures and Materials*, 1995 *Twin Plant News*, 2004 **Chilton's I & C S**, 1992

**Programmable Logic Controllers** John W. Webb, Ronald A. Reis, 1999 Useful for an undergraduate level course on PLCs or Electronic Controls this book provides coverage on programmable logic controllers It discusses applications for each PLC function and includes an array of examples and problems that help students achieve an understanding of PLCs

**Control Solutions International**, 2003 **Thomas Register of American Manufacturers**, 2002 This basic source for identification of U S manufacturers is arranged by product in a large multi volume set Includes Products services Company profiles and Catalog file

Recognizing the exaggeration ways to acquire this ebook **Ge Fanuc Manual Guide Programming** is additionally useful. You have remained in right site to start getting this info. acquire the Ge Fanuc Manual Guide Programming associate that we come up with the money for here and check out the link.

You could purchase guide Ge Fanuc Manual Guide Programming or acquire it as soon as feasible. You could speedily download this Ge Fanuc Manual Guide Programming after getting deal. So, following you require the books swiftly, you can straight get it. Its hence entirely easy and so fats, isnt it? You have to favor to in this make public

<https://staging.conocer.cide.edu/book/publication/HomePages/Guide%20To%20Hazardous%20Materials%20Waste%20Mgmt.pdf>

## **Table of Contents Ge Fanuc Manual Guide Programming**

1. Understanding the eBook Ge Fanuc Manual Guide Programming
  - The Rise of Digital Reading Ge Fanuc Manual Guide Programming
  - Advantages of eBooks Over Traditional Books
2. Identifying Ge Fanuc Manual Guide Programming
  - Exploring Different Genres
  - Considering Fiction vs. Non-Fiction
  - Determining Your Reading Goals
3. Choosing the Right eBook Platform
  - Popular eBook Platforms
  - Features to Look for in an Ge Fanuc Manual Guide Programming
  - User-Friendly Interface
4. Exploring eBook Recommendations from Ge Fanuc Manual Guide Programming
  - Personalized Recommendations
  - Ge Fanuc Manual Guide Programming User Reviews and Ratings
  - Ge Fanuc Manual Guide Programming and Bestseller Lists

5. Accessing Ge Fanuc Manual Guide Programming Free and Paid eBooks
  - Ge Fanuc Manual Guide Programming Public Domain eBooks
  - Ge Fanuc Manual Guide Programming eBook Subscription Services
  - Ge Fanuc Manual Guide Programming Budget-Friendly Options
6. Navigating Ge Fanuc Manual Guide Programming eBook Formats
  - ePub, PDF, MOBI, and More
  - Ge Fanuc Manual Guide Programming Compatibility with Devices
  - Ge Fanuc Manual Guide Programming Enhanced eBook Features
7. Enhancing Your Reading Experience
  - Adjustable Fonts and Text Sizes of Ge Fanuc Manual Guide Programming
  - Highlighting and Note-Taking Ge Fanuc Manual Guide Programming
  - Interactive Elements Ge Fanuc Manual Guide Programming
8. Staying Engaged with Ge Fanuc Manual Guide Programming
  - Joining Online Reading Communities
  - Participating in Virtual Book Clubs
  - Following Authors and Publishers Ge Fanuc Manual Guide Programming
9. Balancing eBooks and Physical Books Ge Fanuc Manual Guide Programming
  - Benefits of a Digital Library
  - Creating a Diverse Reading Collection Ge Fanuc Manual Guide Programming
10. Overcoming Reading Challenges
  - Dealing with Digital Eye Strain
  - Minimizing Distractions
  - Managing Screen Time
11. Cultivating a Reading Routine Ge Fanuc Manual Guide Programming
  - Setting Reading Goals Ge Fanuc Manual Guide Programming
  - Carving Out Dedicated Reading Time
12. Sourcing Reliable Information of Ge Fanuc Manual Guide Programming
  - Fact-Checking eBook Content of Ge Fanuc Manual Guide Programming
  - Distinguishing Credible Sources
13. Promoting Lifelong Learning

- Utilizing eBooks for Skill Development
  - Exploring Educational eBooks
14. Embracing eBook Trends
- Integration of Multimedia Elements
  - Interactive and Gamified eBooks

### **Ge Fanuc Manual Guide Programming Introduction**

Free PDF Books and Manuals for Download: Unlocking Knowledge at Your Fingertips In today's fast-paced digital age, obtaining valuable knowledge has become easier than ever. Thanks to the internet, a vast array of books and manuals are now available for free download in PDF format. Whether you are a student, professional, or simply an avid reader, this treasure trove of downloadable resources offers a wealth of information, conveniently accessible anytime, anywhere. The advent of online libraries and platforms dedicated to sharing knowledge has revolutionized the way we consume information. No longer confined to physical libraries or bookstores, readers can now access an extensive collection of digital books and manuals with just a few clicks. These resources, available in PDF, Microsoft Word, and PowerPoint formats, cater to a wide range of interests, including literature, technology, science, history, and much more. One notable platform where you can explore and download free Ge Fanuc Manual Guide Programming PDF books and manuals is the internet's largest free library. Hosted online, this catalog compiles a vast assortment of documents, making it a veritable goldmine of knowledge. With its easy-to-use website interface and customizable PDF generator, this platform offers a user-friendly experience, allowing individuals to effortlessly navigate and access the information they seek. The availability of free PDF books and manuals on this platform demonstrates its commitment to democratizing education and empowering individuals with the tools needed to succeed in their chosen fields. It allows anyone, regardless of their background or financial limitations, to expand their horizons and gain insights from experts in various disciplines. One of the most significant advantages of downloading PDF books and manuals lies in their portability. Unlike physical copies, digital books can be stored and carried on a single device, such as a tablet or smartphone, saving valuable space and weight. This convenience makes it possible for readers to have their entire library at their fingertips, whether they are commuting, traveling, or simply enjoying a lazy afternoon at home. Additionally, digital files are easily searchable, enabling readers to locate specific information within seconds. With a few keystrokes, users can search for keywords, topics, or phrases, making research and finding relevant information a breeze. This efficiency saves time and effort, streamlining the learning process and allowing individuals to focus on extracting the information they need. Furthermore, the availability of free PDF books and manuals fosters a culture of continuous learning. By removing financial barriers, more people can access educational resources and pursue lifelong

learning, contributing to personal growth and professional development. This democratization of knowledge promotes intellectual curiosity and empowers individuals to become lifelong learners, promoting progress and innovation in various fields. It is worth noting that while accessing free Ge Fanuc Manual Guide Programming PDF books and manuals is convenient and cost-effective, it is vital to respect copyright laws and intellectual property rights. Platforms offering free downloads often operate within legal boundaries, ensuring that the materials they provide are either in the public domain or authorized for distribution. By adhering to copyright laws, users can enjoy the benefits of free access to knowledge while supporting the authors and publishers who make these resources available. In conclusion, the availability of Ge Fanuc Manual Guide Programming free PDF books and manuals for download has revolutionized the way we access and consume knowledge. With just a few clicks, individuals can explore a vast collection of resources across different disciplines, all free of charge. This accessibility empowers individuals to become lifelong learners, contributing to personal growth, professional development, and the advancement of society as a whole. So why not unlock a world of knowledge today? Start exploring the vast sea of free PDF books and manuals waiting to be discovered right at your fingertips.

### **FAQs About Ge Fanuc Manual Guide Programming Books**

How do I know which eBook platform is the best for me? Finding the best eBook platform depends on your reading preferences and device compatibility. Research different platforms, read user reviews, and explore their features before making a choice. Are free eBooks of good quality? Yes, many reputable platforms offer high-quality free eBooks, including classics and public domain works. However, make sure to verify the source to ensure the eBook credibility. Can I read eBooks without an eReader? Absolutely! Most eBook platforms offer webbased readers or mobile apps that allow you to read eBooks on your computer, tablet, or smartphone. How do I avoid digital eye strain while reading eBooks? To prevent digital eye strain, take regular breaks, adjust the font size and background color, and ensure proper lighting while reading eBooks. What the advantage of interactive eBooks? Interactive eBooks incorporate multimedia elements, quizzes, and activities, enhancing the reader engagement and providing a more immersive learning experience. Ge Fanuc Manual Guide Programming is one of the best book in our library for free trial. We provide copy of Ge Fanuc Manual Guide Programming in digital format, so the resources that you find are reliable. There are also many Ebooks of related with Ge Fanuc Manual Guide Programming. Where to download Ge Fanuc Manual Guide Programming online for free? Are you looking for Ge Fanuc Manual Guide Programming PDF? This is definitely going to save you time and cash in something you should think about. If you trying to find then search around for online. Without a doubt there are numerous these available and many of them have the freedom. However without doubt you receive whatever you purchase. An alternate way to get ideas is always to check



another Ge Fanuc Manual Guide Programming. This method for see exactly what may be included and adopt these ideas to your book. This site will almost certainly help you save time and effort, money and stress. If you are looking for free books then you really should consider finding to assist you try this. Several of Ge Fanuc Manual Guide Programming are for sale to free while some are payable. If you arent sure if the books you would like to download works with for usage along with your computer, it is possible to download free trials. The free guides make it easy for someone to free access online library for download books to your device. You can get free download on free trial for lots of books categories. Our library is the biggest of these that have literally hundreds of thousands of different products categories represented. You will also see that there are specific sites catered to different product types or categories, brands or niches related with Ge Fanuc Manual Guide Programming. So depending on what exactly you are searching, you will be able to choose e books to suit your own need. Need to access completely for Campbell Biology Seventh Edition book? Access Ebook without any digging. And by having access to our ebook online or by storing it on your computer, you have convenient answers with Ge Fanuc Manual Guide Programming To get started finding Ge Fanuc Manual Guide Programming, you are right to find our website which has a comprehensive collection of books online. Our library is the biggest of these that have literally hundreds of thousands of different products represented. You will also see that there are specific sites catered to different categories or niches related with Ge Fanuc Manual Guide Programming So depending on what exactly you are searching, you will be able to choose ebook to suit your own need. Thank you for reading Ge Fanuc Manual Guide Programming. Maybe you have knowledge that, people have search numerous times for their favorite readings like this Ge Fanuc Manual Guide Programming, but end up in harmful downloads. Rather than reading a good book with a cup of coffee in the afternoon, instead they juggled with some harmful bugs inside their laptop. Ge Fanuc Manual Guide Programming is available in our book collection an online access to it is set as public so you can download it instantly. Our digital library spans in multiple locations, allowing you to get the most less latency time to download any of our books like this one. Merely said, Ge Fanuc Manual Guide Programming is universally compatible with any devices to read.

### **Find Ge Fanuc Manual Guide Programming :**

[guide to hazardous materials waste mgmt](#)

[guide to electronic communication](#)

[guide to ancient and historic wales glamorgan and gwent](#)

[guide to japanese prose asian literature bibliography series](#)

[guide to homebuilt rotorcraft](#)

**guia completa de new york**

**guide to oregons rocky intertidal areas**

guide terrestre ou la terre et ses singes

grunsee roman

guia ma

*guide to prescription and over-the-counter drugs brand-name drugs generic drugs vitamins minerals food additives*

**guatemala the land of the quetzal**

guide to modern cooking

guess who fish face

**guide to commercial radio journalism**

**Ge Fanuc Manual Guide Programming :**

**jack straight from the gut welch jack byrne john a amazon de** - Dec 28 2021

web jack straight from the gut welch jack byrne john a isbn 9780446690683 kostenloser versand für alle bücher mit versand und verkauf duch amazon

*jack straight from the gut kindle edition amazon com* - Nov 07 2022

web oct 1 2003 as an autobiography jack straight from the gut is a pleasure to read welch s a type straight talking personality comes through with the help of co author john a byrne in a natural down to earth writing style jack welch s rise from small town irish immigrant roots to chairman of general electric is one of the most engaging and inspiring

**jack straight from the gut amazon co uk welch jack byrne** - Jan 09 2023

web buy jack straight from the gut illustrated by welch jack byrne john a isbn 9780446690683 from amazon s book store everyday low prices and free delivery on eligible orders

*jack straight from the gut the new york times* - Oct 06 2022

web oct 14 2001 first chapter jack straight from the gut by jack welch with john a byrne oct 14 2001 it was the final hockey game of a lousy season we had won the first three games in my senior year

*jack straight from the gut pdf summary jack welch 12min* - Jan 29 2022

web mar 12 2019 jack straight from the gut pdf summary by jack welch explains why becoming a ceo was not on jack welch s agenda from the start to find more about it read more book summaries and check our nuggets visual quotes from books a really good story for an autobiography

**jack straight from the gut jack welch john a byrne google** - Mar 11 2023

web headline 2003 chief executive officers 480 pages jack welch is acknowledged by many as the greatest corporate leader

of the 20th century when he first became ceo of general electric in 1981 the company was worth 12 billion

**jack straight from the gut jack welch john a byrne google** - May 13 2023

web oct 1 2003 jack straight from the gut the most widely respected ceo in america looks back on his brilliant career at general electric and reveals his personal business philosophy and unique managerial style nearly 20 years ago former general electric ceo reg jones walked into jack welch s office and wrapped him in a bear hug

**jack welch straight from the gut success** - May 01 2022

web jun 16 2014 a meaningful purpose it s vintage welch throughout his career as he increased the value of ge by an eye popping 4 000 percent he was known as a blunt to a fault unconventional leader while

**jack straight from the gut jack welch john a byrne google books** - Feb 10 2023

web this book is laced with refreshing interludes such as a short reflection on golf that capture jack s competitiveness and the importance of friendship in his life jack straight from the gut is both a business classic and a deeply personal journey filled with passion and a sheer lust for life

jack straight from the gut by jack welch goodreads - Jul 15 2023

web jan 1 2001 jack straight from the gut first published in the united states in 2001 autobiographical books this book introduces jack welch s life experience and heart course for most of his life jack welch born in salem massachusetts in november 1935 died in march 2020

**jack straight from the gut jack welch john a byrne google books** - Jun 14 2023

web oct 1 2003 in this remarkable autobiography a classic business book and runaway new york times bestseller now updated with a new afterword by the author jack welch takes us on the rough and tumble ride

*jack straight from the gut amazon com* - Aug 04 2022

web as an autobiography jack straight from the gut is a pleasure to read welch s a type straight talking personality comes through with the help of co author john a byrne in a natural down to earth writing style jack welch s rise from small town irish immigrant roots to chairman of general electric is one of the most engaging and inspiring

**jack straight from the gut paperback amazon singapore** - Sep 05 2022

web verified purchase jack welch s life has been about excellence winning and having fun his autobiography jack straight from the gut tells how he rose from small town roots to become ceo of general electric arguably the greatest corporation in america and the world at the end of the 20th century

jack straight from the gut by jack welch publishers weekly - Feb 27 2022

web jack straight from the gut jack welch with john a byrne read by welch time warner audio 25 98 0pp isbn 978 1 58621 172 1 it doesn t matter whether you love or hate jack

**jack straight from the gut welch jack byrne john a** - Apr 12 2023

web jack straight from the gut welch jack byrne john a amazon com tr Çerez tercihlerinizi seçin Çerez bildirimimizde detaylandırıldığı üzere satın alım yapmanızı sağlamak alışveriş deneyiminizi geliştirmek ve hizmetlerimizi sunmak için gerekli olan çerezleri ve benzer araçları kullanıyoruz

**jack straight from the gut welch jack byrne john a** - Dec 08 2022

web in 2001 he wrote his 1 new york times and also international best selling autobiography jack straight from the gut jack recently launched the jack welch management institute at strayer university a unique online mba and certificate program aimed at giving students globally and at every career level the tools to transform their lives and

jack straight from the gut by jack welch john a byrne - Jul 03 2022

web oct 1 2003 in jack straight from the gut welch is both storyteller and coach using his exceptional career as the backdrop to share his thoughts on what it takes to be a great leader part management text part page turner jack shows how the man widely regarded as the finest corporate executive of his generation built his business and his reputation

**jack straight from the gut welch jack byrne john a** - Aug 16 2023

web in 2001 he wrote his 1 new york times and also international best selling autobiography jack straight from the gut jack recently launched the jack welch management institute at strayer university a unique online mba and certificate program aimed at giving students globally and at every career level the tools to transform their lives and

**buy jack straight from the gut book online at low prices in** - Jun 02 2022

web oct 1 2003 as an autobiography jack straight from the gut is a pleasure to read welch s a type straight talking personality comes through with the help of co author john a byrne in a natural down to earth writing style jack welch s rise from small town irish immigrant roots to chairman of general electric is one of the most engaging and inspiring

straight from the gut welch jack 1935 2020 archive org - Mar 31 2022

web jack straight from the gut by welch jack 1935 2020 publication date 2003 topics welch jack 1935 2020 general electric company biography general electric company chief executive officers united states biography chief executive officers united states publisher

**chemistry lesson 11 1 flashcards quizlet** - Feb 11 2023

web chemistry 12th edition answers to chapter 11 chemical reactions 11 assessment page 377 48 including work step by step written by community members like you

**samacheer kalvi guru 11th chemistry guide book back answers** - Oct 27 2021

web mar 26 2023 solved long answer type and short answer type questions and numerical problems authentic simple to the point and modern account of each and every topic

[11 1 describing chemical reactions workbook answers](#) - Oct 07 2022

web ch 11 chemical reactions workbook answers list of ebooks and manuals about ch 11 chemical reactions workbook answers

**ch 11 chemical reactions workbook answers harvard university** - Jun 15 2023

web chemical reactions 321 print guided reading and study workbook section 11 1 core teaching resources section 11 1 review small scale chemistry laboratory manual

**ch 11 chemical reactions workbook answers pdf gccca** - Sep 25 2021

**ch 11 chemical reactions workbook answers pdf free** - Jan 30 2022

web get those all we meet the expense of year 11 chemical reactions workbook answer and numerous books collections from fictions to scientific research in any way among

*chemistry 11 1st edition solutions and answers quizlet* - Aug 17 2023

web our resource for chemistry 11 includes answers to chapter exercises as well as detailed information to walk you through the process step by step with expert solutions for

*ch 11 chemical reactions workbook answers andalan bounche* - May 02 2022

web chemistry worksheets for class 11 chemistry chapter wise below is the most comprehensive collection of cbse ncert worksheets for class 11 chemistry that you

**cbse worksheets for class 11 chemistry** - Feb 28 2022

web pages of ch 11 chemical reactions workbook answers pdf a interesting function of literary elegance that pulses with raw emotions lies an remarkable journey waiting to be

**pearson chemistry 9780132525763 solutions and answers** - Apr 13 2023

web a chemical change in which two or more substances react to form a single new substance combustion reaction a chemical reaction that occurs when a substance reacts with

**ch 11 chemical reactions workbook answers thebookee net** - Sep 06 2022

web aug 24 2023 ch 11 chemical reactions workbook answers 1 23 downloaded from uniport edu ng on august 24 2023 by guest ch 11 chemical reactions workbook

*class 11 chemistry worksheets byju s* - Apr 01 2022

web jul 10 2019 by practising ncert cbse class 11 chemistry worksheet students can improve their problem solving skills helps to develop the subject knowledge in a simple

*chapter 11 chemical reactions 11 assessment page 377 48* - Jan 10 2023

web a representation of a chemical reaction the formulas of the reactants left are connected by an arrow with the formulas of the products on right skeleton equation a chemical

*11 1 describing chemical reactions 11* - May 14 2023

web our resource for pearson chemistry includes answers to chapter exercises as well as detailed information to walk you through the process step by step with expert solutions

**ch 11 chemical reactions workbook answers pdf uniport edu** - Jul 04 2022

web evaluation ch 11 chemical reactions workbook answers what you as soon as to read ch 11 chemical reactions workbook answers downloaded from

**ch 11 chemical reactions workbook answers pdf uniport edu** - Aug 05 2022

web apr 30 2023 ch 11 chemical reactions workbook answers 2 20 downloaded from uniport edu ng on april 30 2023 by guest next subject area homework problems directly

**year 11 chemical reactions workbook answer** - Dec 29 2021

web jul 18 2021 we have provided below free printable class 11 chemistry worksheets for download in pdf the worksheets have been designed based on the latest ncert book

**chemistry guided reading and study workbook** - Jul 16 2023

web a wealth of unique study tools help students organize and understand the substantial information presented in this course and in the sixth edition the themes of

**pearson chemistry chapter 11 flashcards quizlet** - Dec 09 2022

web terms in this set 18 chemical equation an expression representing a chemical reaction the formulas of the reactants on the left are connected by an arrow with the formulas for

ch 11 chemical reactions workbook answers 2022 - Jun 03 2022

web ch 11 chemical reactions workbook answers 3 3 emphasizing the concept of chemical organization a closed and self maintaining set of chemicals and surveys a range of

**class 11 chemistry worksheets download pdf with solutions** - Nov 27 2021

web feb 17 2021 tamilnadu state board samacheer kalvi 11th chemistry book volume 2 solutions chapter 8 physical and chemical equilibrium chapter 9 solutions chapter

**chapter 11 chemical reactions vocab flashcards quizlet** - Mar 12 2023

web chemistry lesson 11 1 to write a word equation write the names of the reactants to the left of the arrow separated by plus signs write the names of the product to the right of the

chapter 11 1 pearson chemistry flashcards quizlet - Nov 08 2022

web chemistry 12th edition answers to chapter 11 chemical reactions 11 11 1 describing chemical reactions chemistry you everyday matter think

*complete chemistry for cambridge igcse answers* - Jul 24 2022

web 0620 igcse chemistry answers topic wise segregation question bank paper 2 online detailed solved solution question bank papers download complete chemistry for cambridge igcse answers rosemarie gallagher paul ingram buy access to complete books solutions for 20 1 states of matter 2 separating substances

**complete chemistry for cambridge secondary 1 student book** - May 02 2023

web mar 14 2013 complete chemistry for cambridge secondary 1 covers all three years of cambridge secondary 1 chemistry in the same book flowing smoothly from one stage to the next regular

**cambridge igcse o level complete chemistry kerboodle** - May 22 2022

web dec 5 2022 written by teachers and cambridge assessment experts these complete chemistry for igcse o level kerboodle resources provide authoritative digital support for cambridge chemistry for igcse and have been developed to fully match the cambridge igcse chemistry syllabus for first examination in 2023

*complete chemistry for cambridge secondary 1 student book* - Apr 01 2023

web nov 1 2014 it is the best preparation for our bestselling complete science for cambridge igcse course facilitating seamless progression from cambridge secondary 1 stage 9 right into complete chemistry for cambridge igcse complete chemistry for cambridge secondary 1 covers all three years of cambridge secondary 1 chemistry

**complete chemistry for cambridge igcse oxford university press** - Jul 04 2023

web secondary teachers complete chemistry for cambridge igcse end of section questions diagnostic questions core syllabus diagnostic questions extended syllabus answers to all diagnostic questions revision checklists practice papers sample answers exam preparation

**complete chemistry for secondary 1 by philippa gardom hulme** - Jun 03 2023

web what is scribd documents 80 5 3k views 301 pages complete chemistry for secondary 1 by philippa gardom hulme uploaded by mahiman vaishnav ai enhanced title chemistry textbook for 7 8 9 grade copyright all rights reserved available formats download as pdf txt or read online from scribd flag for inappropriate content save

**complete chemistry cambridge secondary 1 fliphtml5** - Oct 07 2023

web jun 21 2021 check pages 1 50 of complete chemistry cambridge secondary 1 in the flip pdf version complete chemistry cambridge secondary 1 was published by adlin saroni on 2021 06 21 find more similar flip pdfs like complete chemistry cambridge secondary 1 download complete chemistry cambridge secondary 1

**complete chemistry for cambridge secondary 1 teacher pack** - Nov 27 2022

web get instant access to our step by step complete chemistry for cambridge secondary 1 teacher pack solutions manual our solution manuals are written by chegg experts so you can be assured of the highest quality

[complete chemistry for cambridge secondary 1](#) - Aug 25 2022

web complete chemistry for cambridge secondary 1 workbook solutions pdf free download worked answers detail igcse ib

[complete chemistry of cambridge igcse pdf google drive](#) - Aug 05 2023

web view details request a review learn more

**free download complete chemistry for cambridge igcse by** - Dec 29 2022

web complete chemistry for cambridge igcse authors rose marie gallagher paul ingram table of contents chapter 1 states of matter 1 1 everything is made of particles 1 2 solids liquids and gases 1 3 the particles in solids liquids and gases 1 4 a closer look at gases checkup on chapter 1 chapter 2 separating substances 2 1 mixtures

*complete chemistry for cambridge secondary 1 student book* - Feb 28 2023

web complete chemistry for cambridge secondary 1 covers all three years of cambridge secondary 1 chemistry in the same book flowing smoothly from one stage to the next regular revision and extension exercises will help consolidate learning and then stretch and challenge students to reach the next level

*cambridge igcse chemistry 0620* - Sep 25 2022

web cambridge igcse chemistry third edition collins this course provides complete coverage of the updated cambridge igcse chemistry syllabus and is packed full of questions in depth content practical investigative skills features and more read more on the collins website

**complete chemistry for cambridge igcse r online student book** - Mar 20 2022

web the best selling complete chemistry for cambridge igcse r third edition online student book is matched to the previous igcse chemistry syllabus last examination 2022 essential chemistry for cambridge secondary 1 stag 28 95 order now qce surfing chemistry unit 2 49 95 order now pearson chemistry qld 11 sb r

**complete chemistry cambridge secondary 1 fliphtml5** - Sep 06 2023

web jun 21 2021 this book has been written to help you study chemistry at all three stages of cambridge secondary 1 most of the pages in this book work like this 1 1 states of matter objective the particle theory of matter compressing solids liquids and gases use ideas about particles what do the substances in the pictures have in common

*complete chemistry for cambridge secondary 1 workbook* - Jun 22 2022

web aug 23 2022 interested in flipbooks about complete chemistry for cambridge secondary 1 workbook check more flip ebooks related to complete chemistry for cambridge secondary 1 workbook of intertu education share complete chemistry for cambridge secondary 1 workbook everywhere for free



**complete revision notes of introduction to organic chemistry for** - Apr 20 2022

web nov 5 2023 tes global ltd is registered in england company no 02017289 with its registered office at building 3 st paul s place norfolk street sheffield s1 2je the following sub topics are covered in this section 1 homologous series 2 formulae in organic chemistry 3 isomerism 4 functional groups 5

**complete chemistry for cambridge igcserg 2nd edition quizlet** - Jan 30 2023

web complete chemistry for cambridge igcserg 2nd edition isbn 9780199138784 gallagher textbook solutions verified chapter 1 states of matter section 1 1 everything is made of particles section 1 2 solids liquids and gases section 1 3 the particles in solids liquids and gases section 1 4 checkup on chapter 1 exercise 1 exercise 2 exercise 3

*complete chemistry for cambridge igcse oxford university press* - Feb 16 2022

web a suite of mock cambridge igcse papers made up of real questions from past papers for more exam practice and preparation go to the complete chemistry for cambridge igcse kerboodle syllabus matching grid for complete chemistry for cambridge igcse

**cambridge lower secondary complete chemistry student book second** - Oct 27 2022

web oct 14 2021 the cambridge lower secondary complete chemistry student book builds a solid foundation in lower secondary chemistry through a rigorous separate science approach which stretches students to prepare them for the step up to igcse features fully covers the chemistry requirements of the cambridge lower secondary