

TRANSMISSION ASSEMBLY

VQ40DE 4WD Models

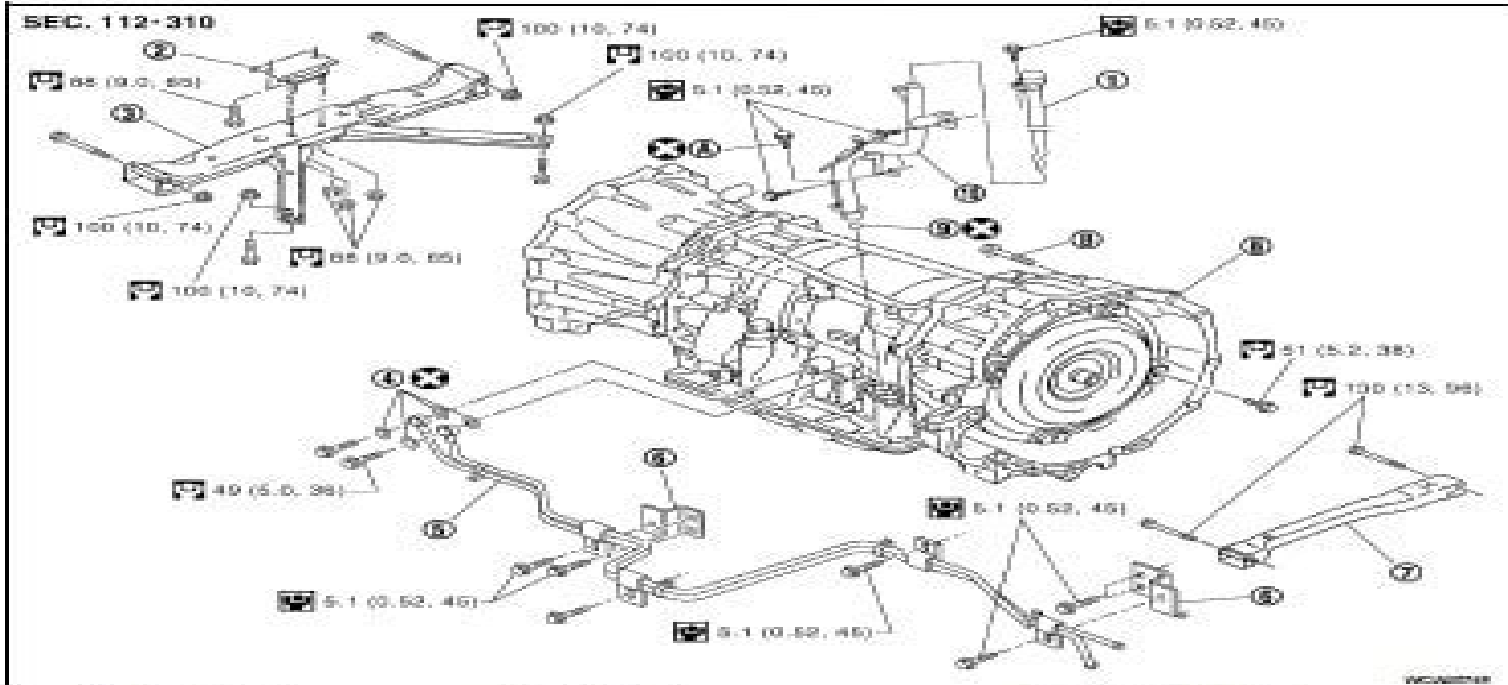

- | | | |
|------------------------------|--------------------------|---------------------------|
| 1. A/T fluid indicator | 2. Insulator | 3. A/T crossmember |
| 4. Copper washers | 5. A/T fluid cooler tube | 6. Bracket |
| 7. Front crossmember | 8. Transmission assembly | 9. O-ring |
| 10. A/T fluid indicator pipe | A. Self-sealing bolt | B. Refer to installation. |

- A
- B
- AT**
- D
- E
- F
- G
- H
- I
- J
- K
- L
- M

Manual Nissan Frontier 2006

J Rink



Manual Nissan Frontier 2006:

Embark on a transformative journey with is captivating work, **Manual Nissan Frontier 2006** . This enlightening ebook, available for download in a convenient PDF format , invites you to explore a world of boundless knowledge. Unleash your intellectual curiosity and discover the power of words as you dive into this riveting creation. Download now and elevate your reading experience to new heights .

<https://staging.conocer.cide.edu/data/browse/Documents/Mpumalanga%20Memorandum%20Mathematics%20P1%20Grade%2012%20June%202014.pdf>

Table of Contents Manual Nissan Frontier 2006

1. Understanding the eBook Manual Nissan Frontier 2006
 - The Rise of Digital Reading Manual Nissan Frontier 2006
 - Advantages of eBooks Over Traditional Books
2. Identifying Manual Nissan Frontier 2006
 - Exploring Different Genres
 - Considering Fiction vs. Non-Fiction
 - Determining Your Reading Goals
3. Choosing the Right eBook Platform
 - Popular eBook Platforms
 - Features to Look for in an Manual Nissan Frontier 2006
 - User-Friendly Interface
4. Exploring eBook Recommendations from Manual Nissan Frontier 2006
 - Personalized Recommendations
 - Manual Nissan Frontier 2006 User Reviews and Ratings
 - Manual Nissan Frontier 2006 and Bestseller Lists
5. Accessing Manual Nissan Frontier 2006 Free and Paid eBooks
 - Manual Nissan Frontier 2006 Public Domain eBooks
 - Manual Nissan Frontier 2006 eBook Subscription Services

- Manual Nissan Frontier 2006 Budget-Friendly Options
- 6. Navigating Manual Nissan Frontier 2006 eBook Formats
 - ePub, PDF, MOBI, and More
 - Manual Nissan Frontier 2006 Compatibility with Devices
 - Manual Nissan Frontier 2006 Enhanced eBook Features
- 7. Enhancing Your Reading Experience
 - Adjustable Fonts and Text Sizes of Manual Nissan Frontier 2006
 - Highlighting and Note-Taking Manual Nissan Frontier 2006
 - Interactive Elements Manual Nissan Frontier 2006
- 8. Staying Engaged with Manual Nissan Frontier 2006
 - Joining Online Reading Communities
 - Participating in Virtual Book Clubs
 - Following Authors and Publishers Manual Nissan Frontier 2006
- 9. Balancing eBooks and Physical Books Manual Nissan Frontier 2006
 - Benefits of a Digital Library
 - Creating a Diverse Reading Collection Manual Nissan Frontier 2006
- 10. Overcoming Reading Challenges
 - Dealing with Digital Eye Strain
 - Minimizing Distractions
 - Managing Screen Time
- 11. Cultivating a Reading Routine Manual Nissan Frontier 2006
 - Setting Reading Goals Manual Nissan Frontier 2006
 - Carving Out Dedicated Reading Time
- 12. Sourcing Reliable Information of Manual Nissan Frontier 2006
 - Fact-Checking eBook Content of Manual Nissan Frontier 2006
 - Distinguishing Credible Sources
- 13. Promoting Lifelong Learning
 - Utilizing eBooks for Skill Development
 - Exploring Educational eBooks
- 14. Embracing eBook Trends

- Integration of Multimedia Elements
- Interactive and Gamified eBooks

Manual Nissan Frontier 2006 Introduction

In today's digital age, the availability of Manual Nissan Frontier 2006 books and manuals for download has revolutionized the way we access information. Gone are the days of physically flipping through pages and carrying heavy textbooks or manuals. With just a few clicks, we can now access a wealth of knowledge from the comfort of our own homes or on the go. This article will explore the advantages of Manual Nissan Frontier 2006 books and manuals for download, along with some popular platforms that offer these resources. One of the significant advantages of Manual Nissan Frontier 2006 books and manuals for download is the cost-saving aspect. Traditional books and manuals can be costly, especially if you need to purchase several of them for educational or professional purposes. By accessing Manual Nissan Frontier 2006 versions, you eliminate the need to spend money on physical copies. This not only saves you money but also reduces the environmental impact associated with book production and transportation. Furthermore, Manual Nissan Frontier 2006 books and manuals for download are incredibly convenient. With just a computer or smartphone and an internet connection, you can access a vast library of resources on any subject imaginable. Whether you're a student looking for textbooks, a professional seeking industry-specific manuals, or someone interested in self-improvement, these digital resources provide an efficient and accessible means of acquiring knowledge. Moreover, PDF books and manuals offer a range of benefits compared to other digital formats. PDF files are designed to retain their formatting regardless of the device used to open them. This ensures that the content appears exactly as intended by the author, with no loss of formatting or missing graphics. Additionally, PDF files can be easily annotated, bookmarked, and searched for specific terms, making them highly practical for studying or referencing. When it comes to accessing Manual Nissan Frontier 2006 books and manuals, several platforms offer an extensive collection of resources. One such platform is Project Gutenberg, a nonprofit organization that provides over 60,000 free eBooks. These books are primarily in the public domain, meaning they can be freely distributed and downloaded. Project Gutenberg offers a wide range of classic literature, making it an excellent resource for literature enthusiasts. Another popular platform for Manual Nissan Frontier 2006 books and manuals is Open Library. Open Library is an initiative of the Internet Archive, a non-profit organization dedicated to digitizing cultural artifacts and making them accessible to the public. Open Library hosts millions of books, including both public domain works and contemporary titles. It also allows users to borrow digital copies of certain books for a limited period, similar to a library lending system. Additionally, many universities and educational institutions have their own digital libraries that provide free access to PDF books and manuals. These libraries often offer academic texts, research papers, and technical manuals, making them invaluable resources for students.

and researchers. Some notable examples include MIT OpenCourseWare, which offers free access to course materials from the Massachusetts Institute of Technology, and the Digital Public Library of America, which provides a vast collection of digitized books and historical documents. In conclusion, Manual Nissan Frontier 2006 books and manuals for download have transformed the way we access information. They provide a cost-effective and convenient means of acquiring knowledge, offering the ability to access a vast library of resources at our fingertips. With platforms like Project Gutenberg, Open Library, and various digital libraries offered by educational institutions, we have access to an ever-expanding collection of books and manuals. Whether for educational, professional, or personal purposes, these digital resources serve as valuable tools for continuous learning and self-improvement. So why not take advantage of the vast world of Manual Nissan Frontier 2006 books and manuals for download and embark on your journey of knowledge?

FAQs About Manual Nissan Frontier 2006 Books

1. Where can I buy Manual Nissan Frontier 2006 books? Bookstores: Physical bookstores like Barnes & Noble, Waterstones, and independent local stores. Online Retailers: Amazon, Book Depository, and various online bookstores offer a wide range of books in physical and digital formats.
2. What are the different book formats available? Hardcover: Sturdy and durable, usually more expensive. Paperback: Cheaper, lighter, and more portable than hardcovers. E-books: Digital books available for e-readers like Kindle or software like Apple Books, Kindle, and Google Play Books.
3. How do I choose a Manual Nissan Frontier 2006 book to read? Genres: Consider the genre you enjoy (fiction, non-fiction, mystery, sci-fi, etc.). Recommendations: Ask friends, join book clubs, or explore online reviews and recommendations. Author: If you like a particular author, you might enjoy more of their work.
4. How do I take care of Manual Nissan Frontier 2006 books? Storage: Keep them away from direct sunlight and in a dry environment. Handling: Avoid folding pages, use bookmarks, and handle them with clean hands. Cleaning: Gently dust the covers and pages occasionally.
5. Can I borrow books without buying them? Public Libraries: Local libraries offer a wide range of books for borrowing. Book Swaps: Community book exchanges or online platforms where people exchange books.
6. How can I track my reading progress or manage my book collection? Book Tracking Apps: Goodreads, LibraryThing, and Book Catalogue are popular apps for tracking your reading progress and managing book collections. Spreadsheets: You can create your own spreadsheet to track books read, ratings, and other details.

7. What are Manual Nissan Frontier 2006 audiobooks, and where can I find them? Audiobooks: Audio recordings of books, perfect for listening while commuting or multitasking. Platforms: Audible, LibriVox, and Google Play Books offer a wide selection of audiobooks.
8. How do I support authors or the book industry? Buy Books: Purchase books from authors or independent bookstores. Reviews: Leave reviews on platforms like Goodreads or Amazon. Promotion: Share your favorite books on social media or recommend them to friends.
9. Are there book clubs or reading communities I can join? Local Clubs: Check for local book clubs in libraries or community centers. Online Communities: Platforms like Goodreads have virtual book clubs and discussion groups.
10. Can I read Manual Nissan Frontier 2006 books for free? Public Domain Books: Many classic books are available for free as they're in the public domain. Free E-books: Some websites offer free e-books legally, like Project Gutenberg or Open Library.

Find Manual Nissan Frontier 2006 :

[mpumalanga memorandum mathematics p1 grade 12 june 2014](#)

mr wilson s regents mechanical wave review answers

[moulinex juicer instruction manual](#)

[mr wilson regents physics mechanical waves review answers](#)

mr darcys forbidden love english edition

[mourning malice book 7 volume 7](#)

[ms access 2007 manual](#)

[motorola w370 user manual](#)

[ms excel training guide](#)

motorola z6c hard reset

[mpumalanga 2014 geography question papers for grade 11](#)

[mr kennedy chapter 8 grade 11 functions](#)

[mrp maintenance manual](#)

mountain guide salary

[motorola v860 barrage manual](#)

Manual Nissan Frontier 2006 :

[clinical prediction models a practical approach to development](#) - Jul 14 2023

web about this book prediction models are important in various fields including medicine physics meteorology and finance prediction models will become more relevant in the medical field with the increase in knowledge on potential predictors of

clinical prediction models github pages - Apr 30 2022

web jan 20 2023 work in progress this bookdown based website containing the supplementary materials from clinical

prediction models a practical approach to development validation and updating by e w steyerberg 2009

[clinical prediction models a practical approach to development](#) - Oct 05 2022

web contents summary publisher s summary the second edition of this volume provides insight and practical illustrations on how modern statistical concepts and regression methods can be applied in medical prediction problems including diagnostic and prognostic outcomes

clinical prediction models a practical approach to development - Dec 07 2022

web jun 1 2010 vdom dhtml tml clinical prediction models a practical approach to development validation and updating by steyerberg e w omar 2010 biometrics wiley online library

clinical prediction models a practical approach to development - Mar 10 2023

web jan 1 2009 pdf on jan 1 2009 ewout w steyerberg published clinical prediction models a practical approach to development validation and updating find read and cite all the research you need on

clinical prediction models a practical approach to development - Jan 08 2023

web jun 1 2010 clinical prediction models a practical approach to development validation and updating by steyerberg e w omar 2010 biometrics wiley online library biometrics

the importance of predictive modeling for clinical trials webmedy - Dec 27 2021

web nov 14 2021 predict clinical trial outcomes predictive analytics are being used to predict which patients will respond favorably or poorly to a treatment based on their genetic make up age medical history and other information clinical research analysts may also use predictive analytics to detect adverse events during clinical trials by analyzing real

[clinical prediction models a practical approach to development](#) - Aug 03 2022

web introduction applications of prediction models study design for prediction modeling statistical models for prediction overfitting and optimism in prediction models choosing between alternative statistical models missing values case study on dealing with missing values coding of categorical and continuous predictors

clinical prediction models a practical approach to development - Aug 15 2023

web this text presents a practical checklist for development of a valid prediction model including case studies and publicly

available r code and data sets it is appropriate for a grad course on predictive modeling in diagnosis and prognosis for clinical epidemiologists and biostatisticians

clinical prediction models a practical approach to development - Nov 06 2022

web jun 12 2009 clinical prediction models a practical approach to development validation and updating citation mann c j h 2009 clinical prediction models a practical approach to development validation and updating kybernetes vol 38 no 6 doi org 10 1108 k 2009 06738fae 002 download as ris publisher emerald

clinical prediction models - Jul 02 2022

web welcome to this site that supplements the book clinical prediction models prediction models are increasingly relevant in the medical field we witness an increase in biological knowledge on potential predictors of outcome e g on biomarkers increasing access to large data sets and popularity of machine learning methods

clinical prediction models a practical approach to development - Apr 11 2023

web sep 28 2009 in my opinion clinical prediction models provides a very good intermediate level treatment of model development validation and updating applied to medicine it also bridges the gap between basic regression textbooks which do not discuss prediction models in detail and more advanced books on model development which

clinical prediction models a practical approach to development - Sep 04 2022

web jul 22 2019 clinical prediction models a practical approach to development validation and updating ewout w steyerberg springer jul 22 2019 medical 558 pages prediction models are

free download clinical prediction models a practical approach - Feb 26 2022

web mar 8 2020 clinical prediction models a practical approach to development validation and updating statistics for biology and health book detail series statistics for biology and health hardcover publisher springer 2nd ed 2019 edition september 9 2019 language english isbn 10 3030163989 isbn 13 978 3030163983 product

[clinical prediction models a practical approach to development](#) - Jun 13 2023

web may 28 2009 the book also has a nice discussion about the generalizability of prediction models including patterns of invalidity that may be encountered in new settings approaches to modifying and extending a model and comparisons of centers after case mix adjustment by a prediction model

clinical prediction models diagnosis versus prognosis - Jun 01 2022

web apr 1 2021 clinical prediction models play an increasingly important role in contemporary clinical care by informing healthcare professionals patients and their relatives about outcome risks with the aim to facilitate shared medical decision making and improve health outcomes

clinical prediction models a practical approach to development - May 12 2023

web apr 20 2020 clinical prediction models a practical approach to development validation and updating ewout w steyerberg 2019 second edition springer series statistics for biology and health cham springer 558 pages isbn 978 3 030 16398 3 doi org 10 1007 978 3 030 16399 0

[clinical prediction models a practical approach to development](#) - Jan 28 2022

web 2 clinical prediction models a practical approach to development validation and updating statistics for biology and health 2019 11 10 patients biblical series vi the psychology of the flood mattia fornasa transferring clinical *clinical prediction models a practical approach to development* - Feb 09 2023

web apr 20 2020 clinical prediction models a practical approach to development validation and updating steyerberg ewout w 2019 second edition springer

clinical prediction models in psychiatry a systematic review of - Mar 30 2022

web apr 1 2022 prediction models can therefore inform clinical decisions by supporting structured tools e g risk calculators clinical prediction rules that classify patients into discrete subgroups

time off request form kt benefits pdf pdf - May 06 2022

web employee time off request forms with template and web what is a time off request form a time off request form is a document that formally records when an employee asks for time off it includes all the details of the request such as the reason for the absence and the dates the employee will be gone it also includes a spot to indicate if their

employment practices ministry of manpower - May 18 2023

web part time employment entitlements for part time employees in accordance with the employment act including overtime rest days public holidays and leave public holidays entitlement and pay gazetted public holidays holiday pay pay for working on public holidays and time off in lieu responsible re employment

[benefits singapore paid time off vmware](#) - Jun 07 2022

web paid time off paid time off pto is a combination of annual leave and floating days off fdo that allow you to be paid while having time off from work for personal reasons including vacation used for rest recreation or travel scheduled medical appointments taking time out for loved ones

can my employer give me time off instead of overtime pay - Jan 14 2023

web if you are covered under part iv of the employment act your employer cannot substitute overtime pay with time off overtime must be paid at the rate of at least 1 5 times the hourly basic rate of pay

tripartite alliance limited - Nov 12 2022

web the request for fwas will be reviewed periodically some jobs positions e g regular customer facing roles or specific onsite work using specialised equipment may not be suitable for certain fwas both parties should agree that a fwa may need to be

revised or adapted at times and perhaps even discontinued if the mutually agreed goals and
time off request form kt benefits pdf bukuclone ortax org - Dec 13 2022

web time off request form kt benefits pdf upload mia b boyle 2 10 downloaded from bukuclone ortax org on september 16
2023 by mia b boyle methods derivative pricing using jump diffusion with closed form formulas var calculation using extreme
value theory based on a non homogeneous two dimensional poisson process multivariate
[time off request form term 4](#) - Sep 22 2023

web please update the relief team on your time off request for relief planning after completing this request form thank you
employee time off request forms with template and example indeed - Oct 11 2022

web a time off request form is a document that formally records when an employee asks for time off it includes all the details
of the request such as the reason for the absence and the dates the employee will be gone
request for time off application - Aug 21 2023

web please ensure that you have sought support from your reporting officer ro and approval from principal before
completing this form 1 declaration i have read and agreed with the guidelines above 1 form submission serves to document
your time off request 2 please ensure that you have sought support from your reporting officer ro and
time off request form kt benefits pdf copy red ortax - Jul 08 2022

web time off request form kt benefits pdf pages 2 10 time off request form kt benefits pdf upload dona n boyle 2 10
downloaded from red ortax org on september 16 2023 by dona n boyle grant that films are motivated by profit and engage in
search for ways of improving profits but they do not consider them to be profit maximizing

time off request form kt benefits git 02 infra openwrt org - Apr 05 2022

web time off request form kt benefits food grade hydrogen peroxide benefits bing south korea wikipedia kt tape kt flex
reinforced adhesive strips for knees 8 etsi nfv what to say to an employee who s requesting too much time amazon summer
deals 100 exclusive amazon offers amp coupons thursday envelope st joseph school
[employee time off request form](#) - Sep 10 2022

web employee time off request form author eforms created date 20181024024647z
timeframe for ot payment hrsingapore - Aug 09 2022

web b overtime salary cycle from 15th of the previous month to 14th of the current month payable by 28th of the current
month c hence a is normal salary cycle calendar month while b is overtime salary cycle 15th to 14th but you pay both cycles
together in one payroll on the 28th we cut off at 15th

[request for time off fgps](#) - Jun 19 2023

web request for time off fgps please submit your request s at least three working days in advance if possible please ensure

your ro has been consulted and that you alert your ro and the relief planning team early once approval has been granted
thank you 1 name of requester 2 date 3

time off request form kt benefits pdf copy feed api stokecoll ac - Mar 04 2022

web time off request form kt benefits pdf is available in our book collection an online access to it is set as public so you can
get it instantly our digital library saves in multiple locations allowing you to get the most less latency time to
annual leave ministry of manpower - Feb 15 2023

web annual leave in accordance with the employment act you are entitled to paid annual leave if you have worked for your
employer for at least 3 months find out about your entitlements

request for one day time off form gov sg - Oct 23 2023

web request for one day time off 1 name of staff 2 form class 3 requested date for time off submit now

time off application form skss - Apr 17 2023

web to be submitted at least 3 working days in advance officers will receive approval non approval via email for urgent time
off requests less than 3 working days please submit this form and also text meet principal personally 1 officer s name as in
nric 2 officer s email address 3 time off date

hours of work overtime and rest day ministry of manpower - Mar 16 2023

web for overtime work your employer must pay you at least 1 5 times the hourly basic rate of pay payment must be made
within 14 days after the last day of the salary period a non workman earns 2 600 a month and works 2 hours of overtime the
overtime pay is 13 60 1 5 2 hours 40 80

time off application form gov sg - Jul 20 2023

web 1 please ensure approval is granted before taking your time off 2 inform the kps on duty for the arrangement of relief if
required

funko world of pop book set volume 1 volume 2 and volume - Nov 29 2022

web funko funko 2019 character toys 176 pages the eighth volume in the world of pop series offers collectors one of the
largest portfolios featuring their favorite pop culture

wopr worldpop - Feb 18 2022

web worldpop is an interdisciplinary applied research group focusing primarily on supporting improvement of the spatial
demographic evidence base and the use of these data for

k pop seduces youth in communist cuba birthplace of salsa - Aug 03 2020

web nov 1 2023 k pop supergroup blackpink rose to international fame after debuting in 2016 the group headlined
coachella this year and has collaborated with us singers such as

[word pop wordle battle](#) - Sep 15 2021

web 1 day ago play video 0 59 japan has gained another island after an undersea volcanic eruption 1 200 km south of tokyo created a new landmass the tiny island emerged

worldpop - Jul 26 2022

web bienvenue chez w o p mode créatifs la créativité est au coeur de notre adn la mode world of pop est colorée urbaine graphique et c est ce qui fait notre différence en

trailblazing computer scientist fei fei li on human centered ai - Dec 07 2020

web 14 hours ago in the middle of heaven knows is internet baby interlude led by a memorable hook and the repeated refrain of i am not your internet baby in the context

[pop the world of pop art hardcover 10 mar 2016](#) - Apr 22 2022

web w o p world of pop linkedin de 509 takipçi la marque de mode créative engagée pour toute la famille w o p world of pop est une marque de mode créative écoresponsable

open spatial demographic data and research worldpop - Mar 22 2022

web world of pop 808 likes 1 talking about this nossa sala no plug dj plug dj world of pop

pop culture rewind katy perry s left shark goes viral billboard - May 12 2021

web 19 hours ago skinnypop s lesserevil lesserevil popcorn 8 94 0 65 ounce buy now we earn a commission if you make a purchase at no additional cost to you

world of pop volume 8 by funko goodreads - Mar 02 2023

web through beautiful photography world of pop volume 8 provides an artistic look at a wide variety of figures released in 2018 to 2019 showcasing iconic characters from film

[funko shop exclusive item world of pop book bundle volumes](#) - Jul 06 2023

world population will therefore continue to grow in the 21st century but at a much slower rate compared to the recent past world population has doubled 100 increase in 40 years from 1959 3 billion to 1999 6 billion it see more

[amazon com world of warcraft funko pop](#) - Aug 27 2022

web world of pop is a book produced by funko detailing their releases within a particular year so far six volumes have been made

[world population clock 8 1 billion people live 2023](#) - Oct 09 2023

the chart above illustrates how world population has changed throughout history view the full tabulated data at the dawn of agriculture about 8000 b c the population of the world was approximately 5 million over the 8 000 year period up to 1 a d it grew to 200 million some estimate 300 million or see more

wordy pop play this game online for free now poki - Nov 17 2021

web nov 9 2023 dua lipa is one of the uk s biggest selling pop stars pop star dua lipa has given fans the first taste of her hotly anticipated third album with the release of a new

opinion jeff tweedy i thought i hated pop music dancing - Mar 10 2021

web nov 10 2023 more than 30 000 ordinary ukrainian men and women have trained to become soldiers under the largest military training programme of its kind on british soil

15 best vegan microwave popcorn and pre popped brands - Jun 12 2021

web 1 day ago k pop phenomenon eric nam walked away from a successful career after the industry took a heavy toll on his mental health nbc news savannah sellers sits down

w o p world of pop linkedin - Jun 24 2022

web funkopop world of warcraft illidan exclusive figure 4 4 out of 5 stars 38 23 80 23 80 free delivery nov 15 16 or fastest delivery wed nov 8 only 2 left in stock order

world of pop facebook - May 24 2022

web the worldpop program application programming interface api provides researcher and software developers access to worldpop data use this platform to spur innovation from

30 000 ukrainian recruits trained in largest uk military training - Apr 10 2021

web 13 hours ago billboard takes a look back at when the left shark from katy perry s 2015 super bowl performance went viral and turned into a huge internet meme evan burke

world of pop funkopop google books - Feb 01 2023

web world of pop volume 1 is the first edition of the world of pop books if you want to see where it all began world of pop book volume 1 is a must have in your funkopop

k pop blackpink s lisa face suspension on weibo cnn - Sep 03 2020

web 1 day ago nov 8 2023 4 47 pm pst by rebecca cohen members of shania twain s concert crew were hospitalized wednesday after a crash between tour stops in canada

blue lagoon in iceland temporarily closes after thousands of - Aug 15 2021

web word pop is a word guessing puzzle train your mind and challenge your friends on this amazing word puzzle game wordle battle train your mind and challenge your friends

eric nam on pressures of life as k pop star nbc news - Jul 14 2021

web by claire moose nov 9 2023 thousands of earthquakes recorded over the past few days have led to the pre-emptive closure of the blue lagoon an iconic tourist destination in

dua lipa returns with houdini does she still have the magic - Dec 19 2021

web world of pop 969 likes 10 talking about this la mode engagée des familles cools créative planète friendly unisex sustainable fashion

sag aftra and hollywood studios reach a tentative agreement - Nov 05 2020

web 5 hours ago ai is popping up everywhere nowadays from medicine to science to the hollywood strikes today with computer scientist and ai pioneer fei fei li we dig

world of pop funko pop wikia fandom - Oct 29 2022

web through beautiful photography world of pop volume 8 provides an artistic look at a wide variety of figures released in 2018 2019 showcasing iconic characters from film

new island emerges off japan after volcanic eruption video - Oct 17 2021

web wordy pop is a board game in which the player has to make as many words as possible create as many words as you can before the letters flood the screen and get the best

taylor swift s headed to argentina for her eras tour travis - May 31 2020

web 18 hours ago by chris rovzar november 9 2023 at 2 01 pm est save a temporary exhibition celebrating the history and innovation behind swiss watch brand omega

planet omega pop up in new york shows watches worn by - Jul 02 2020

web nov 7 2023 k pop the south korean sensation that has already swept over much of the rest of the world has made it to the shores of a communist isle that once banned the

w o p world of pop la mode engagée des familles cool - Sep 27 2022

web find many great new used options and get the best deals for funko world of pop book set volume 1 volume 2 and volume 3 hardcovers at the best online prices at ebay

former catalan politician shot in the face in madrid cnn - Feb 06 2021

web nov 2 2023 310 by jeff tweedy mr tweedy is the singer and guitarist of the band wilco and the author of world within a song music that changed my life and life that

shania twain s crew members hospitalized after tour bus crash - Oct 05 2020

web 1 day ago sag aftra the union representing more than 150 000 film and television performers reached a tentative deal on a new contract with the entertainment world s

music review on heaven knows internet pop sensation - Jan 08 2021

web 23 hours ago former popular party pp president in catalonia alejo vidal quadras was shot in the face in madrid on thursday afternoon a spokesman for spain s interior

world of pop volume 8 by funko hardcover barnes - Jun 05 2023

web vinyl personalized pops funko pop yourself free pet for limited time buy a custom pop figure get a companion for free now through 11 12 t cs apply lights strings

world of pop facebook - Jan 20 2022

web modelled population estimates for specific age sex groups for papua new guinea 2023 07 27 v1 0 details download png population report describing the statistical methods

funko official store home of pop vinyl personalized pops - Aug 07 2023

according to a recent study based on the 2010 world population of 6 9 billion by the pew forum there are see more

world of pop volume 8 amazon co uk - May 04 2023

web ashley anderson april 22 2019 happy world book day world of pop book bundle volumes 1 7 250 00 each limit of 1 item for a limited time receive free shipping

world of pop volume 8 funko 9781792313660 books - Dec 31 2022

web oct 1 2019 through beautiful photography world of pop volume 8 provides an artistic look at a wide variety of figures released in 2018 2019 showcasing iconic characters

world of pop funko 9781792313660 amazon com - Sep 08 2023

a tremendous change occurred with the industrial revolution whereas it had taken all of human history until around 1800 for world population to see more

world of pop volume 1 funko pop wikia fandom - Apr 03 2023

web oct 1 2019 through beautiful photography world of pop volume 8 provides an artistic look at a wide variety of figures released in 2018 2019 showcasing iconic characters