

HONDA
ENGINES

SHOP MANUAL

Includes Y Supplement

GX610 • GX620 ENGINE

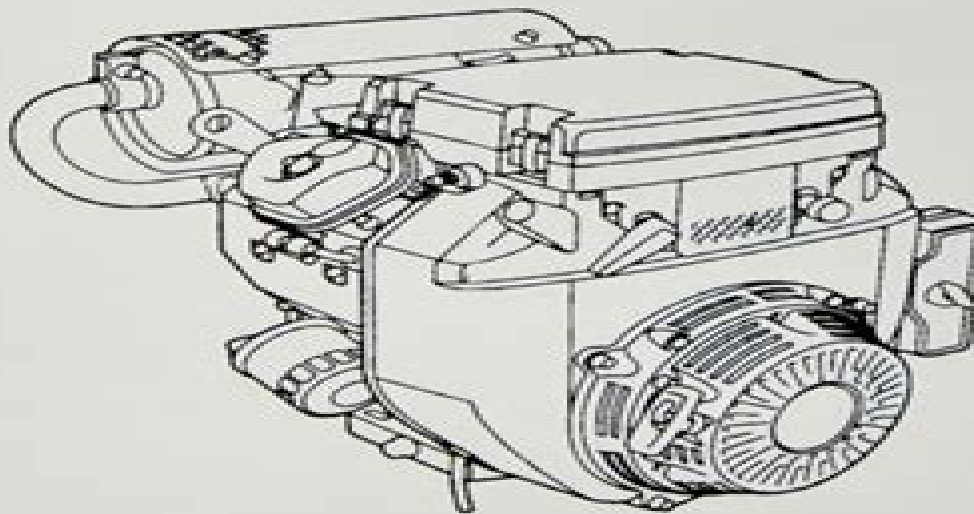

PSV61ZJ100E3.2015.05
THIRD EDITION

Honda Engine Repair Manual

Joacim Rocklöv



Honda Engine Repair Manual:

If you ally dependence such a referred **Honda Engine Repair Manual** ebook that will pay for you worth, acquire the unconditionally best seller from us currently from several preferred authors. If you want to witty books, lots of novels, tale, jokes, and more fictions collections are as a consequence launched, from best seller to one of the most current released.

You may not be perplexed to enjoy all ebook collections Honda Engine Repair Manual that we will certainly offer. It is not nearly the costs. Its approximately what you need currently. This Honda Engine Repair Manual, as one of the most working sellers here will categorically be among the best options to review.

<https://staging.conocer.cide.edu/files/virtual-library/fetch.php/Les%20Peintres%20Orientalistes%201850%201914%20Le%20Musee%20De%20Beauxarts%20Pau%20May%20June%201983.pdf>

Table of Contents Honda Engine Repair Manual

1. Understanding the eBook Honda Engine Repair Manual
 - The Rise of Digital Reading Honda Engine Repair Manual
 - Advantages of eBooks Over Traditional Books
2. Identifying Honda Engine Repair Manual
 - Exploring Different Genres
 - Considering Fiction vs. Non-Fiction
 - Determining Your Reading Goals
3. Choosing the Right eBook Platform
 - Popular eBook Platforms
 - Features to Look for in an Honda Engine Repair Manual
 - User-Friendly Interface
4. Exploring eBook Recommendations from Honda Engine Repair Manual
 - Personalized Recommendations
 - Honda Engine Repair Manual User Reviews and Ratings
 - Honda Engine Repair Manual and Bestseller Lists

5. Accessing Honda Engine Repair Manual Free and Paid eBooks
 - Honda Engine Repair Manual Public Domain eBooks
 - Honda Engine Repair Manual eBook Subscription Services
 - Honda Engine Repair Manual Budget-Friendly Options
6. Navigating Honda Engine Repair Manual eBook Formats
 - ePub, PDF, MOBI, and More
 - Honda Engine Repair Manual Compatibility with Devices
 - Honda Engine Repair Manual Enhanced eBook Features
7. Enhancing Your Reading Experience
 - Adjustable Fonts and Text Sizes of Honda Engine Repair Manual
 - Highlighting and Note-Taking Honda Engine Repair Manual
 - Interactive Elements Honda Engine Repair Manual
8. Staying Engaged with Honda Engine Repair Manual
 - Joining Online Reading Communities
 - Participating in Virtual Book Clubs
 - Following Authors and Publishers Honda Engine Repair Manual
9. Balancing eBooks and Physical Books Honda Engine Repair Manual
 - Benefits of a Digital Library
 - Creating a Diverse Reading Collection Honda Engine Repair Manual
10. Overcoming Reading Challenges
 - Dealing with Digital Eye Strain
 - Minimizing Distractions
 - Managing Screen Time
11. Cultivating a Reading Routine Honda Engine Repair Manual
 - Setting Reading Goals Honda Engine Repair Manual
 - Carving Out Dedicated Reading Time
12. Sourcing Reliable Information of Honda Engine Repair Manual
 - Fact-Checking eBook Content of Honda Engine Repair Manual
 - Distinguishing Credible Sources
13. Promoting Lifelong Learning

- Utilizing eBooks for Skill Development
 - Exploring Educational eBooks
14. Embracing eBook Trends
- Integration of Multimedia Elements
 - Interactive and Gamified eBooks

Honda Engine Repair Manual Introduction

In this digital age, the convenience of accessing information at our fingertips has become a necessity. Whether its research papers, eBooks, or user manuals, PDF files have become the preferred format for sharing and reading documents. However, the cost associated with purchasing PDF files can sometimes be a barrier for many individuals and organizations. Thankfully, there are numerous websites and platforms that allow users to download free PDF files legally. In this article, we will explore some of the best platforms to download free PDFs. One of the most popular platforms to download free PDF files is Project Gutenberg. This online library offers over 60,000 free eBooks that are in the public domain. From classic literature to historical documents, Project Gutenberg provides a wide range of PDF files that can be downloaded and enjoyed on various devices. The website is user-friendly and allows users to search for specific titles or browse through different categories. Another reliable platform for downloading Honda Engine Repair Manual free PDF files is Open Library. With its vast collection of over 1 million eBooks, Open Library has something for every reader. The website offers a seamless experience by providing options to borrow or download PDF files. Users simply need to create a free account to access this treasure trove of knowledge. Open Library also allows users to contribute by uploading and sharing their own PDF files, making it a collaborative platform for book enthusiasts. For those interested in academic resources, there are websites dedicated to providing free PDFs of research papers and scientific articles. One such website is Academia.edu, which allows researchers and scholars to share their work with a global audience. Users can download PDF files of research papers, theses, and dissertations covering a wide range of subjects. Academia.edu also provides a platform for discussions and networking within the academic community. When it comes to downloading Honda Engine Repair Manual free PDF files of magazines, brochures, and catalogs, Issuu is a popular choice. This digital publishing platform hosts a vast collection of publications from around the world. Users can search for specific titles or explore various categories and genres. Issuu offers a seamless reading experience with its user-friendly interface and allows users to download PDF files for offline reading. Apart from dedicated platforms, search engines also play a crucial role in finding free PDF files. Google, for instance, has an advanced search feature that allows users to filter results by file type. By specifying the file type as "PDF," users can find websites that offer free PDF downloads on a specific topic. While downloading Honda Engine Repair Manual free PDF files is convenient,

its important to note that copyright laws must be respected. Always ensure that the PDF files you download are legally available for free. Many authors and publishers voluntarily provide free PDF versions of their work, but its essential to be cautious and verify the authenticity of the source before downloading Honda Engine Repair Manual. In conclusion, the internet offers numerous platforms and websites that allow users to download free PDF files legally. Whether its classic literature, research papers, or magazines, there is something for everyone. The platforms mentioned in this article, such as Project Gutenberg, Open Library, Academia.edu, and Issuu, provide access to a vast collection of PDF files. However, users should always be cautious and verify the legality of the source before downloading Honda Engine Repair Manual any PDF files. With these platforms, the world of PDF downloads is just a click away.

FAQs About Honda Engine Repair Manual Books

What is a Honda Engine Repair Manual PDF? A PDF (Portable Document Format) is a file format developed by Adobe that preserves the layout and formatting of a document, regardless of the software, hardware, or operating system used to view or print it. **How do I create a Honda Engine Repair Manual PDF?** There are several ways to create a PDF: Use software like Adobe Acrobat, Microsoft Word, or Google Docs, which often have built-in PDF creation tools. Print to PDF: Many applications and operating systems have a "Print to PDF" option that allows you to save a document as a PDF file instead of printing it on paper. Online converters: There are various online tools that can convert different file types to PDF. **How do I edit a Honda Engine Repair Manual PDF?** Editing a PDF can be done with software like Adobe Acrobat, which allows direct editing of text, images, and other elements within the PDF. Some free tools, like PDFescape or Smallpdf, also offer basic editing capabilities. **How do I convert a Honda Engine Repair Manual PDF to another file format?** There are multiple ways to convert a PDF to another format: Use online converters like Smallpdf, Zamzar, or Adobe Acrobats export feature to convert PDFs to formats like Word, Excel, JPEG, etc. Software like Adobe Acrobat, Microsoft Word, or other PDF editors may have options to export or save PDFs in different formats. **How do I password-protect a Honda Engine Repair Manual PDF?** Most PDF editing software allows you to add password protection. In Adobe Acrobat, for instance, you can go to "File" -> "Properties" -> "Security" to set a password to restrict access or editing capabilities. Are there any free alternatives to Adobe Acrobat for working with PDFs? Yes, there are many free alternatives for working with PDFs, such as: LibreOffice: Offers PDF editing features. PDFsam: Allows splitting, merging, and editing PDFs. Foxit Reader: Provides basic PDF viewing and editing capabilities. How do I compress a PDF file? You can use online tools like Smallpdf, ILovePDF, or desktop software like Adobe Acrobat to compress PDF files without significant quality loss. Compression reduces the file size, making it easier to share and download. Can I fill out forms in a PDF file? Yes, most PDF viewers/editors like Adobe Acrobat,

Preview (on Mac), or various online tools allow you to fill out forms in PDF files by selecting text fields and entering information. Are there any restrictions when working with PDFs? Some PDFs might have restrictions set by their creator, such as password protection, editing restrictions, or print restrictions. Breaking these restrictions might require specific software or tools, which may or may not be legal depending on the circumstances and local laws.

Find Honda Engine Repair Manual :

les peintres orientalistes 1850 1914 le musee de beauxarts pau may june 1983

leonardito y la bicicleta

les clochards celestes

leon y la zorra

les 4 as et le diamant blue

lerna volume 3 the pottery of lerna iv

les dollars de la terreur

les r cits habidiqes tome 2

les jours modernes a fils tires

leopard in exile

les derniers jours de hong kong

leonor fini et son oeuvre

les halles lalbum du coeur de paris

les enfants de gogol

leo strauss political philosopher and jewish thinker

Honda Engine Repair Manual :

drawing chemical engineering ia drc1501 unisa ac za - Jun 18 2022

web purpose the purpose of this module is to introduce students to drawing techniques and dimensioning students completing this module will gain basic skills required for engineering communication with the aid of drawings they will learn the basics of sketching dimensioning pictorial and orthographic drawing

national diploma engineering chemical ndeng university - Feb 12 2022

web national diploma engineering chemical who can register applicants new applicants unisa students who applied for

admission to a new qualification may only register if they have received an offer of placement from unisa and have accepted the offer online

[online utsa edu](#) - Jul 20 2022

web 301 moved permanently nginx

drawing chemical engineering ia drc1501 w2 unisa ac za - Mar 16 2022

web register to study through unisa undergraduate honours qualifications master s doctoral degrees subjects modules short learning programmes student policies rules pay your study fees credits exemptions for study units passed at other institutions map your qualification web registration payment methods and banking details

chemical engineering university of south africa - Jun 30 2023

web purpose drawing equipment sa standard code of drawing sabs lettering letters numerals symbols sketching or free hand drawing practical geometry basic loci and simple mechanisms conic sections orthographic projection isometric and oblique projection auxiliary views lines of interpenetration surface development sketches

diploma in chemical engineering at unisa unisasapplication - Nov 23 2022

web diploma in chemical engineering is a three year diploma level engineering programme that equips the learners with the knowledge of creating something useful and new using chemicals or raw materials along with life sciences and physical sciences maximum time to complete this qualification 8 years admission requirements

drc1501 101 1 2020 pdf drc1501 101 1 2020 tutorial letter - May 30 2023

web 1 introduction to the module welcome to the module chemical engineering drawing code drc1501 offered by the chemical engineering section in the school of engineering at unisa this module is delivered fully and only online

drawing chemical engineering unisa online pdf 2023 - Sep 21 2022

web drawing chemical engineering unisa online pdf pages 2 16 drawing chemical engineering unisa online pdf upload jason h paterson 2 16 downloaded from digitalworkgroup skidmore edu on september 25 2023 by jason h paterson smooth transition from school to work

[engineering drawing and computer aided design study at unisa](#) - Mar 28 2023

web fee paying program for domestic and international students international students and students undertaking this course as part of a postgraduate fee paying program must refer to the relevant program home page to determine the cost for undertaking this course non award enrolment non award tuition fees are set by the university

rscb pdb chemical sketch tool - Dec 25 2022

web chemical sketch tool use the chemical sketch tool to draw or edit a molecule the resulting smiles or inchi string may be used to search for matching molecules in the pdb chemical component dictionary note that matches will include any chemical

component in the dictionary including polymeric ones like alanine or adenosine

drc1501 101 1 2020 drawing chemical engineering i - Sep 02 2023

web apr 22 2020 studying fully online modules differs completely from studying other modules at unisa all your study material and learning activities for online modules are designed to be delivered online via myunisa all your assignments must be submitted online this means that you will complete all your activities and submit all your assignments via

drawing chemical engineering i dce1501 unisa ac za - Oct 03 2023

web drawing chemical engineering i dce1501 purpose drawing equipment sa standard code of drawing sabs lettering letters numerals symbols sketching or free hand drawing practical geometry basic loci and simple mechanisms conic sections orthographic projection isometric and oblique projection auxiliary views lines of

department of chemical engineering unisa ac za - May 18 2022

web read more chemical engineering is concerned with the industrial processes involved in the physical or chemical conversion of raw materials into products with a higher economic and or social value chemical engineers also play a key role in the conservation and protection of the environment

diploma in chemical engineering 90130 university of south - Feb 24 2023

web diploma in chemical engineering who can register applicants new applicants unisa students who applied for admission to a new qualification may only register if they have received an offer of placement from unisa and have accepted the offer online

department of chemical engineering university of south africa - Jan 26 2023

web aug 7 2023 chemical engineering is concerned with the industrial processes involved in the physical or chemical conversion of raw materials into products with a higher economic and or social value chemical engineers also play a key role in the conservation and protection of the environment chemical engineers enjoy a wide variety of employment

national diploma engineering chemical rikvip online - Aug 21 2022

web unisa s centre for life long learning thabo mbeki african school of public press international affairs general information advancing excellence through our colleges open lectures 2023 2022 2021 research research research vice principal s request problem solving research the relevance and impact people in research people in research

drawing chemical engineering unisa online - Oct 23 2022

web drawing chemical engineering unisa online sitemap sa studysa study june 24th 2018 we are not an institution so please contact the relevant institution directly for course information transnet youth recruitment south africa june 24th 2018 comment made by ntokoza sandile zondo on apr 13th 2017 at 11 29 am

diploma in chemical engineering 90130 university of south - Apr 16 2022

web undergraduate qualifications diploma in chemical engineering closing date for applications to undergraduate qualifications for the 2024 academic year extended to 17 november 2023 college of accounting sciences and the college of science engineering and technology open until 31 january 2024 maximum time to complete this

[national diploma engineering chemical ndeng university](#) - Apr 28 2023

web national diploma engineering chemical who can register applicants new applicants unisa students who applied for admission to a new qualification may only register if they have received an offer of placement from unisa and have accepted the offer online

[drc1501 101 1 2020 drawing chemical engineering i pdf](#) - Aug 01 2023

web 1 introduction to the module welcome to the module chemical engineering drawing code drc1501 offered by the chemical engineering section in the school of engineering at unisa this module is delivered fully and only online

[truck driver cover letter examples samples for 2023 jobhero](#) - Jul 16 2023

web view all cover letter examples for help with your resume check out our extensive truck driver resumes improve your chances of getting noticed with a powerful cover letter take a look at our guide to create the best cover letter in 2023

[truck driver cover letter samples and templates resumecat](#) - Feb 28 2022

web aug 11 2022 truck driver cover letter examples a great truck driver cover letter can help you stand out from the competition when applying for a job be sure to tailor your letter to the specific requirements listed in the job description and highlight your most relevant or exceptional qualifications

[free truck driver cover letter templates resume now](#) - Oct 07 2022

web the cover letter is vital for letting the employer know that you can meet their needs and you should use this critical document to grab the hiring manager s attention our free truck driver cover letter templates are a great place to start and samples are available below

[truck driver cover letter examples driving livecareer](#) - Mar 12 2023

web to get started click on any of the cover letter examples below these cover letter examples show what should go into a truck driver cover letter and you can use them as fuel in creating your own cover letter build your cover letter today and get the job soon

[how to write a truck driver cover letter with an example](#) - May 14 2023

web aug 11 2023 indeed editorial team updated august 11 2023 a cover letter is an excellent opportunity to tell a hiring manager about who you are and demonstrate what makes you a good fit for the role it s also a chance to give them more details about your successes personal qualities and to show your motivation

[truck driver cover letter example kickresume](#) - Sep 06 2022

web i am writing this letter to express my deep interest in applying for the truck driver job within prp transport inc as advertised on indeed com as i am confident that the combination of my previous experience and multiple developed skills and qualities makes me a perfect candidate for the role

driver logistics driver cover letter samples examples 2023 - Apr 01 2022

web dec 14 2022 here s an example of an effective driver cover letter closing statement i am beyond grateful for your time and consideration and hope to hear from you shortly regarding this position the best way to reach me on weekdays is at 123 456 7890 between the hours of 7 a m to 4 p m or at janedoe email com on weekends

truck driver cover letter example and template for 2023 - Oct 19 2023

web may 2 2023 in this article we explain what to include in a truck driver cover letter and share an example of a cover letter to help you write your own if you re interested in pursuing this career you might create several documents for job applications including cover letters reference sheets and a resume that lists your employment history

truck driver cover letter examples and templates for 2023 - Aug 17 2023

web apr 20 2023 our downloadable cover letter examples can help you write a cover letter that has a big impact there are templates to help experienced and entry level truck drivers plus extra tips to help you strengthen your cover letter s most important sections

truck driver sample cover letter ziprecruiter - Aug 05 2022

web oct 30 2023 crafting a clear and concise cover letter is not always easy review the sample below adjust it to your writing style then personalize it with the best examples from your own work experience this free cover letter for truck driver jobs was created in part with the openai api and thoroughly edited and fact checked by our editorial team

truck driver cover letter example great sample resume - Jul 04 2022

web here is the reliable truck driver cover letter example dear mr streetman on indeed com i saw your posting for a truck driver i was pleased since i m looking for such a position part time and have the experience required

2023 truck driver cover letter examples buildfreeresume com - Jun 03 2022

web jul 23 2023 introduction 1 truck driver cover letter example experienced 2 truck driver cover letter example entry level conclusion introduction truck driver cover letter examples will help you write better cover letters welcome to our comprehensive guide on creating compelling truck driver cover letters

real truck driver cover letter example for 2023 enhancv - Nov 08 2022

web professional truck driver cover letter example for 2023 read for inspiration or use it as a base to improve your own truck driver cover letter just replace personal information company application data and achievements with your own create a cover letter read the guide david r fay truck driver 1 555 0100 name gmail com

[truck driver cover letter sample monster com](#) - Dec 09 2022

web feb 5 2018 to be considered for top truck driver jobs your cover letter must demonstrate your skills and experience as well as your passion for your work for writing tips view this sample cover letter for a truck driver or download the truck driver cover letter template in word

[how to write a truck driver cover letter in 8 steps indeed](#) - Jan 10 2023

web jun 14 2023 1 start with a header include a header in the top left corner of your page this header typically includes your first and last name phone number email address and location these details tell hiring managers how to contact you if

truck driver cover letter betterteam - Feb 11 2023

web full name physical address telephone number email address date application for the position of truck driver dear recipient s title and last name i am writing to apply for the position of truck driver as advertised on in where you saw the advertisement

[truck driver cover letter examples expert tips free](#) - Jun 15 2023

web truck driver cover letter example an outstanding truck driver cover letter can be your ignition key to the job move that s right for you follow resume io s step by step writing tips and sample sentences designed specifically for truck drivers in 2022 you ll be well on your way to trucking career success with no wrong turns 4 2 average rating

truck driver cover letter example writing tips resume - Sep 18 2023

web mar 6 2023 truck driver cover letter example show off your truck driving experience while you should already include your driving experience in your truck driver tailor your truck driver skills and qualifications if you re an experienced driver be detailed when listing your hard emphasize your

truck driver cover letter with examples zippia - May 02 2022

web determination often truck drivers have to drive for long periods into the wee hours of the night traveling routes under these circumstances requires a considerable amount of effort and determination as a lack of motivation might

truck driver cover letter example myperfectresume - Apr 13 2023

web the average hourly wage for a truck driver is just over 18 dollars an hour the demand for heavy and tractor trailer drivers is expected to increase approximately 11 percent through 2022 a truck driver cover letter should include realistic salary expectations

memory and nostalgia in cinema pam cook taylor - Feb 05 2023

web oct 27 2004 pam cook also investigates the recent history of film studies reviewing the developments that have culminated in the exciting if daunting present moment the result is a rich and stimulating volume that will appeal to anyone with an interest in cinema memory and identity

books kinokuniya the cinema book 3rd cook pam edt - Oct 01 2022

web the cinema book is widely recognised as the ultimate guide to cinema authoritative and comprehensive the third edition has been extensively revised updated and expanded in response to developments in cinema and cinema studies lavishly illustrated in colour this edition features a wealth

the cinema book by pam cook goodreads - Sep 12 2023

web jan 1 2001 pam cook editor contributor mieke bernink editor 4 22 183 ratings 3 reviews the cinema book is widely recognized as the ultimate guide to cinema authoritative and comprehensive the third edition has been extensively revised updated and expanded in response to developments in cinema and cinema studies

the cinema book pam cook google books - Jan 04 2023

web the cinema book is widely recognised as the ultimate guide to cinema authoritative and comprehensive the third edition has been extensively revised updated and expanded in response to

the cinema book cook pam cook pam bernink mieke - May 28 2022

web covering contemporary film studies this edition comprises seven sections history of cinema cinema technology movements in cinema alternatives to hollywood genre auteurs and theoretical frameworks other topics included are cinema technology and feminist film theory

the cinema book wikipedia - May 08 2023

web the cinema book is a film studies textbook edited by pam cook and first published by the british film institute bfi in 1985 as a resource for teachers the first edition was based on the bfi education department s collection of film clips for use as study guides

golden village new movies in singapore gv - Feb 22 2022

web coming soon free tickets cannot be used for movie admission view all movies free tickets cannot be used for movie admission what s on golden village is the leading movie theatre in singapore offering the widest variety of new and upcoming movie releases with varied cinematic experiences

pam cook ed the cinema book 3rd edn london palgrave - Jul 30 2022

web for this edition cook provides a summary of auteur theory in britain which is focused largely on the cinephiles of movie in the 1960s and their championing of directors such as joseph losey and elia kazan

the cinema book free download borrow and streaming - Aug 11 2023

web access restricted item true addeddate 2019 10 23 00 51 15 associated names cook pam bernink mieke boxid ia1678822 camera

the cinema book cook pam 9781844571932 amazon com - Aug 31 2022

web dec 31 2007 it provides comprehensive coverage of seven major areas hollywood cinema and beyond the star system technologies world cinemas genre authorship and cinema and developments in theory new topics include global hollywood contemporary women directors african american cinema queer theory and

the cinema book by pam cook amazon co uk - Oct 13 2023

web 4 7 65 ratings see all formats and editions the cinema book is widely recognised as the ultimate guide to cinema authoritative and comprehensive the third edition has been extensively revised updated and expanded in response to developments in cinema and cinema studies

the cinema book 3rd edition eprints soton - Mar 06 2023

web cook pam ed 2007 the cinema book 3rd edition london gb british film institute 610pp

the cinema book google books - Jul 10 2023

web nov 5 2007 the cinema book pam cook british film institute nov 5 2007 performing arts 610 pages first published in 1985 thecinema bookwas hailed as a landmark film studies text presenting in

the cinema book cook pam bernink mieke cook pam - Jun 09 2023

web covering contemporary film studies this edition comprises seven sections history of cinema cinema technology movements in cinema alternatives to hollywood genre auteurs and theoretical frameworks other topics included are cinema technology and feminist film theory

amazon com the cinema book 9780851707266 bernink meike cook pam - Apr 26 2022

web dec 1 1999 pam cook edited the 1985 edition of the cinema book and is currently professor of european film and media at the university of southampton her most recent book is gainsborough pictures 1924 1950 1997

screening the past memory and nostalgia in cinema google - Jun 28 2022

web pam cook is professor of european film and media at the university of southampton she is co editor of the cinema book bfi 1999 and her many publications on film include fashioning the

screening the past memory and nostalgia in cinema routledge - Nov 02 2022

web by routledge description from mildred pierce and brief encounter to raging bull and in the mood for love this lively and accessible collection explores film culture s obsession with the past offering searching and provocative analyses of a wide range of titles

golden village cinemas movie theatres gv - Mar 26 2022

web movie theatres golden village multiplex pte ltd a wholly owned subsidiary of orange sky golden harvest entertainment holdings is singapore s leading cinema exhibitor with 15 multiplexes and 119 screens gv is the first local cinema company to personalise the movie going experience through its movie club program which has a reach of

the cinema book google books - Apr 07 2023

web pam cook british film institute 2007 motion pictures 624 pages the cinema book is widely recognised as the ultimate guide to cinema authoritative and comprehensive the third edition

the cinema book 3rd edition by pam cook open library - Dec 03 2022

web dec 3 2007 created by an anonymous user imported from amazon com record the cinema book by pam cook december 3 2007 british film institute edition paperback in english 3 edition