

HONDA

GX120 · GX160 · GX200

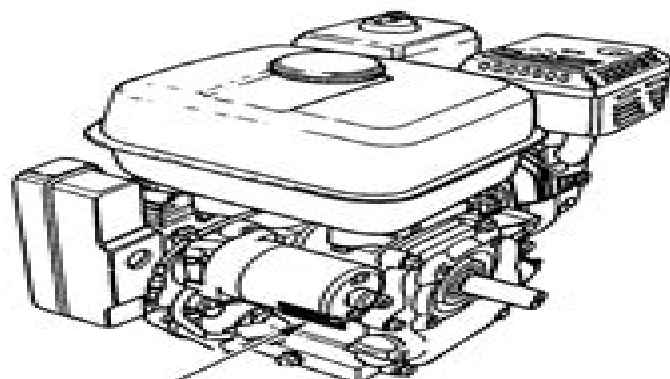

Serial number and
engine type

OWNER'S MANUAL

32ZH7620
00X32-ZH7-6201

1

HONDA EUROPE N.V. (EEC)
www.honda-engines-eu.com



Honda Gx160 Engine Repair Manual

C Cleary



Honda Gx160 Engine Repair Manual:

Embark on a breathtaking journey through nature and adventure with Explore with is mesmerizing ebook, Natureis Adventure: **Honda Gx160 Engine Repair Manual** . This immersive experience, available for download in a PDF format (Download in PDF: *), transports you to the heart of natural marvels and thrilling escapades. Download now and let the adventure begin!

https://staging.conocer.cide.edu/About/book-search/default.aspx/langenscheidts_standard_german_dictionary.pdf

Table of Contents Honda Gx160 Engine Repair Manual

1. Understanding the eBook Honda Gx160 Engine Repair Manual
 - The Rise of Digital Reading Honda Gx160 Engine Repair Manual
 - Advantages of eBooks Over Traditional Books
2. Identifying Honda Gx160 Engine Repair Manual
 - Exploring Different Genres
 - Considering Fiction vs. Non-Fiction
 - Determining Your Reading Goals
3. Choosing the Right eBook Platform
 - Popular eBook Platforms
 - Features to Look for in an Honda Gx160 Engine Repair Manual
 - User-Friendly Interface
4. Exploring eBook Recommendations from Honda Gx160 Engine Repair Manual
 - Personalized Recommendations
 - Honda Gx160 Engine Repair Manual User Reviews and Ratings
 - Honda Gx160 Engine Repair Manual and Bestseller Lists
5. Accessing Honda Gx160 Engine Repair Manual Free and Paid eBooks
 - Honda Gx160 Engine Repair Manual Public Domain eBooks
 - Honda Gx160 Engine Repair Manual eBook Subscription Services
 - Honda Gx160 Engine Repair Manual Budget-Friendly Options

6. Navigating Honda Gx160 Engine Repair Manual eBook Formats
 - ePub, PDF, MOBI, and More
 - Honda Gx160 Engine Repair Manual Compatibility with Devices
 - Honda Gx160 Engine Repair Manual Enhanced eBook Features
7. Enhancing Your Reading Experience
 - Adjustable Fonts and Text Sizes of Honda Gx160 Engine Repair Manual
 - Highlighting and Note-Taking Honda Gx160 Engine Repair Manual
 - Interactive Elements Honda Gx160 Engine Repair Manual
8. Staying Engaged with Honda Gx160 Engine Repair Manual
 - Joining Online Reading Communities
 - Participating in Virtual Book Clubs
 - Following Authors and Publishers Honda Gx160 Engine Repair Manual
9. Balancing eBooks and Physical Books Honda Gx160 Engine Repair Manual
 - Benefits of a Digital Library
 - Creating a Diverse Reading Collection Honda Gx160 Engine Repair Manual
10. Overcoming Reading Challenges
 - Dealing with Digital Eye Strain
 - Minimizing Distractions
 - Managing Screen Time
11. Cultivating a Reading Routine Honda Gx160 Engine Repair Manual
 - Setting Reading Goals Honda Gx160 Engine Repair Manual
 - Carving Out Dedicated Reading Time
12. Sourcing Reliable Information of Honda Gx160 Engine Repair Manual
 - Fact-Checking eBook Content of Honda Gx160 Engine Repair Manual
 - Distinguishing Credible Sources
13. Promoting Lifelong Learning
 - Utilizing eBooks for Skill Development
 - Exploring Educational eBooks
14. Embracing eBook Trends
 - Integration of Multimedia Elements

- Interactive and Gamified eBooks

Honda Gx160 Engine Repair Manual Introduction

Free PDF Books and Manuals for Download: Unlocking Knowledge at Your Fingertips In today's fast-paced digital age, obtaining valuable knowledge has become easier than ever. Thanks to the internet, a vast array of books and manuals are now available for free download in PDF format. Whether you are a student, professional, or simply an avid reader, this treasure trove of downloadable resources offers a wealth of information, conveniently accessible anytime, anywhere. The advent of online libraries and platforms dedicated to sharing knowledge has revolutionized the way we consume information. No longer confined to physical libraries or bookstores, readers can now access an extensive collection of digital books and manuals with just a few clicks. These resources, available in PDF, Microsoft Word, and PowerPoint formats, cater to a wide range of interests, including literature, technology, science, history, and much more. One notable platform where you can explore and download free Honda Gx160 Engine Repair Manual PDF books and manuals is the internet's largest free library. Hosted online, this catalog compiles a vast assortment of documents, making it a veritable goldmine of knowledge. With its easy-to-use website interface and customizable PDF generator, this platform offers a user-friendly experience, allowing individuals to effortlessly navigate and access the information they seek. The availability of free PDF books and manuals on this platform demonstrates its commitment to democratizing education and empowering individuals with the tools needed to succeed in their chosen fields. It allows anyone, regardless of their background or financial limitations, to expand their horizons and gain insights from experts in various disciplines. One of the most significant advantages of downloading PDF books and manuals lies in their portability. Unlike physical copies, digital books can be stored and carried on a single device, such as a tablet or smartphone, saving valuable space and weight. This convenience makes it possible for readers to have their entire library at their fingertips, whether they are commuting, traveling, or simply enjoying a lazy afternoon at home. Additionally, digital files are easily searchable, enabling readers to locate specific information within seconds. With a few keystrokes, users can search for keywords, topics, or phrases, making research and finding relevant information a breeze. This efficiency saves time and effort, streamlining the learning process and allowing individuals to focus on extracting the information they need. Furthermore, the availability of free PDF books and manuals fosters a culture of continuous learning. By removing financial barriers, more people can access educational resources and pursue lifelong learning, contributing to personal growth and professional development. This democratization of knowledge promotes intellectual curiosity and empowers individuals to become lifelong learners, promoting progress and innovation in various fields. It is worth noting that while accessing free Honda Gx160 Engine Repair Manual PDF books and manuals is convenient and cost-effective, it is vital to respect copyright laws and intellectual property rights. Platforms offering free downloads often operate within legal

boundaries, ensuring that the materials they provide are either in the public domain or authorized for distribution. By adhering to copyright laws, users can enjoy the benefits of free access to knowledge while supporting the authors and publishers who make these resources available. In conclusion, the availability of Honda Gx160 Engine Repair Manual free PDF books and manuals for download has revolutionized the way we access and consume knowledge. With just a few clicks, individuals can explore a vast collection of resources across different disciplines, all free of charge. This accessibility empowers individuals to become lifelong learners, contributing to personal growth, professional development, and the advancement of society as a whole. So why not unlock a world of knowledge today? Start exploring the vast sea of free PDF books and manuals waiting to be discovered right at your fingertips.

FAQs About Honda Gx160 Engine Repair Manual Books

What is a Honda Gx160 Engine Repair Manual PDF? A PDF (Portable Document Format) is a file format developed by Adobe that preserves the layout and formatting of a document, regardless of the software, hardware, or operating system used to view or print it. **How do I create a Honda Gx160 Engine Repair Manual PDF?** There are several ways to create a PDF: Use software like Adobe Acrobat, Microsoft Word, or Google Docs, which often have built-in PDF creation tools. Print to PDF: Many applications and operating systems have a "Print to PDF" option that allows you to save a document as a PDF file instead of printing it on paper. Online converters: There are various online tools that can convert different file types to PDF. **How do I edit a Honda Gx160 Engine Repair Manual PDF?** Editing a PDF can be done with software like Adobe Acrobat, which allows direct editing of text, images, and other elements within the PDF. Some free tools, like PDFescape or Smallpdf, also offer basic editing capabilities. **How do I convert a Honda Gx160 Engine Repair Manual PDF to another file format?** There are multiple ways to convert a PDF to another format: Use online converters like Smallpdf, Zamzar, or Adobe Acrobats export feature to convert PDFs to formats like Word, Excel, JPEG, etc. Software like Adobe Acrobat, Microsoft Word, or other PDF editors may have options to export or save PDFs in different formats. **How do I password-protect a Honda Gx160 Engine Repair Manual PDF?** Most PDF editing software allows you to add password protection. In Adobe Acrobat, for instance, you can go to "File" -> "Properties" -> "Security" to set a password to restrict access or editing capabilities. Are there any free alternatives to Adobe Acrobat for working with PDFs? Yes, there are many free alternatives for working with PDFs, such as: LibreOffice: Offers PDF editing features. PDFsam: Allows splitting, merging, and editing PDFs. Foxit Reader: Provides basic PDF viewing and editing capabilities. How do I compress a PDF file? You can use online tools like Smallpdf, ILovePDF, or desktop software like Adobe Acrobat to compress PDF files without significant quality loss. Compression reduces the file size, making it easier to share and download. Can I fill out forms in a PDF file? Yes, most PDF

viewers/editors like Adobe Acrobat, Preview (on Mac), or various online tools allow you to fill out forms in PDF files by selecting text fields and entering information. Are there any restrictions when working with PDFs? Some PDFs might have restrictions set by their creator, such as password protection, editing restrictions, or print restrictions. Breaking these restrictions might require specific software or tools, which may or may not be legal depending on the circumstances and local laws.

Find Honda Gx160 Engine Repair Manual :

~~langenscheidts standard german dictionary~~

languages of class studies in english working class history 1832-1982

language inventory for teachers

language30 greek with

land use control geography law and public policy

language and thought

land-based marine pollution international law development

landlords and capitalists

language and control in childrens literature

language arts today by mccallum

language decline and death in africa causes consequences and challenges

language education and discourse functional approaches

landscape in perspective drawings by rembrandt and his contemporaries

langue et langue

language of nuclear war an intelligent citizens dictionary

Honda Gx160 Engine Repair Manual :

la cabaña del terror de los simpson la - Jun 12 2023

web el cómic la cabaña del terror de los simpson la broma del muerto en casa del libro descubre las mejores ofertas y envíos gratis

la broma del muerto la cabana del terror de los s 2022 ftp - Feb 25 2022

web apr 23 2023 la broma del muerto la cabana del terror de los s 2 11 downloaded from uniport edu ng on april 23 2023

by guest o cunqueiro en cada página un huésped

la broma del muerto la cabaña del terror de los simpson 2 - Jul 13 2023

web la broma del muerto la cabaña del terror de los simpson 2 groening matt amazon es libros

küba da otelde korkunç patlama 22 ölü ahaber son dakika - Nov 24 2021

web el muerto film konusu Örumcek adam evrenin n yan karakterlerinden olan el muerto Örumcek adam in ölümden kurtardığı süper güçlü bir güreşçi babası el dorado olarak

la cabaña del terror de los simpson la broma - Mar 09 2023

web libro la cabaña del terror de los simpson la broma del muerto del autor matt groening al mejor precio nuevo o segunda mano en casa del libro

la cabaña del terror de los simpson la broma del - Nov 05 2022

web una història apassionant de la humanitat a través de les idees científiques tecnològiques i socials que ens han permès assolir nivells de prosperitat colossals un homenatge a les

la mejor bromas del 2022 el muerto en la camilla youtube - Dec 26 2021

web may 7 2022 küba nın başkenti havana da bir otelde şiddetli patlama meydana geldi bir kısmı yıkılan tarihi binadan alevler yükseldi 22 kişi hayatını kaybetti benzer bir patlama

la cabaña del terror de los simpson la broma - Sep 03 2022

web that s the least of his troubles lately mythological monsters and the gods of mount olympus seem to be walking straight out of the pages of percy s greek mythology

la broma del muerto la cabana del terror de los s john boyne - Aug 02 2022

web la famosa tragicomedia de la entrada del marques de los velez en cataluña y assalto de monjuque in three acts and in verse sep 03 2022 antología sanmartiniana sep 22

la broma del muerto la cabana del terror de los s - Jan 27 2022

web shorts viral fyp

la broma del muerto la cabaña del terror de los simpson 2 - Feb 08 2023

web la broma del muerto la cabaña del terror de los simpson 2 libro de editorial bruguera libros con 5 de descuento y envío gratis desde 19

la cabaña del terror de los simpson la broma del muerto - Aug 14 2023

web la cabaña del terror de los simpson la broma del muerto book read reviews from world s largest community for readers rare book

la cabaña del terror de los simpson la broma - Oct 04 2022

web sinopsis de la cabaña del terror de los simpson la broma del muerto no hace mucho tiempo que halloween era una fiesta casi desconocida en nuestro país

la cabaña del terror de los simpson la broma del muerto - Dec 06 2022

web la cabaña del terror de los simpson la broma del muerto no hace mucho tiempo que halloween era una fiesta casi desconocida en nuestro país y para muchos tiene algo

la broma del muerto la cabaña del terror de los simpson 2 - May 11 2023

web oct 13 2016 amazon com la broma del muerto la cabaña del terror de los simpson 2 9788466659505 groening matt books

la broma del muerto la cabana del terror de los s 2023 - Jul 01 2022

web Ölüm fırtınası filmi oyuncularını nadia farès john brumpton david lyons mathew wilkinson jonathan oldham yapımcı gary hamilton pete ford ann darrouzet

el muerto 2024 filmi sinemalar com - Oct 24 2021

la broma del muerto la cabaña del terror de los simpson 2 - Jan 07 2023

web matt groening el maestro del caos alegre se una monstruos la broma del muerto la cabaña del terror de los simpson 2 librotea escoged vuestra propia tumba entre

la broma del muerto la cabana del terror de los s bruce d - Apr 10 2023

web dazzling freewheeling account of oliveira s astonishing adventures emma jane austen world literature classics illustrated with doodles jane austen 2021 02 17 one of the

la broma del muerto la cabana del terror de los s copy - Apr 29 2022

web Özet el muerto atalarından ona miras kalan bir maske sayesinde insanüstü bir güce sahip olan el muerto nın hikayesini konu ediyor

Ölüm fırtınası storm warning filmi sinemalar com - May 31 2022

web la broma del muerto la cabana del terror de los s 2021 09 26 jaiden kaelyn las mil tribus de homero libros de la vorágine este libro contiene 70 cuentos de 10 autores

el muerto film 2024 beyazperde com - Mar 29 2022

web la broma del muerto la cabana del terror de los s 1 la broma del muerto la cabana del terror de los s thank you utterly much for downloading la broma del muerto la

cpr training with red cross red cross american - Jul 20 2023

web the acs precourse self assessment is an online tool that evaluates a student s knowledge in 3 sections rhythm

recognition pharmacology and practical application

free 2022 cpr bls acls pals study guide - Sep 22 2023

web a pulse begin cpr in a healthcare setting use a bed with a cpr feature or place a cpr board under the patient adjust the bed to an appropriate working height or use a step

first aid practice test 1 american red cross test - Jan 14 2023

web terms in this set 5 you are working as part of a bls team providing care to a patient in cardiac arrest which actions demonstrate critical thinking determining a course of

american red cross cpr test review 2023 - May 06 2022

web nov 8 2023 the certificate of extraordinary personal action is given to individuals like jennifer who step up in an emergency situation and help save a life recipients of this

[cpr first aid elearning](#) - May 18 2023

web the 2021 adult first aid cpr aed blended learning course equips students to recognize and care for a variety of first aid breathing and cardiac emergencies involving adults it is

how to perform cpr red cross american red cross - Jul 28 2021

lifeguard practice test proprofs quiz - Mar 04 2022

web 11 24 2023 11 24 2023 501 w market st akron oh 44303 combines the flexibility of online with hands on training provides full certification start taking your course

[skill sheet cpr for adults american red cross](#) - Aug 21 2023

web how is rescue breathing done american red cross cpr test learn with flashcards games and more for free *cpr aed for professional rescuers and health care providers* - Mar 16 2023

web american red cross cpr training classes give you the information and the skills you need to help adults children and infants during cardiac emergencies whether you choose

american red cross bls course pre assessment flashcards - Oct 11 2022

web stop cpr and check for a pulse mr hernandez has a pulse and is making an effort to breathe but is still unresponsive the monitor shows normal sinus rhythm with a rate of

[cpr test american red cross flashcards quizlet](#) - Oct 23 2023

web american red cross cpr test learn with flashcards games and more for free

[cpr training train cpr with red cross red cross](#) - Dec 13 2022

web oct 21 2020 description the acls precourse self assessment is an online tool that evaluates a student s knowledge in 3

sections rhythm recognition pharmacology and

cpr online classes online cpr class red cross american - Oct 31 2021

web cardiopulmonary resuscitation cpr automated external defibrillator aed basic life support bls als pals babysitting childcare learning how to perform cpr

singapore red cross academy - Aug 09 2022

web dec 27 2022 14 items 1 exam elaborations american red cross bls training lesson 2 exam questions with correct answers 2 exam elaborations bls american red cross

cpr practice test questions and answers cpr certification - Nov 12 2022

web singapore red cross academy conducts a wide range of standard and specialised first aid courses for volunteers and the community to empower them to respond to emergencies

adult first aid cpr aed bl r 21 american red cross - Feb 15 2023

web find out if you re up to speed with your cpr knowledge by taking this free practice cpr test these questions and answers reflect the latest american heart association

online cpr cheat sheet - Apr 05 2022

web the 2021 adult cpr aed course equips students to recognize and care for a variety of breathing and cardiac the content of this review regarding the quality and value of this

cpr renewal recertification red cross - Aug 29 2021

get your official cpr certification red cross - Apr 17 2023

web first aid practice test 1 american red cross test 3 0 27 reviews get a hint 1 although choking is common in infants and children more than die

adult first aid cpr aed bl r 21 american red cross - Dec 01 2021

web official red cross website keep your certifications current our cpr renewal courses make it easy to refresh your skills and maintain your credentials

anything can happen at any time charleston american red - Feb 03 2022

web classes from the american red cross take only a few short hours but can help you save a life when every second counts designed for coaches parents adults and teenagers our

cpr steps perform cpr red cross american red cross - Sep 29 2021

americanredcrosscprpretest - Jun 07 2022

web mar 6 2023 well red cross has almost around 17 million volunteers worldwide but being a volunteer takes a mandatory certification exam which ensures if you are ready to

cpr aed first aid test american red cross flashcards - Jun 19 2023

web this cpr aed for professional rescuers and health care providers handbook is part of the american red cross cpr aed for professional rescuers and health care providers

adult cpr aed r 21 san diego ca red cross american red - Jan 02 2022

web learn the right cpr steps our printable guide lists the steps for performing cpr correctly so you can help someone in need 10 off and free shipping on all training

als american red cross flashcards quizlet - Jul 08 2022

web cpr answer key american red cross online cpr cheat sheet online review questions bls study guide quizlet bls provider manual 2019 pdf free first aid acs pretest

acs precourse self assessment american heart association - Sep 10 2022

web american red cross lifeguard exam feb 03 2023 this practice test includes 140 multiple choice test questions about american red cross lifeguard exam the test has been

benji official trailer hd netflix youtube - Jul 13 2023

web feb 12 2018 benji official trailer hd netflix everyone s favorite pawsome hero is coming home to netflix in this brand new family film join benji as he proves to the world that with love and

best online pet shop in singapore pet food store singapore - Oct 16 2023

web benji pet is one of the best pet shops in singapore we carry a full range of pet food treats toys supplements nutrition and healthcare at the lowest price with free delivery tel 6342 3383 93

benji 2018 imdb - Jun 12 2023

web mar 16 2018 benji directed by brandon camp with gabriel bateman darby camp kiele sanchez gralen bryant banks two school kids strike up a friendship with an orphaned puppy named benji when danger befalls them and they end up kidnapped by robbers who are in over their heads benji and his scruffy sidekick come to the rescue

benji wikipedia - Sep 15 2023

web benji is a fictional canine character created by joe camp he has been the focus of several feature films and other media beginning with the independently produced 1974 film benji is a small golden mixed breed dog with a knack for being in the right place at the right time usually to help someone overcome a problem

benji 2018 movie review common sense media - Feb 08 2023

web read more a lot or a little what you will and won t find in this movie educational value not present meant to entertain

rather than educate positive messages resourcefulness and perseverance surmount all obst positive role models central character a dog is heroic determine violence scariness

all 6 benji movies ranked from worst to best photos - Mar 09 2023

web aug 25 2022 oh heavenly dog 1980 chevy chase is a private detective who gets killed but comes back to solve his own murder in the body of benji a dog who was just about to die in a car accident anyway

[benji movies imdb](#) - Jan 07 2023

web benji i 2018 tv pg 87 min crime drama family 6 3 rate 53 metascore two school kids strike up a friendship with an orphaned puppy named benji when danger befalls them and they end up kidnapped by robbers who are in over their heads benji and his scruffy sidekick come to the rescue director brandon camp stars gabriel

benji 1974 film wikipedia - Apr 10 2023

web benji is a 1974 american family film written produced and directed by joe camp it is the first in a series of five films about the golden mixed breed dog named benji filmed in and around mckinney and denton in texas the story follows benji a stray but friendly dog who is adored by some of the townspeople including two children

watch benji netflix official site - Aug 14 2023

web benji 2018 maturity rating tv pg 1h 27m kids a determined dog comes to the rescue and helps heal a broken family when a young boy and his sister stumble into some serious danger starring gabriel bateman darby camp kiele sanchez

benji 2018 film wikipedia - May 11 2023

web benji is a 2018 american adventure drama film written and directed by brandon camp and produced by blumhouse productions the film is a reboot of the 1974 film of the same title which was directed by camp s father joe it stars gabriel bateman and darby camp jason blum served as a producer through his blumhouse productions label