

# Universal Bill Acceptor UBA-1X-SS Service Manual

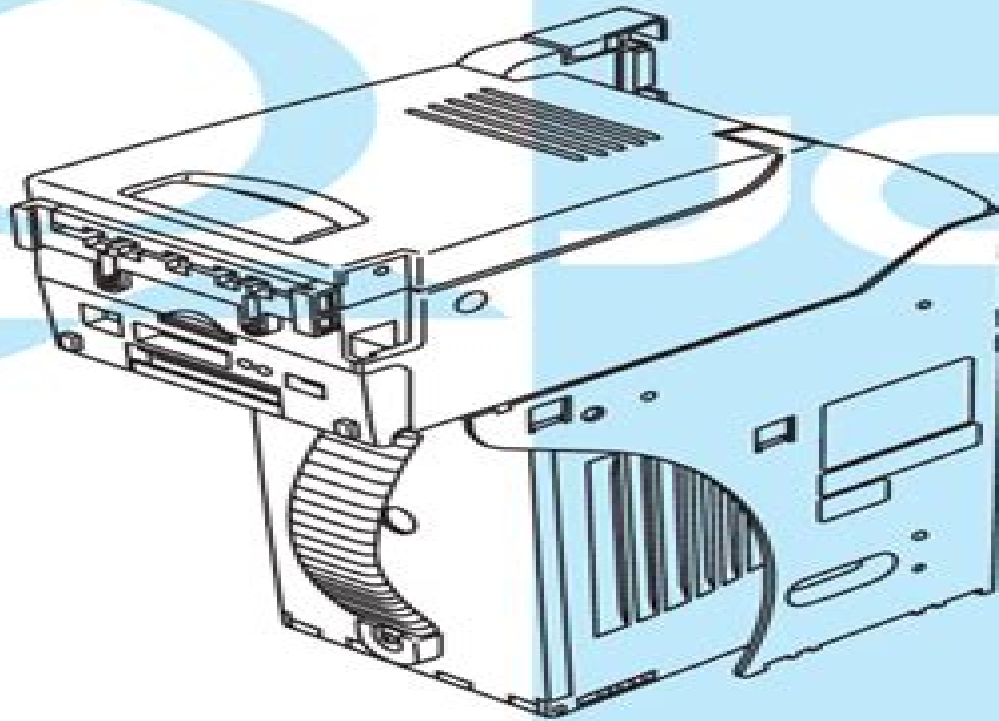

Issue 05/2006



**JAPAN CASH MACHINE CO., LTD.**

Copyright © 2005 Japan Cash Machine Co., Ltd. All rights reserved.

# Jcm Service Manual Eb 200

**J Rink**



## **Jcm Service Manual Eb 200:**

Poor's Manual of the Railroads of the United States ,1914 With an appendix containing a full analysis of the debts of the United States the several states municipalities etc Also statements of street railway and traction companies industrial corporations etc statement omitted on later vols *Moody's Manual of Railroads and Corporation Securities* ,1915

Poor's Manual of Railroads ,1914 With an appendix containing a full analysis of the debts of the United States the several states municipalities etc Also statements of street railway and traction companies industrial corporations etc statement omitted on later vols **Moody's Manual of Industrial and Miscellaneous Securities** ,1915 *Moody's Manual of Railroads and Corporation Securities. Government, State and Municipal Supplement* ,1915 Autocar ,2001

**Brocklehurst's Textbook of Geriatric Medicine and Gerontology E-Book** Howard M. Fillit,Kenneth Rockwood,John B Young,2016-05-06 The leading reference in the field of geriatric care Brocklehurst s Textbook of Geriatric Medicine and Gerontology 8th Edition provides a contemporary global perspective on topics of importance to today s gerontologists internal medicine physicians and family doctors An increased focus on frailty along with coverage of key issues in gerontology disease specific geriatrics and complex syndromes specific to the elderly makes this 8th Edition the reference you ll turn to in order to meet the unique challenges posed by this growing patient population Consistent discussions of clinical manifestations diagnosis prevention treatment and more make reference quick and easy More than 250 figures including algorithms photographs and tables complement the text and help you find what you need on a given condition Clinical relevance of the latest scientific findings helps you easily apply the material to everyday practice A new chapter on frailty plus an emphasis on frailty throughout the book addresses the complex medical and social issues that affect care and the specific knowledge and skills essential for meeting your patients complex needs New content brings you up to date with information on gerontechnology emergency and pre hospital care HIV and aging intensive treatment of older adults telemedicine the built environment and transcultural geriatrics New editor Professor John Young brings a fresh perspective and unique expertise to this edition **Moody's Manual of Investments, American and Foreign** ,1935 **Moody's Manual of Investments** John Sherman Porter,1942 American government securities 1928 53 in 5 annual vols v 1 Railroad securities 1952 53 Transportation v 2 Industrial securities v 3 Public utility securities v 4 Government securities 1928 54 v 5 Banks insurance companies investment trusts real estate finance and credit companies 1928 54 **An Almanack for the Year of Our Lord ...** Joseph Whitaker,1906 *Book Chat* William George Jordan,Adr Schade van Westrum,1886 An Almanack for the Year of Our Lord ... Joseph Whitaker,1906 *Whitaker's Cumulative Book List* ,1931 **British Books in Print** ,1967 **Cumulated Magazine Subject Index, 1907-1949: Jewf-Z** Frederick Winthrop Faxon,1964 New Zealand Books in Print ,1986 *B100, B200, B300, CB300 and MB300 Compact Service Manual* Chrysler Motors Corp. Dodge Division,19?? **Yamaha BW200E(S) Supplementary Service Manual** ,1985 *B100, B200, B300, CB300 and*

*MB300 Compact Service Manual* Chrysler Corporation. Dodge Division, 1973\*  
,2008-01-01

**Chilton Chrysler Service Manual**

Right here, we have countless ebook **Jcm Service Manual Eb 200** and collections to check out. We additionally have the funds for variant types and then type of the books to browse. The standard book, fiction, history, novel, scientific research, as without difficulty as various supplementary sorts of books are readily to hand here.

As this Jcm Service Manual Eb 200, it ends going on swine one of the favored books Jcm Service Manual Eb 200 collections that we have. This is why you remain in the best website to see the unbelievable ebook to have.

[https://staging.conocer.cide.edu/public/book-search/default.aspx/human\\_resources\\_technician\\_study\\_guide.pdf](https://staging.conocer.cide.edu/public/book-search/default.aspx/human_resources_technician_study_guide.pdf)

## **Table of Contents Jcm Service Manual Eb 200**

1. Understanding the eBook Jcm Service Manual Eb 200
  - The Rise of Digital Reading Jcm Service Manual Eb 200
  - Advantages of eBooks Over Traditional Books
2. Identifying Jcm Service Manual Eb 200
  - Exploring Different Genres
  - Considering Fiction vs. Non-Fiction
  - Determining Your Reading Goals
3. Choosing the Right eBook Platform
  - Popular eBook Platforms
  - Features to Look for in an Jcm Service Manual Eb 200
  - User-Friendly Interface
4. Exploring eBook Recommendations from Jcm Service Manual Eb 200
  - Personalized Recommendations
  - Jcm Service Manual Eb 200 User Reviews and Ratings
  - Jcm Service Manual Eb 200 and Bestseller Lists
5. Accessing Jcm Service Manual Eb 200 Free and Paid eBooks
  - Jcm Service Manual Eb 200 Public Domain eBooks

- Jcm Service Manual Eb 200 eBook Subscription Services
- Jcm Service Manual Eb 200 Budget-Friendly Options
- 6. Navigating Jcm Service Manual Eb 200 eBook Formats
  - ePub, PDF, MOBI, and More
  - Jcm Service Manual Eb 200 Compatibility with Devices
  - Jcm Service Manual Eb 200 Enhanced eBook Features
- 7. Enhancing Your Reading Experience
  - Adjustable Fonts and Text Sizes of Jcm Service Manual Eb 200
  - Highlighting and Note-Taking Jcm Service Manual Eb 200
  - Interactive Elements Jcm Service Manual Eb 200
- 8. Staying Engaged with Jcm Service Manual Eb 200
  - Joining Online Reading Communities
  - Participating in Virtual Book Clubs
  - Following Authors and Publishers Jcm Service Manual Eb 200
- 9. Balancing eBooks and Physical Books Jcm Service Manual Eb 200
  - Benefits of a Digital Library
  - Creating a Diverse Reading Collection Jcm Service Manual Eb 200
- 10. Overcoming Reading Challenges
  - Dealing with Digital Eye Strain
  - Minimizing Distractions
  - Managing Screen Time
- 11. Cultivating a Reading Routine Jcm Service Manual Eb 200
  - Setting Reading Goals Jcm Service Manual Eb 200
  - Carving Out Dedicated Reading Time
- 12. Sourcing Reliable Information of Jcm Service Manual Eb 200
  - Fact-Checking eBook Content of Jcm Service Manual Eb 200
  - Distinguishing Credible Sources
- 13. Promoting Lifelong Learning
  - Utilizing eBooks for Skill Development
  - Exploring Educational eBooks

#### 14. Embracing eBook Trends

- Integration of Multimedia Elements
- Interactive and Gamified eBooks

### **Jcm Service Manual Eb 200 Introduction**

Free PDF Books and Manuals for Download: Unlocking Knowledge at Your Fingertips In today's fast-paced digital age, obtaining valuable knowledge has become easier than ever. Thanks to the internet, a vast array of books and manuals are now available for free download in PDF format. Whether you are a student, professional, or simply an avid reader, this treasure trove of downloadable resources offers a wealth of information, conveniently accessible anytime, anywhere. The advent of online libraries and platforms dedicated to sharing knowledge has revolutionized the way we consume information. No longer confined to physical libraries or bookstores, readers can now access an extensive collection of digital books and manuals with just a few clicks. These resources, available in PDF, Microsoft Word, and PowerPoint formats, cater to a wide range of interests, including literature, technology, science, history, and much more. One notable platform where you can explore and download free Jcm Service Manual Eb 200 PDF books and manuals is the internet's largest free library. Hosted online, this catalog compiles a vast assortment of documents, making it a veritable goldmine of knowledge. With its easy-to-use website interface and customizable PDF generator, this platform offers a user-friendly experience, allowing individuals to effortlessly navigate and access the information they seek. The availability of free PDF books and manuals on this platform demonstrates its commitment to democratizing education and empowering individuals with the tools needed to succeed in their chosen fields. It allows anyone, regardless of their background or financial limitations, to expand their horizons and gain insights from experts in various disciplines. One of the most significant advantages of downloading PDF books and manuals lies in their portability. Unlike physical copies, digital books can be stored and carried on a single device, such as a tablet or smartphone, saving valuable space and weight. This convenience makes it possible for readers to have their entire library at their fingertips, whether they are commuting, traveling, or simply enjoying a lazy afternoon at home. Additionally, digital files are easily searchable, enabling readers to locate specific information within seconds. With a few keystrokes, users can search for keywords, topics, or phrases, making research and finding relevant information a breeze. This efficiency saves time and effort, streamlining the learning process and allowing individuals to focus on extracting the information they need. Furthermore, the availability of free PDF books and manuals fosters a culture of continuous learning. By removing financial barriers, more people can access educational resources and pursue lifelong learning, contributing to personal growth and professional development. This democratization of knowledge promotes intellectual curiosity and empowers individuals to become lifelong learners, promoting progress and innovation in various fields. It is worth noting that while

accessing free Jcm Service Manual Eb 200 PDF books and manuals is convenient and cost-effective, it is vital to respect copyright laws and intellectual property rights. Platforms offering free downloads often operate within legal boundaries, ensuring that the materials they provide are either in the public domain or authorized for distribution. By adhering to copyright laws, users can enjoy the benefits of free access to knowledge while supporting the authors and publishers who make these resources available. In conclusion, the availability of Jcm Service Manual Eb 200 free PDF books and manuals for download has revolutionized the way we access and consume knowledge. With just a few clicks, individuals can explore a vast collection of resources across different disciplines, all free of charge. This accessibility empowers individuals to become lifelong learners, contributing to personal growth, professional development, and the advancement of society as a whole. So why not unlock a world of knowledge today? Start exploring the vast sea of free PDF books and manuals waiting to be discovered right at your fingertips.

### **FAQs About Jcm Service Manual Eb 200 Books**

How do I know which eBook platform is the best for me? Finding the best eBook platform depends on your reading preferences and device compatibility. Research different platforms, read user reviews, and explore their features before making a choice. Are free eBooks of good quality? Yes, many reputable platforms offer high-quality free eBooks, including classics and public domain works. However, make sure to verify the source to ensure the eBook credibility. Can I read eBooks without an eReader? Absolutely! Most eBook platforms offer web-based readers or mobile apps that allow you to read eBooks on your computer, tablet, or smartphone. How do I avoid digital eye strain while reading eBooks? To prevent digital eye strain, take regular breaks, adjust the font size and background color, and ensure proper lighting while reading eBooks. What the advantage of interactive eBooks? Interactive eBooks incorporate multimedia elements, quizzes, and activities, enhancing the reader engagement and providing a more immersive learning experience. Jcm Service Manual Eb 200 is one of the best book in our library for free trial. We provide copy of Jcm Service Manual Eb 200 in digital format, so the resources that you find are reliable. There are also many Ebooks of related with Jcm Service Manual Eb 200. Where to download Jcm Service Manual Eb 200 online for free? Are you looking for Jcm Service Manual Eb 200 PDF? This is definitely going to save you time and cash in something you should think about.

**Find Jcm Service Manual Eb 200 :  
human resources technician study guide**



**human physiology 8th edition**

**humiliate me pleasemm bdsm stories english edition**

~~human geography william norton 8th edition~~

huntress moon the huntressfbi thrillers book english edition

**hurst review booklet 2014 answers**

~~hunter 44550 user manual~~

**human physiology stuart ira fox 13th edition**

humminbird 786ci gps owners manual

husqvarna chainsaw 51 manual

**husqvarna chainsaw 385xp full service repair manual**

~~husband is my toilet slave~~

~~hunger in america the federal response~~

hundreds chart 200 300

hurricane katrina writing papers

## **Jcm Service Manual Eb 200 :**

**english in mind level 2b combo 2b with dvd rom** - Jan 05 2023

web english in mind combo 2b with dvd rom features a new welcome unit and units 8 14 from the full student s book

renumbered as units 1 8 together with their corresponding

*english in mind level 2b combo 2b with dvd rom paperback* - Nov 03 2022

web amazon in buy english in mind level 2b combo 2b with dvd rom book online at best prices in india on amazon in read

english in mind level 2b combo 2b with dvd

**english in mind combo 2b with dvd rom level 2b** - May 29 2022

web english in mind combo 2b with dvd rom level 2b рсд 1 490 00 this second edition updates a course which has proven to be a perfect fit for classes the world over

*english mind 2a2b combo abebooks* - Oct 02 2022

web english in mind level 2b combo 2b with dvd rom by stranks jeff and a great selection of related books art and collectibles available now at abebooks co uk

**english in mind level 2 second edition freedownloadmanager** - Jun 29 2022

web nov 10 2022 english in mind combo 2a with dvd rom features the welcome unit and units 1 7 from the full student 039 s

book renumbered as units 1 8 together with their

*english in mind level 2b combo 2b with dvd rom* - Dec 04 2022

web this revised second edition updates a course which has proven to be a perfect fit for classes the world over english in mind combo 2b with dvd rom features a new welcome

english in mind level 2b combo with audio cd cd rom - Sep 01 2022

web jul 9 2007 english in mind level 2b combo with audio cd cd rom herbert puchta jeff stranks richard carter peter lewis jones cambridge university press jul 9 2007

*english in mind level 2b combo 2b with dvd rom softcover* - Aug 12 2023

web english in mind level 2b combo 2b with dvd rom by puchta herbert stranks jeff isbn 10 0521183308 isbn 13 9780521183307 cambridge university press 2011

**english in mind combo 2b dvd rom cyberlab sutd edu sg** - Jan 25 2022

web the english unlimited upper intermediate b combo with dvd rom includes coursebook units 8 to 14 as well as the e portfolio and self study dvd rom english unlimited

*cambridge university press assessment secondary* - Mar 27 2022

web english in mind level 2b this second edition updates a course which has proven to be a perfect fit for classes the world over herbert puchta jeff stranks

**english in mind 2 sb class audio wb wb cd free download** - Dec 24 2021

web aug 17 2017 free download english in mind 2 student s book class audio workbook workbook cd pdf mp3 ogg written for teenagers english in mind creates an

*english in mind secondary cambridge university press* - Jul 31 2022

web popular course features have been refreshed with new content including the imaginative reading and listening topics culture in mind and everyday english sections brand

*english in mind level 2b combo 2b with dvd rom english* - Apr 08 2023

web english in mind level 2b combo 2b with dvd rom by puchta herbert from flipkart com only genuine products 30 day replacement guarantee free shipping cash on delivery

**english in mind level 2b combo 2b with dvd rom** - May 09 2023

web feb 10 2011 get free shipping on english in mind level 2b combo 2b with dvd rom by herbert puchta from wordery com this second edition updates a course which has

**english in mind level 2b combo 2b with dvd rom alibris** - Jul 11 2023

web buy english in mind level 2b combo 2b with dvd rom by herbert puchta jeff stranks online at alibris we have new and

used copies available in 1 editions starting at

*english in mind second edition combo with dvd rom level 2b* - Mar 07 2023

web home english in mind second edition combo with dvd rom level 2b advanced search your shopping cart your cart is empty featured items bestselling adult

**english in mind 2 workbook audio cd cd rom cambridge** - Feb 23 2022

web jan 1 2004 english in mind 2 workbook audio cd cd rom by cambridge publication date 2004 01 01 usage cc0 1 0 universal topics english in mind workbook

**english in mind level 2b combo with audio cd cd rom** - Apr 27 2022

web jul 9 2007 buy english in mind level 2b combo with audio cd cd rom reprint student workbook by puchta herbert stranks jeff carter richard lewis jones

english in mind level 2b combo 2b with dvd rom amazon com - Sep 13 2023

web aug 22 2011 english in mind combo 2b with dvd rom features a new welcome unit and units 8 14 from the full student s book renumbered as units 1 8 together with their

english in mind level 2b combo 2b with dvd rom paperback - Feb 06 2023

web buy english in mind level 2b combo 2b with dvd rom 2 by puchta herbert stranks jeff isbn 9780521183307 from amazon s book store everyday low prices and free

english in mind level 2b combo 2b with dvd rom paperback - Oct 14 2023

web english in mind level 2b combo 2b with dvd rom puchta herbert stranks jeff amazon sg books

english in mind second edition 1 sb audio cd rom free - Nov 22 2021

web aug 20 2017 english in mind second edition 1 student s book class audio cd testmaker cd rom audio cd free download english in mind second edition 1

**english in mind level 2b combo 2b with dvd rom goodreads** - Jun 10 2023

web english in mind combo 2b with dvd rom features a new welcome unit and units 8 14 from the full student s book renumbered as units 1 8 together with their corresponding

the baha i faith the emerging global religion wikipedia - Aug 15 2023

web the baha i faith the emerging global religion is a 1984 book written by william hatcher and douglas martin on the baha i religion the book has been designated by the encyclopaedia britannica as one of the ten books of the year that have made significant contributions to knowledge and understanding in the domain of religion

**the baha i faith the emerging global religion book** - Oct 05 2022

web the baha i faith the emerging global religion is a 1984 book written by william hatcher and douglas martin on the baha i

religion the book has been designated by the encyclopaedia britannica as one of the ten books of the year that have made significant contributions to knowledge and understanding in the domain of religion

**the baha i faith the emerging global religion paperback** - Sep 04 2022

web buy the baha i faith the emerging global religion new by hatcher william isbn 9781931847063 from amazon s book store everyday low prices and free delivery on eligible orders the baha i faith the emerging global religion amazon co uk hatcher william 9781931847063 books

**the bahá í faith the emerging global religion hatcher william s** - May 12 2023

web the bahá í faith the emerging global religion by hatcher william s martin j douglas james douglas

*the bahá í faith the emerging global religion william s* - Mar 30 2022

web explore the history teachings structure and community life of the world wide baha i community what may well be the most diverse organized body of people on earth through this revised and updated comprehensive introduction 2002

**the baha i faith the emerging global religion amazon com tr** - Mar 10 2023

web the baha i faith the emerging global religion hatcher william amazon com tr kitap

**the baha i faith** - Feb 26 2022

web the baha i faith the emerging global religion by william s hatcher and douglas martin wilmette bahá í publishing trust 1985 2011 1 english version e book available

**the bahá í faith the emerging global religion william s hatcher** - Apr 11 2023

web jan 1 1985 this book written by william s hatcher and j douglas martin offers an overview of the baha i faith and then focuses on it role as an emerging global religion it has served as a core secondary source for a research paper i am writing and has been the most relevant to the thesis of my paper

**the baha i faith the emerging global religion goodreads** - Dec 07 2022

web jul 1 1990 the baha i faith the emerging global religion william s hatcher douglas martin 3 93 69 ratings8 reviews explore the history teachings structure and community life of the world wide baha i community what may well be the most diverse organized body of people on earth through this revised and updated comprehensive introduction 2002

*the baha i faith the emerging global religion google books* - Jan 08 2023

web explore the history teachings structure and community life of the world wide baha i community what may well be the most diverse organized body of people on earth through this revised and

*the bahá í faith the emerging global religion worldcat org* - Feb 09 2023

web this is a study of the history teachings administrative structure and community life of the baha i faith the youngest and fastest growing of the world s independent religions

*the baha i faith the emerging global religion amazon com* - Jul 14 2023

web jan 1 2002 this book written by william s hatcher and j douglas martin offers an overview of the baha i faith and then focuses on it role as an emerging global religion it has served as a core secondary source for a research paper i am writing and has been the most relevant to the thesis of my paper

**free the bahai faith the emerging global religion engl** - Jan 28 2022

web apr 4 2023 the bahai faith the emerging global religion engl pantheon aug 16 2020 from one of the world s leading authorities on the subject an innovative and comprehensive account of religion in the ancient roman and mediterranean world in this ambitious and authoritative book jörg

baha i faith in turkey the religion and public life at harvard - Jun 01 2022

web turkey has a longstanding baha i faith community which today numbers roughly 10 000 the baha i faith was founded in 19 th century iran by mirza hosayn ali nuri baha ullah d 1892 and developed from babism an iranian messianic movement and shi a shaikhism baha is acknowledge numerous prophets including muhammad jesus krishna

**the baha faith the emerging global religion paperback** - Nov 06 2022

web named by the encyclopedia britannica as a book that has made significant contributions to the knowledge and understanding of religious thought the baha i faith covers the most recent developments in a faith that in just over 150 years has grown to become the second most wide spread of the independent world religions

*the baha i faith the emerging global religion alibris* - Apr 30 2022

web named by the encyclopedia britannica as a book that has made significant contributions to the knowledge and understanding of religious thought the baha i faith covers the most recent developments in a faith that in just over 150 years has grown to become the second most wide spread of the all from 1 45 new books from 7 66

**the baha i faith the emerging global religion google books** - Aug 03 2022

web this is a study of the history teachings administrative structure and community life of the baha i faith the youngest and fastest growing of the world s independent religions from inside the book what people are saying write a review

the bahá í faith the emerging global religion google books - Sep 16 2023

web the bahá í faith the emerging global religion william s hatcher james douglas martin google books explore the history teachings structure and community life of the world wide

baha i faith the emerging global religion hardcover - Jul 02 2022

web buy baha i faith the emerging global religion 3 by hatcher william s martin j douglas isbn 9780877432647 from amazon s book store everyday low prices and free delivery on eligible orders

**the bahá í faith the emerging global religion hatcher william s** - Jun 13 2023

web jan 24 2022 bahai faith publisher wilmette ill bahá í pub trust collection inlibrary printdisabled internetarchivebooks contributor internet archive language english

von cheffinnen und prinzeßinnen zwei essays über - Oct 09 2023

web von cheffinnen und prinzeßinnen zwei essays über frauenfiguren in film und fernsehen roeller antonia amazon de bücher 9783946930020 von cheffinnen und prinzeßinnen zwei essays über - Jun 05 2023

web von cheffinnen und prinzeßinnen zwei essays über frauenfiguren in film und fernsehen finden sie alle bücher von roeller antonia bei der büchersuchmaschine eurobuch at können sie antiquarische und neubücher vergleichen und sofort zum bestpreis bestellen 9783946930020

**von cheffinnen und prinzeßinnen zwei essays uber** - Jul 06 2023

web von cheffinnen und prinzeßinnen zwei essays uber 3 3 andere zeit alexandra von stein gewährt uns einblicke in die kindheits und jugenderinnerungen ihrer großmutter doris von auerswald die 1891 geboren in westpreußen aufwuchs und einen großen teil ihrer kindheit auf dem gut ihrer großeltern verbrachte angeregt durch die lebendigen und *kulinarischer lesegenuss deutschlandfunk kultur* - Apr 22 2022

web dec 7 2017 roman einer köchin von marie ndiaye einer französischen autorin in dem buch geht es um eine frau die aus sehr sehr ärmlichen verhältnissen kommt vom land in der nähe von bordeaux

**frauenbilder in film und serie master school drehbuch e k** - May 04 2023

web jan 23 2017 die beiden essays von antonia roeller über frauenfiguren im aktuellen film und tv haben wir unter dem titel von cheffinnen und prinzeßinnen in einem buch zusammengefügt Über dieses buch wie hat sich das bild von weiblichen führungskräften in film und fernsehen verändert

**von cheffinnen und prinzeßinnen zwei essays über** - Apr 03 2023

web search for resources documents and more search english

von cheffinnen und prinzeßinnen zwei essays über goodreads - Sep 08 2023

web von cheffinnen und prinzeßinnen zwei essays über frauenfiguren in film und fernsehen book read reviews from world s largest community for readers wie h

*von cheffinnen und prinzeßinnen zwei essays über* - Aug 07 2023

web von cheffinnen und prinzeßinnen zwei essays über frauenfiguren in film und fernsehen on amazon com au free shipping on eligible orders von cheffinnen und prinzeßinnen zwei essays über frauenfiguren in film und fernsehen

*weitere informationen von cheffinnen und prinzeßinnen* - Dec 31 2022

web von cheffinnen und prinzeßinnen zwei essays über frauenfiguren in film und fernsehen

**von cheffinnen und prinzeßinnen orell füssli** - Feb 01 2023

web jetzt online bestellen heimlieferung oder in filiale von cheffinnen und prinzeßinnen zwei essays über frauenfiguren in film und fernsehen von antonia roeller orell füßli der buchhändler ihres vertrauens

**prinzessin auf türkisch übersetzen deutsch tuerkisch net** - Jun 24 2022

web deutsch tuerkisch net prinzeßin auf türkisch übersetzen prinzeßin deutsch türkische übersetzung prinzeßin in türkisch **von cheffinnen und prinzeßinnen zwei essays über f buch** - Sep 27 2022

web entdecken sie von cheffinnen und prinzeßinnen zwei essays über f buch zustand sehr gut in der großen auswahl bei ebay kostenlose lieferung für viele artikel

**von cheffinnen und prinzeßinnen zwei essays über** - Feb 18 2022

web von cheffinnen und prinzeßinnen zwei essays über frauenfiguren in film und fernsehen by antonia roeller theaterstücken und romanen seit einigen jahren beschäftigt sie sich intensiv mit frauenfiguren in film und fernsehen sie unterrichtete ein seminar zur entwicklung komplexer leinwandheldinnen an der master school drehbuch

*prinzessin deutsch türkisch Übersetzung pons* - Jul 26 2022

web Übersetzung deutsch türkisch für prinzeßin im pons online wörterbuch nachschlagen gratis vokabeltrainer verbtabeln aussprachefunktion

**briefe schreiben b2 teil 2 von illya kozyrev bücher orell füßli** - Mar 22 2022

web dieses buch will schülerinnen und schülern helfen die einen integrationskurs deutsch mit dem dtz a2 b1 abschluss bereits bestanden haben und gerade einen b2 kurs beginnen es geht hier um den schriftlichen ausdrück im bereich b2 den man sich mit hilfe von briefen mit wichtigen alltagsthemen durch einsetzübungen mühelos erwerben kann

*von cheffinnen und prinzeßinnen zwei essays über* - Aug 27 2022

web prinzeßinnen wieso weshalb warum band 15 154c von cheffinnen und prinzeßinnen zwei essays über die drei schönen prinzeßinnen internet maerchen de es war einmal eine prinzeßin welt was macht die prinzeßin buch versandkostenfrei bei prinzeßinnen geschichten zum ausdrücken für kinder hey leute hat mir jemand

*von cheffinnen und prinzeßinnen zwei essays über* - Nov 29 2022

web von cheffinnen und prinzeßinnen zwei essays über höfische erlebnisse apr 08 2021 philipp zu eulenburg war ein preußischer diplomat und enger vertrauter des deutschen kaisers wilhelm ii in seinen geschichten finden sich die höfe und adligen der zeit um die vorletzte jahrhundertwende

**master school drehbuch edition drehbuchkurse online und in** - Mar 02 2023

web von cheffinnen und prinzeßinnen zwei essays über frauenfiguren in film und fernsehen von antonia roeller als print version paperback 108 seiten 9 99 veröffentlicht november 2016 isbn 978 3 946930 02 0 print karrieresüchtig machtversessen einsam die darstellung weiblicher führungskräfte in film und

**pdf von cheffinnen und prinzeffinnen zwei essays uber** - Oct 29 2022

web von cheffinnen und prinzeffinnen zwei essays uber prinzeffin kate jan 11 2021 es ist eine moderne cinderella geschichte das bürgerliche mädchen das zur prinzeffin wird durch die traumhochzeit von prinz william und kate middleton auf die die ganze welt acht jahre lang gewartet hat wird dieses märchen wirklichkeit doch wer ist kate

**von cheffinnen und prinzeffinnen zwei essays uber 2022** - May 24 2022

web von cheffinnen und prinzeffinnen zwei essays uber but stop up in harmful downloads rather than enjoying a fine book gone a cup of coffee in the afternoon then again they juggled when some harmful virus inside their computer von cheffinnen und prinzeffinnen zwei essays uber is friendly in our digital library an online entrance to it