

Internal Assembly Locations

Figure 1-6 Internal Assembly Locations (1 of 2)

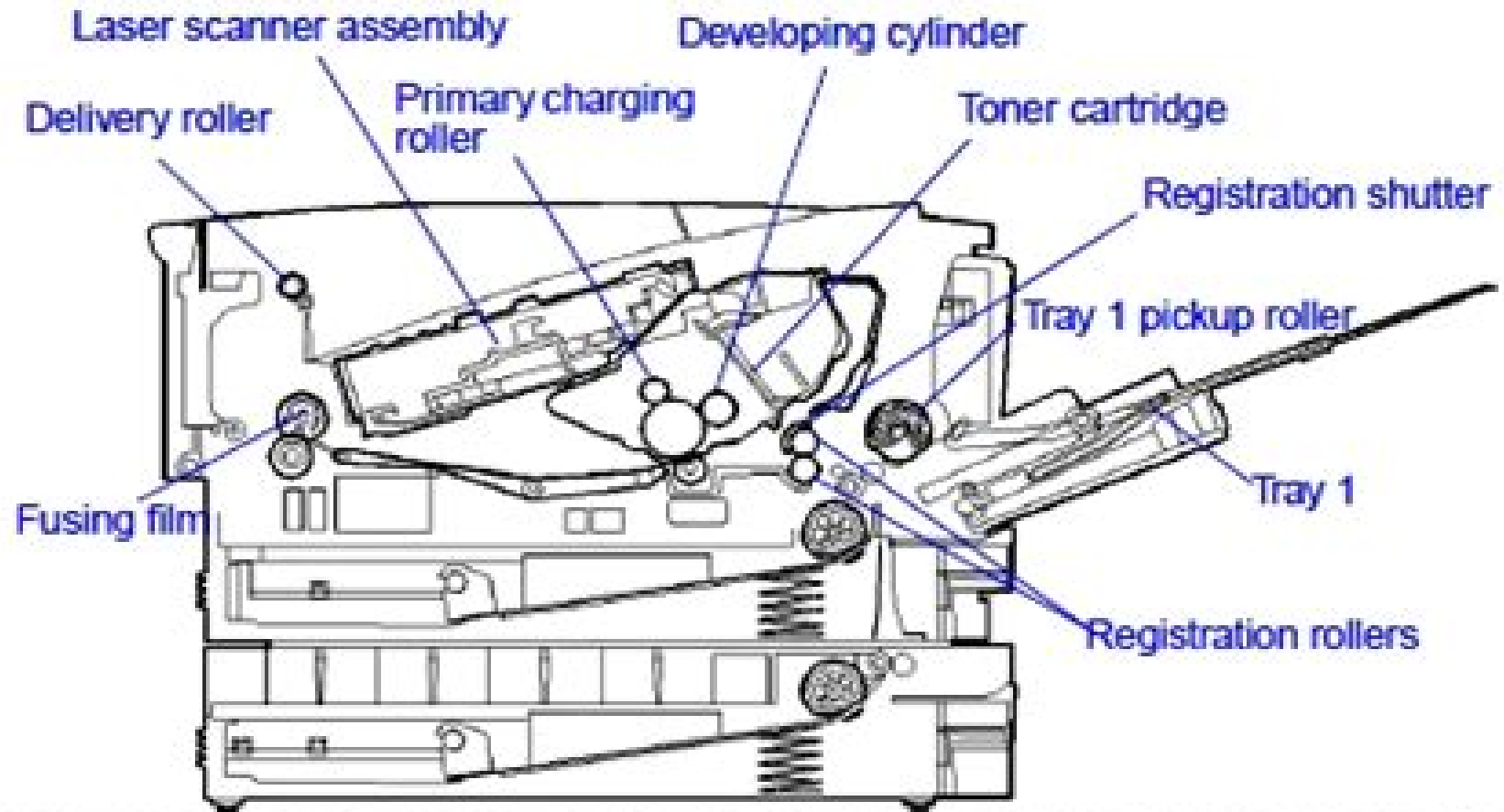

Preview: HP LaserJet 2100 service manual

[Download Now!](#)

Hp Laserjet 2100 Manual

LM Reder



Hp Laserjet 2100 Manual:

Immerse yourself in the artistry of words with is expressive creation, Immerse Yourself in **Hp Laserjet 2100 Manual** . This ebook, presented in a PDF format (Download in PDF: *), is a masterpiece that goes beyond conventional storytelling. Indulge your senses in prose, poetry, and knowledge. Download now to let the beauty of literature and artistry envelop your mind in a unique and expressive way.

https://staging.conocer.cide.edu/About/book-search/HomePages/Just_Start_Lifetime_Wardrobe_Management_System.pdf

Table of Contents Hp Laserjet 2100 Manual

1. Understanding the eBook Hp Laserjet 2100 Manual
 - The Rise of Digital Reading Hp Laserjet 2100 Manual
 - Advantages of eBooks Over Traditional Books
2. Identifying Hp Laserjet 2100 Manual
 - Exploring Different Genres
 - Considering Fiction vs. Non-Fiction
 - Determining Your Reading Goals
3. Choosing the Right eBook Platform
 - Popular eBook Platforms
 - Features to Look for in an Hp Laserjet 2100 Manual
 - User-Friendly Interface
4. Exploring eBook Recommendations from Hp Laserjet 2100 Manual
 - Personalized Recommendations
 - Hp Laserjet 2100 Manual User Reviews and Ratings
 - Hp Laserjet 2100 Manual and Bestseller Lists
5. Accessing Hp Laserjet 2100 Manual Free and Paid eBooks
 - Hp Laserjet 2100 Manual Public Domain eBooks
 - Hp Laserjet 2100 Manual eBook Subscription Services
 - Hp Laserjet 2100 Manual Budget-Friendly Options

6. Navigating Hp Laserjet 2100 Manual eBook Formats
 - ePub, PDF, MOBI, and More
 - Hp Laserjet 2100 Manual Compatibility with Devices
 - Hp Laserjet 2100 Manual Enhanced eBook Features
7. Enhancing Your Reading Experience
 - Adjustable Fonts and Text Sizes of Hp Laserjet 2100 Manual
 - Highlighting and Note-Taking Hp Laserjet 2100 Manual
 - Interactive Elements Hp Laserjet 2100 Manual
8. Staying Engaged with Hp Laserjet 2100 Manual
 - Joining Online Reading Communities
 - Participating in Virtual Book Clubs
 - Following Authors and Publishers Hp Laserjet 2100 Manual
9. Balancing eBooks and Physical Books Hp Laserjet 2100 Manual
 - Benefits of a Digital Library
 - Creating a Diverse Reading Collection Hp Laserjet 2100 Manual
10. Overcoming Reading Challenges
 - Dealing with Digital Eye Strain
 - Minimizing Distractions
 - Managing Screen Time
11. Cultivating a Reading Routine Hp Laserjet 2100 Manual
 - Setting Reading Goals Hp Laserjet 2100 Manual
 - Carving Out Dedicated Reading Time
12. Sourcing Reliable Information of Hp Laserjet 2100 Manual
 - Fact-Checking eBook Content of Hp Laserjet 2100 Manual
 - Distinguishing Credible Sources
13. Promoting Lifelong Learning
 - Utilizing eBooks for Skill Development
 - Exploring Educational eBooks
14. Embracing eBook Trends
 - Integration of Multimedia Elements

- Interactive and Gamified eBooks

Hp Laserjet 2100 Manual Introduction

Free PDF Books and Manuals for Download: Unlocking Knowledge at Your Fingertips In today's fast-paced digital age, obtaining valuable knowledge has become easier than ever. Thanks to the internet, a vast array of books and manuals are now available for free download in PDF format. Whether you are a student, professional, or simply an avid reader, this treasure trove of downloadable resources offers a wealth of information, conveniently accessible anytime, anywhere. The advent of online libraries and platforms dedicated to sharing knowledge has revolutionized the way we consume information. No longer confined to physical libraries or bookstores, readers can now access an extensive collection of digital books and manuals with just a few clicks. These resources, available in PDF, Microsoft Word, and PowerPoint formats, cater to a wide range of interests, including literature, technology, science, history, and much more. One notable platform where you can explore and download free Hp Laserjet 2100 Manual PDF books and manuals is the internet's largest free library. Hosted online, this catalog compiles a vast assortment of documents, making it a veritable goldmine of knowledge. With its easy-to-use website interface and customizable PDF generator, this platform offers a user-friendly experience, allowing individuals to effortlessly navigate and access the information they seek. The availability of free PDF books and manuals on this platform demonstrates its commitment to democratizing education and empowering individuals with the tools needed to succeed in their chosen fields. It allows anyone, regardless of their background or financial limitations, to expand their horizons and gain insights from experts in various disciplines. One of the most significant advantages of downloading PDF books and manuals lies in their portability. Unlike physical copies, digital books can be stored and carried on a single device, such as a tablet or smartphone, saving valuable space and weight. This convenience makes it possible for readers to have their entire library at their fingertips, whether they are commuting, traveling, or simply enjoying a lazy afternoon at home. Additionally, digital files are easily searchable, enabling readers to locate specific information within seconds. With a few keystrokes, users can search for keywords, topics, or phrases, making research and finding relevant information a breeze. This efficiency saves time and effort, streamlining the learning process and allowing individuals to focus on extracting the information they need. Furthermore, the availability of free PDF books and manuals fosters a culture of continuous learning. By removing financial barriers, more people can access educational resources and pursue lifelong learning, contributing to personal growth and professional development. This democratization of knowledge promotes intellectual curiosity and empowers individuals to become lifelong learners, promoting progress and innovation in various fields. It is worth noting that while accessing free Hp Laserjet 2100 Manual PDF books and manuals is convenient and cost-effective, it is vital to respect copyright laws and intellectual property rights. Platforms offering free downloads often operate within legal boundaries,

ensuring that the materials they provide are either in the public domain or authorized for distribution. By adhering to copyright laws, users can enjoy the benefits of free access to knowledge while supporting the authors and publishers who make these resources available. In conclusion, the availability of Hp Laserjet 2100 Manual free PDF books and manuals for download has revolutionized the way we access and consume knowledge. With just a few clicks, individuals can explore a vast collection of resources across different disciplines, all free of charge. This accessibility empowers individuals to become lifelong learners, contributing to personal growth, professional development, and the advancement of society as a whole. So why not unlock a world of knowledge today? Start exploring the vast sea of free PDF books and manuals waiting to be discovered right at your fingertips.

FAQs About Hp Laserjet 2100 Manual Books

1. Where can I buy Hp Laserjet 2100 Manual books? Bookstores: Physical bookstores like Barnes & Noble, Waterstones, and independent local stores. Online Retailers: Amazon, Book Depository, and various online bookstores offer a wide range of books in physical and digital formats.
2. What are the different book formats available? Hardcover: Sturdy and durable, usually more expensive. Paperback: Cheaper, lighter, and more portable than hardcovers. E-books: Digital books available for e-readers like Kindle or software like Apple Books, Kindle, and Google Play Books.
3. How do I choose a Hp Laserjet 2100 Manual book to read? Genres: Consider the genre you enjoy (fiction, non-fiction, mystery, sci-fi, etc.). Recommendations: Ask friends, join book clubs, or explore online reviews and recommendations. Author: If you like a particular author, you might enjoy more of their work.
4. How do I take care of Hp Laserjet 2100 Manual books? Storage: Keep them away from direct sunlight and in a dry environment. Handling: Avoid folding pages, use bookmarks, and handle them with clean hands. Cleaning: Gently dust the covers and pages occasionally.
5. Can I borrow books without buying them? Public Libraries: Local libraries offer a wide range of books for borrowing. Book Swaps: Community book exchanges or online platforms where people exchange books.
6. How can I track my reading progress or manage my book collection? Book Tracking Apps: Goodreads, LibraryThing, and Book Catalogue are popular apps for tracking your reading progress and managing book collections. Spreadsheets: You can create your own spreadsheet to track books read, ratings, and other details.
7. What are Hp Laserjet 2100 Manual audiobooks, and where can I find them? Audiobooks: Audio recordings of books,

perfect for listening while commuting or multitasking. Platforms: Audible, LibriVox, and Google Play Books offer a wide selection of audiobooks.

8. How do I support authors or the book industry? Buy Books: Purchase books from authors or independent bookstores. Reviews: Leave reviews on platforms like Goodreads or Amazon. Promotion: Share your favorite books on social media or recommend them to friends.
9. Are there book clubs or reading communities I can join? Local Clubs: Check for local book clubs in libraries or community centers. Online Communities: Platforms like Goodreads have virtual book clubs and discussion groups.
10. Can I read Hp Laserjet 2100 Manual books for free? Public Domain Books: Many classic books are available for free as they're in the public domain. Free E-books: Some websites offer free e-books legally, like Project Gutenberg or Open Library.

Find Hp Laserjet 2100 Manual :

~~just start lifetime wardrobe management system~~

~~just living poems and prose of the japanese monk tonna~~

~~jukeboxes the golden age~~

~~just tell me you love me~~

~~just a small town girl~~

jurassic park institute dinosaur field guide jurassic park institute hardcover

~~jumping jackdaws~~

~~jukebox the golden age~~

~~julius caesar his the bbc tv shakespeare~~

junky penguin classics

juneau portrait ii

junior sports anthology

~~jumpety-bumpety hop~~

~~julia roberts~~

~~jungle girl the~~

Hp Laserjet 2100 Manual :

Fundamentals of Turbomachinery by Peng, William W. Fundamentals of Turbomachinery by Peng, William W. Fundamentals of Turbomachinery A comprehensive introduction to turbomachines and their applications With up-to-date coverage of all types of turbomachinery for students and practitioners, ... Fundamentals of Turbomachinery - William W. Peng Dec 21, 2007 — A comprehensive introduction to turbomachines and their applications. With up-to-date coverage of all types of turbomachinery for students ... Fundamentals of Turbomachinery - Peng, William W. A comprehensive introduction to turbomachines and their applications. With up-to-date coverage of all types of turbomachinery for students and practitioners ... Fundamentals of Turbomachinery by William W. Peng ... A comprehensive introduction to turbomachines and their applications With up-to-date coverage of all types of turbomachinery for students and practitioners, ... Fundamentals of Turbomachinery - William W. Peng A comprehensive introduction to turbomachines and their applications With up-to-date coverage of all types of turbomachinery for students and practitioners, ... Fundamentals Turbomachinery by William Peng Fundamentals of Turbomachinery by Peng, William W. and a great selection of related books, art and collectibles available now at AbeBooks.com. Fundamentals of Turbomachinery by William W. Peng Dec 21, 2007 — A comprehensive introduction to turbomachines and their applications. With up-to-date coverage of all types of turbomachinery for students ... Fundamentals of Turbomachinery by William W. Peng ... Find the best prices on Fundamentals of Turbomachinery by William W. Peng at BIBLIO | Hardcover | 2007 | Wiley | 1st Edition | 9780470124222. Fundamentals of Turbomachinery Fundamentals of Turbomachinery ; Title: Fundamentals of Turbomachinery ; Author: William W. Peng ; ISBN: 0470124229 / 9780470124222 ; Format: Hard Cover ; Pages: 384 Answer Key Ranking Task Exercises in Physics. 215. Answer Key. Answer Key. Page #. Kinematics Ranking Tasks. 1. Ball Motion Diagrams—Velocity I. ADF. BE. C. 2. Ball Motion ... Ranking Task Exercises In Physics Solutions Manual Pdf Page 1. Ranking Task Exercises In Physics Solutions Manual Pdf. INTRODUCTION Ranking Task Exercises In Physics Solutions Manual Pdf Copy. RANKING TASK EXERCISES IN PHYSICS by TL O'Kuma · 2000 · Cited by 114 — have the same value for the ranking basis; and a place to explain the reasoning for the answer produced. ... Although most of the ranking tasks in this manual ... Ranking Task Exercises in Physics by Hieggelke, Curtis J. I bought this book for the Ranking Tasks. I didn't realize there would be no answers in the book. I feel this should be stated in the description. I didn't ... Answer Key Kinematics Ranking Tasks Ball Motion ... Ranking Task Exercises in Physics 215 Answer Key Answer Key Page # Kinematics Ranking Tasks 1 Ball Motion Diagrams—Velocity I ADF BE C 2 Ball Motion ... Ranking task exercises in physics : student edition Oct 11, 2022 — When students realize that they have given different answers to variations of the same question, they begin to think about why they responded as ... Cars and Barriers- Stopping Time with the Same Force 75 How sure were you of your ranking? (circle one). Basically Guessed. 1. 2. Sure. 3. 4. 5. 6. 75 T. O'Kuma, C. Hieggelke, D. Maloney. Physics Ranking Tasks. 80. Ranking Task Exercises in Physics_finalcr by PM

Vreeland · 2012 — their solutions to ranking task exercises in physics that contained two quantitative variables, the study found that students relied exclusively on ... Ranking Task Exercise in Physics Answer Key View Homework Help - Ranking Task Exercise in Physics Answer Key from PHYS 201 at Claflin University. Ranking Task Exercises In Physics Pdf Fill Ranking Task Exercises In Physics Pdf, Edit online. Sign, fax and printable from PC, iPad, tablet or mobile with pdfFiller Instantly. Try Now! Advanced Mathematics: An Incremental Development Find step-by-step solutions and answers to Advanced Mathematics: An Incremental Development - 9781565770393, as well as thousands of textbooks so you can ... Advanced Math 2e Answer Key & Tests (Saxon... ... Advanced Math 2e Answer Key & Tests (Saxon Advanced Math) (Paperback) - Common · Buy New. \$52.20\$52.20. \$3.99 delivery: Dec 29 - Jan 5. Ships from: BeveledBooks. Saxon Advanced Math - Solutions Manual The Saxon Advanced Math Solutions Manual provides complete, worked out solutions to the Advanced Math textbook and test forms. Recommended for use with the ... Saxon Advanced Math Solutions Manual (2nd edition)* - Store This manual contain solutions to each problem in the Advanced Mathematics textbooks. Early solutions of problems of a particular type contain every step. Saxon Advanced Math 2ED Answer Keys and Tests Saxon Advanced Math 2ED Answer Keys and Tests · \$45.27 · \$45.27 · \$33.95. Rainbow Savings: \$11.32. saxon advanced math solutions manual Although the Homeschool Kit contains all of the answers, the Solutions Manual contains the answers as well as solution details for each problem. Solutions to ... Saxon Advanced Math Answer Key - Store Answer key to all student textbook problem sets. (This item is included in the Saxon Advanced Math set.) Softcover, 159 pages. Saxon Advanced Math Solutions Manual (2nd edition) Detailed solutions to the problems found in Saxon Advanced Math. This Advanced Mathematics text contains detailed solutions to the problems found in Saxon ... Saxon Advanced Math, Answer Key Booklet & Test Forms Title: Saxon Advanced Math, Answer Key Booklet & Test Forms ; Format: Paperback ; Vendor: Saxon Publishing ; Publication Date: 1998 ; Dimensions: 8 1/2 X 11 (inches) Saxon Advanced Math, Answer Key Booklet & Test Forms This book of tests accompanies the Saxon Advanced Mathematics curriculum. A testing schedule and optional student answer forms are also included.