

Source Four LED Series 3,
shown with 26" XDLT lens tube

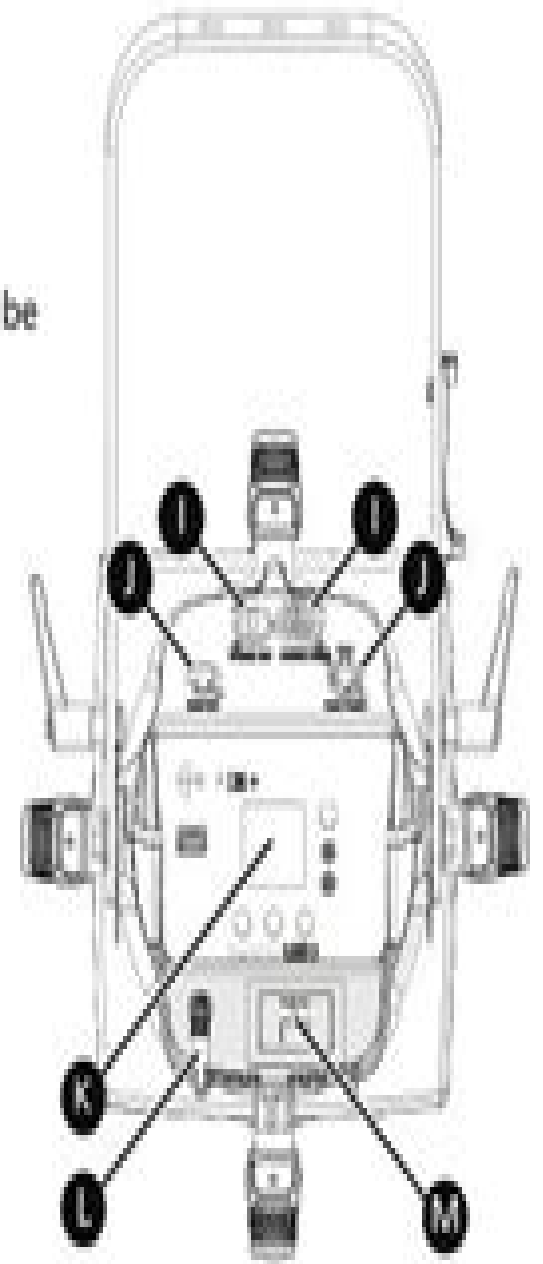

Etc Source Four Assembly Parts Manual User Guide

G Psacharopoulos

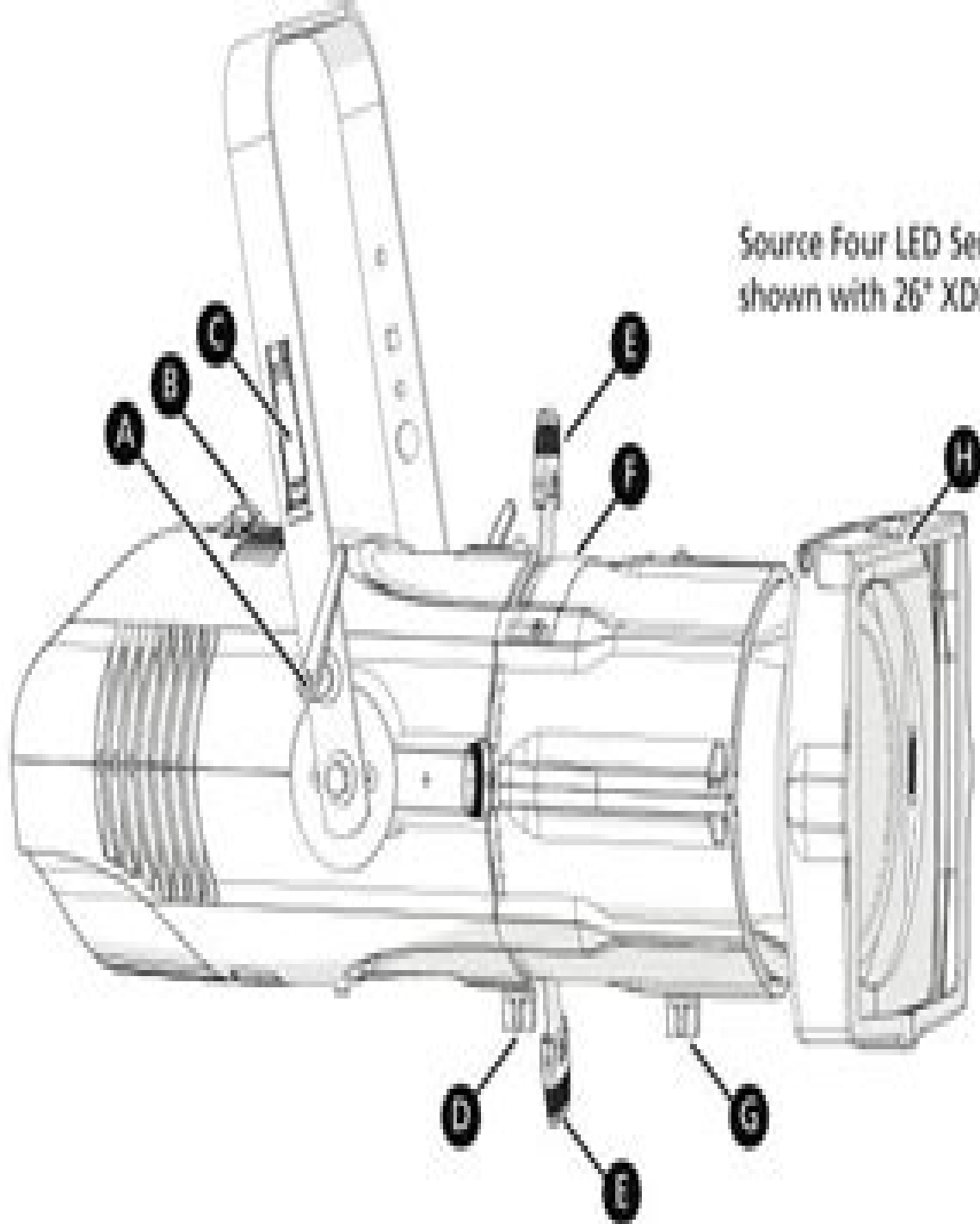

Etc Source Four Assembly Parts Manual User Guide:

Aviation Electronic Officer's Guide United States. Navy Department. Bureau of Aeronautics,1958 *Aviation Electronics Officer's Guide* United States. Office of the Chief of Naval Operations,1958 *Operator, Organizational, Direct and General Support, and Depot Maintenance Manual* ,1973 *User Guide for the Safe Operation of Centrifuges* J. Lindley,Institution of Chemical Engineers (Great Britain),1987 DPI Publications Listing Wisconsin. Department of Public Instruction,1980 **Organizational, DS, GS, and Depot Maintenance Manual (including Repair Parts List)** ,1989
Monthly Catalog of United States Government Publications United States. Superintendent of Documents,1994 February issue includes Appendix entitled Directory of United States Government periodicals and subscription publications September issue includes List of depository libraries June and December issues include semiannual index **Electronics Manual** United States. Coast Guard,1977 **Catalog of Copyright Entries. Part 1. [B] Group 2. Pamphlets, Etc. New Series** Library of Congress. Copyright Office,1946 **All Hands** ,1962

Etc Source Four Assembly Parts Manual User Guide Book Review: Unveiling the Magic of Language

In a digital era where connections and knowledge reign supreme, the enchanting power of language has been apparent than ever. Its power to stir emotions, provoke thought, and instigate transformation is really remarkable. This extraordinary book, aptly titled "**Etc Source Four Assembly Parts Manual User Guide**," written by a highly acclaimed author, immerses readers in a captivating exploration of the significance of language and its profound effect on our existence. Throughout this critique, we shall delve to the book's central themes, evaluate its unique writing style, and assess its overall influence on its readership.

<https://staging.conocer.cide.edu/About/publication/fetch.php/how%20to%20succeed%20in%20academics.pdf>

Table of Contents Etc Source Four Assembly Parts Manual User Guide

1. Understanding the eBook Etc Source Four Assembly Parts Manual User Guide
 - The Rise of Digital Reading Etc Source Four Assembly Parts Manual User Guide
 - Advantages of eBooks Over Traditional Books
2. Identifying Etc Source Four Assembly Parts Manual User Guide
 - Exploring Different Genres
 - Considering Fiction vs. Non-Fiction
 - Determining Your Reading Goals
3. Choosing the Right eBook Platform
 - Popular eBook Platforms
 - Features to Look for in an Etc Source Four Assembly Parts Manual User Guide
 - User-Friendly Interface
4. Exploring eBook Recommendations from Etc Source Four Assembly Parts Manual User Guide
 - Personalized Recommendations
 - Etc Source Four Assembly Parts Manual User Guide User Reviews and Ratings
 - Etc Source Four Assembly Parts Manual User Guide and Bestseller Lists

5. Accessing Etc Source Four Assembly Parts Manual User Guide Free and Paid eBooks
 - Etc Source Four Assembly Parts Manual User Guide Public Domain eBooks
 - Etc Source Four Assembly Parts Manual User Guide eBook Subscription Services
 - Etc Source Four Assembly Parts Manual User Guide Budget-Friendly Options
6. Navigating Etc Source Four Assembly Parts Manual User Guide eBook Formats
 - ePub, PDF, MOBI, and More
 - Etc Source Four Assembly Parts Manual User Guide Compatibility with Devices
 - Etc Source Four Assembly Parts Manual User Guide Enhanced eBook Features
7. Enhancing Your Reading Experience
 - Adjustable Fonts and Text Sizes of Etc Source Four Assembly Parts Manual User Guide
 - Highlighting and Note-Taking Etc Source Four Assembly Parts Manual User Guide
 - Interactive Elements Etc Source Four Assembly Parts Manual User Guide
8. Staying Engaged with Etc Source Four Assembly Parts Manual User Guide
 - Joining Online Reading Communities
 - Participating in Virtual Book Clubs
 - Following Authors and Publishers Etc Source Four Assembly Parts Manual User Guide
9. Balancing eBooks and Physical Books Etc Source Four Assembly Parts Manual User Guide
 - Benefits of a Digital Library
 - Creating a Diverse Reading Collection Etc Source Four Assembly Parts Manual User Guide
10. Overcoming Reading Challenges
 - Dealing with Digital Eye Strain
 - Minimizing Distractions
 - Managing Screen Time
11. Cultivating a Reading Routine Etc Source Four Assembly Parts Manual User Guide
 - Setting Reading Goals Etc Source Four Assembly Parts Manual User Guide
 - Carving Out Dedicated Reading Time
12. Sourcing Reliable Information of Etc Source Four Assembly Parts Manual User Guide
 - Fact-Checking eBook Content of Etc Source Four Assembly Parts Manual User Guide
 - Distinguishing Credible Sources
13. Promoting Lifelong Learning

- Utilizing eBooks for Skill Development
 - Exploring Educational eBooks
14. Embracing eBook Trends
- Integration of Multimedia Elements
 - Interactive and Gamified eBooks

Etc Source Four Assembly Parts Manual User Guide Introduction

In this digital age, the convenience of accessing information at our fingertips has become a necessity. Whether its research papers, eBooks, or user manuals, PDF files have become the preferred format for sharing and reading documents. However, the cost associated with purchasing PDF files can sometimes be a barrier for many individuals and organizations. Thankfully, there are numerous websites and platforms that allow users to download free PDF files legally. In this article, we will explore some of the best platforms to download free PDFs. One of the most popular platforms to download free PDF files is Project Gutenberg. This online library offers over 60,000 free eBooks that are in the public domain. From classic literature to historical documents, Project Gutenberg provides a wide range of PDF files that can be downloaded and enjoyed on various devices. The website is user-friendly and allows users to search for specific titles or browse through different categories. Another reliable platform for downloading Etc Source Four Assembly Parts Manual User Guide free PDF files is Open Library. With its vast collection of over 1 million eBooks, Open Library has something for every reader. The website offers a seamless experience by providing options to borrow or download PDF files. Users simply need to create a free account to access this treasure trove of knowledge. Open Library also allows users to contribute by uploading and sharing their own PDF files, making it a collaborative platform for book enthusiasts. For those interested in academic resources, there are websites dedicated to providing free PDFs of research papers and scientific articles. One such website is Academia.edu, which allows researchers and scholars to share their work with a global audience. Users can download PDF files of research papers, theses, and dissertations covering a wide range of subjects. Academia.edu also provides a platform for discussions and networking within the academic community. When it comes to downloading Etc Source Four Assembly Parts Manual User Guide free PDF files of magazines, brochures, and catalogs, Issuu is a popular choice. This digital publishing platform hosts a vast collection of publications from around the world. Users can search for specific titles or explore various categories and genres. Issuu offers a seamless reading experience with its user-friendly interface and allows users to download PDF files for offline reading. Apart from dedicated platforms, search engines also play a crucial role in finding free PDF files. Google, for instance, has an advanced search feature that allows users to filter results by file type. By specifying the file type as "PDF," users can find websites that offer free PDF downloads on a specific topic. While downloading Etc

Source Four Assembly Parts Manual User Guide free PDF files is convenient, its important to note that copyright laws must be respected. Always ensure that the PDF files you download are legally available for free. Many authors and publishers voluntarily provide free PDF versions of their work, but its essential to be cautious and verify the authenticity of the source before downloading Etc Source Four Assembly Parts Manual User Guide. In conclusion, the internet offers numerous platforms and websites that allow users to download free PDF files legally. Whether its classic literature, research papers, or magazines, there is something for everyone. The platforms mentioned in this article, such as Project Gutenberg, Open Library, Academia.edu, and Issuu, provide access to a vast collection of PDF files. However, users should always be cautious and verify the legality of the source before downloading Etc Source Four Assembly Parts Manual User Guide any PDF files. With these platforms, the world of PDF downloads is just a click away.

FAQs About Etc Source Four Assembly Parts Manual User Guide Books

How do I know which eBook platform is the best for me? Finding the best eBook platform depends on your reading preferences and device compatibility. Research different platforms, read user reviews, and explore their features before making a choice. Are free eBooks of good quality? Yes, many reputable platforms offer high-quality free eBooks, including classics and public domain works. However, make sure to verify the source to ensure the eBook credibility. Can I read eBooks without an eReader? Absolutely! Most eBook platforms offer webbased readers or mobile apps that allow you to read eBooks on your computer, tablet, or smartphone. How do I avoid digital eye strain while reading eBooks? To prevent digital eye strain, take regular breaks, adjust the font size and background color, and ensure proper lighting while reading eBooks. What the advantage of interactive eBooks? Interactive eBooks incorporate multimedia elements, quizzes, and activities, enhancing the reader engagement and providing a more immersive learning experience. Etc Source Four Assembly Parts Manual User Guide is one of the best book in our library for free trial. We provide copy of Etc Source Four Assembly Parts Manual User Guide in digital format, so the resources that you find are reliable. There are also many Ebooks of related with Etc Source Four Assembly Parts Manual User Guide. Where to download Etc Source Four Assembly Parts Manual User Guide online for free? Are you looking for Etc Source Four Assembly Parts Manual User Guide PDF? This is definitely going to save you time and cash in something you should think about. If you trying to find then search around for online. Without a doubt there are numerous these available and many of them have the freedom. However without doubt you receive whatever you purchase. An alternate way to get ideas is always to check another Etc Source Four Assembly Parts Manual User Guide. This method for see exactly what may be included and adopt these ideas to your book. This site will almost certainly help you save time and effort, money and stress. If you are looking for free books then you really should consider finding to assist you try

this. Several of Etc Source Four Assembly Parts Manual User Guide are for sale to free while some are payable. If you are not sure if the books you would like to download work with for usage along with your computer, it is possible to download free trials. The free guides make it easy for someone to free access online library for download books to your device. You can get free download on free trial for lots of books categories. Our library is the biggest of these that have literally hundreds of thousands of different products categories represented. You will also see that there are specific sites catered to different product types or categories, brands or niches related with Etc Source Four Assembly Parts Manual User Guide. So depending on what exactly you are searching, you will be able to choose e books to suit your own need. Need to access completely for Campbell Biology Seventh Edition book? Access Ebook without any digging. And by having access to our ebook online or by storing it on your computer, you have convenient answers with Etc Source Four Assembly Parts Manual User Guide To get started finding Etc Source Four Assembly Parts Manual User Guide, you are right to find our website which has a comprehensive collection of books online. Our library is the biggest of these that have literally hundreds of thousands of different products represented. You will also see that there are specific sites catered to different categories or niches related with Etc Source Four Assembly Parts Manual User Guide So depending on what exactly you are searching, you will be able to choose ebook to suit your own need. Thank you for reading Etc Source Four Assembly Parts Manual User Guide. Maybe you have knowledge that, people have search numerous times for their favorite readings like this Etc Source Four Assembly Parts Manual User Guide, but end up in harmful downloads. Rather than reading a good book with a cup of coffee in the afternoon, instead they juggled with some harmful bugs inside their laptop. Etc Source Four Assembly Parts Manual User Guide is available in our book collection an online access to it is set as public so you can download it instantly. Our digital library spans in multiple locations, allowing you to get the most less latency time to download any of our books like this one. Merely said, Etc Source Four Assembly Parts Manual User Guide is universally compatible with any devices to read.

Find Etc Source Four Assembly Parts Manual User Guide :

[how to succeed in academics](#)

how to profit from real estate investing under the new rules

[how to organize effective conferences & meetings](#)

how to pay lots less for life insurance

how to pass your driving test

~~how to prepare managerial communications~~

~~how to start operate a small business teacher resource guide~~

~~how to start a home-based photography business~~

how to make money with corn options using grandmills option tables

how to restore antiques

how to make more money at interior design

how to make money in commercial land

how to solve problems for success in freshman physics engineering and beyond

how to run a successful restaurant

how to study literature in english

Etc Source Four Assembly Parts Manual User Guide :

your oxbridge voucher r400 home oxbridge academy liululu - Mar 31 2022

web we disburse for your oxbridge voucher r400 home oxbridge academy and numerous books collections from fictions to scientific investigationh in any way your oxbridge voucher r400 home oxbridge academy is available in our

your oxbridge voucher r400 home oxbridge academy pdf - Aug 16 2023

web your oxbridge voucher r400 home oxbridge academy pdf introduction your oxbridge voucher r400 home oxbridge academy pdf pdf in celebration karen hearn 1998 five centuries of private collecting are represented in this publication of some of the finest art treasures preserved in britain s historic houses

your oxbridge voucher r400 home oxbridge academy copy - Jul 03 2022

web 2 2 your oxbridge voucher r400 home oxbridge academy 2021 01 20 africa s future africa s challenge polity with this book theologian and political observer allan boesak once again displays the strengths of his writings that were evident in the seventies and

your oxbridge voucher r400 home oxbridge academy - Jun 14 2023

web 4 your oxbridge voucher r400 home oxbridge academy 2020 06 30 and the importance of fathers in children s lives the book also addresses policy development and ecd implementation issues presents the ecd programming experience in several countries highlighting best practices and challenges and evaluates the impact of ecd

your oxbridge voucher r400 home oxbridge academy - Oct 06 2022

web jun 7 2023 the your oxbridge voucher r400 home oxbridge academy it is entirely simple then currently we extend the associate to buy and create bargains to acquire and deploy your oxbridge voucher r400 home oxbridge academy therefore plain

youroxbridgevoucherr400homeoxbridgeacademy pdf - Jan 29 2022

web youroxbridgevoucherr400homeoxbridgeacademy 1 2 downloaded from pim isanico com on by guest

youroxbridgevoucherr400homeoxbridgeacademy eventually you will totally

[your oxbridge voucher r400 home oxbridge academy](#) - Dec 08 2022

web your oxbridge voucher r400 home oxbridge academy remaking modernity jan 09 2021 diva sociology collection

reviewing the state of historical study in a wide range of areas while showcasing the use of poststructuralist approaches

your oxbridge voucher r400 home oxbridge academy pdf - Jan 09 2023

web 3 web your oxbridge voucher r400 home oxbridge academy remaking modernity jan 09 2021 diva sociology collection

reviewing the state of historical study in a wide

program costs tuition payments oxbridge academic programs - Dec 28 2021

web jul 27 2023 grades 9 12 july 5 august 1 2023 8 995 oxbridge in new york grades 9 12 june 26 july 23 2023 10 075 all

prices listed across our site are in u s dollars applications are accepted on a rolling basis so we recommend applying as early

as possible to secure a place in your preferred session

[your oxbridge voucher r400 home oxbridge academy pdf](#) - Apr 12 2023

web 2 your oxbridge voucher r400 home oxbridge academy 2023 07 16 displays the strengths of his writings that were

evident in the seventies and eighties bringing christian theology to bear on the political and socio economic realities of our

world a serious and open hearted commentary on the african renaissance and the spirituality of politics

your oxbridge voucher r400 home oxbridge academy pdf - Feb 10 2023

web your oxbridge voucher r400 home oxbridge academy 1 your oxbridge voucher r400 home oxbridge academy thank you

enormously much for downloading your oxbridge voucher

your oxbridge voucher r400 home oxbridge academy - Jun 02 2022

web jun 6 2023 your oxbridge voucher r400 home oxbridge academy duyenhai edu com author gerwald ritter duyenhai edu

com subject your oxbridge voucher r400 home oxbridge academy duyenhai edu com keywords club 60 edgars club edgars

club brings you education offers with oxbridge academy created date

[your oxbridge voucher r400 home oxbridge academy pdf](#) - Jul 15 2023

web mar 29 2023 your oxbridge voucher r400 home oxbridge academy 1 9 downloaded from uniport edu ng on march 29

2023 by guest your oxbridge voucher r400 home oxbridge your oxbridge voucher r400 home oxbridge academy that you are

looking for it will agreed squander the time however below past you visit this web page it will

[your oxbridge voucher r400 home oxbridge academy](#) - Mar 11 2023

web your oxbridge voucher r400 home oxbridge academy as recognized adventure as with ease as experience virtually lesson

amusement as capably as union can be gotten by just checking out a books your oxbridge voucher r400 home oxbridge

academy then it is not directly done you could give a positive response even more on the order of this life

[your oxbridge voucher r400 home oxbridge academy](#) - May 13 2023

web your oxbridge voucher r400 home oxbridge academy benefit partner special offer for club 60 europcar vip only get an additional 5 off your current saving of 10 that s 15 off your europcar rental edgars club members save on all courses at oxbridge academy you ll be happy to know that you can register at any time of the year no more having to

your oxbridge voucher r400 home oxbridge academy 2022 - May 01 2022

web your oxbridge voucher r400 home oxbridge academy study and master accounting grade 11 teacher s guide elite transition revised and expanded edition diversities old and new principles of cost accounting xhosa pearls economic development africa s future africa s challenge study and master accounting grade 12 caps learner s book

[your oxbridge voucher r400 home oxbridge academy 2022](#) - Sep 05 2022

web your oxbridge voucher r400 home oxbridge academy 5 5 fields of research such as humanitarian action medical and information and communication technology disaster risk reduction technologies habitat and sustainable access to energy the authors discuss how innovative technologies such as unmanned aerial vehicles for disaster risk reduction

your oxbridge voucher r400 home oxbridge academy - Aug 04 2022

web apr 8 2023 right here we have countless ebook your oxbridge voucher r400 home oxbridge academy and collections to check out we additionally have the funds for variant types and plus type of the books to browse the within acceptable limits book fiction history novel scientific research as capably as various supplementary sorts of books

[oxbridge oxbridge academy](#) - Feb 27 2022

web how it works oxbridge academy will help you search for suitable specialised tutors book and manage your lessons and keep in touch with your tutors level search and compare tutors please send messages or contact tutors directly book and pay for all of your lessons safely through the website in each of your one to one session

[your oxbridge voucher r400 home oxbridge academy copy](#) - Nov 07 2022

web your oxbridge voucher r400 home oxbridge academy this is likewise one of the factors by obtaining the soft documents of this your oxbridge voucher r400 home oxbridge academy by online

traktör modelleri new holland - Feb 16 2023

web traktör fiyatları traktör modelleri ve tarım makineleri türkiye nin en çok tercih edilen traktör markası newholland com tr de

traktoren 2019 tractors broschurenkalender 30 x 6 uniport edu - Jun 08 2022

web jul 27 2023 traktoren 2019 tractors broschurenkalender 30 x 6 1 1 downloaded from uniport edu ng on july 27 2023 by guest traktoren 2019 tractors

traktoren 2019 tractors broschurenkalender 30 x 6 pdf - Nov 13 2022

web apr 3 2023 traktoren 2019 tractors brochurenkalender 30 x 6 2 9 downloaded from uniport edu ng on april 3 2023 by guest value of ender s ability to sympathize with his

traktoren 2019 tractors brochürenkalender 30 x 60 geöffnet - Jul 21 2023

web tractors tractors new holland tractors for sale ebay traktoren tractors 2020 brochürenkalender 28c57e6 traktoren tractors 2019 brochurenkalender tractors

traktoren 2019 tractors brochurenkalender 30 x 6 uniport edu - Sep 11 2022

web apr 27 2023 traktoren 2019 tractors brochurenkalender 30 x 6 1 11 downloaded from uniport edu ng on april 27 2023 by guest traktoren 2019 tractors

traktoren 2019 tractors brochürenkalender 30 x 60 geöffnet - Nov 01 2021

web goldoni products tractors claas ferrari mowers two wheel tractors tractors traktoren 2019 tractors brochürenkalender 30 x 60 category tractors beamng drive mods

tümosan 2019 traktör fiyat listesi traktörler hakkında herşey - Mar 17 2023

web jan 1 2019 traktorler net bir e posta göndermek ocak 1 2019 son güncelleme ocak 1 2020 0 bir dakikadan az konya ereğli tarım ve hayvancılık festivali 2016 yeni model

traktoren 2019 by - May 07 2022

web traktoren 2019 tractors brochurenkalender 30 x 60 rhaetian railway ge 3 3 claas of america precision agricultural equipment and massey ferguson tractors challenger

traktoren 2019 tractors brochurenkalender 30 x 6 pdf - Jun 20 2023

web traktoren 2019 tractors brochurenkalender 30 x 6 downloaded from poczta builduk org by guest jillian kelley meine drei brüder princeton university

4 traktörün 30 günde sürdüğü tarlayı 8 traktör kaç günde sürer - Feb 04 2022

web apr 17 2017 eodev kullanıcısı b 15 çünkü 4 traktör 30 günde sürüyormus 8 traktörle daha hızlı sürülür 30 2 15 iyi dersler çünkü 4 traktörle 30 günde sürüyo ya 8 traktörle daha

traktoren 2019 posterkalender art image amazon de bücher - May 19 2023

web von kleinen traktoren bis hin zu wahren monstern dieser traktor kalender 2019 bietet allen fans der giganten genau das richtige durch das praktische format von 30 x 30

traktoren tractors 2019 brochürenkalender wandkalender mit - Apr 18 2023

web jun 8 2023 this traktoren tractors 2019 brochürenkalender wandkalender mit herausnehmbarem poster format 30 x 30 cm by dumont kalenderverlag joachim

traktoren 2019 tractors brochurenkalender 30 x 6 pdf full pdf - Jul 09 2022

web jun 30 2023 traktoren 2019 tractors brochurenkalender 30 x 6 pdf yeah reviewing a books traktoren 2019 tractors brochurenkalender 30 x 6 pdf could add your near

traktoren 2019 tractors brochürenkalender 30 x 60 geöffnet - Dec 02 2021

web traktoren 2019 tractors brochürenkalender 30 x 60 geöffnet autokalender fahrzeuge wandplaner by alpha edition hängend 30 x 60 cm 6 sprachiges kalendarium

traktoren 2019 tractors brochurenkalender 30 x 6 uniport edu - Sep 30 2021

web apr 21 2023 traktoren 2019 tractors brochurenkalender 30 x 6 1 12 downloaded from uniport edu ng on april 21 2023 by guest traktoren 2019 tractors

traktoren 2019 tractors brochurenkalender 30 x 6 pdf - Oct 12 2022

web traktoren 2019 tractors brochurenkalender 30 x 6 2 9 downloaded from uniport edu ng on may 10 2023 by guest common ultrasound examinations provence christian

traktoren 2019 tractors brochurenkalender 30 x 6 pdf - Jan 15 2023

web traktoren 2019 tractors brochurenkalender 30 x 6 2 2 downloaded from uniport edu ng on august 1 2023 by guest carl warner s food landscapes carl warner 2010 10 01

traktoren 2019 tractors brochürenkalender 30 x 60 geöffnet - Jan 03 2022

web 2827 traktoren 2019 tractors brochürenkalender 30 x 60 massey ferguson tractors kubota tractors prices list in usa with specification 2020 traktoren agrarheute claas of

traktoren 2020 tractors brochurenkalender 30 x 6 pdf - Aug 10 2022

web traktoren 2020 tractors brochurenkalender 30 x 6 3 3 angefangen vom deutz trekker von 1919 über den elfer 4 traktoren 2020 tractors brochurenkalender 30 x 6

traktoren 2019 tractors brochurenkalender 30 x 6 pdf - Apr 06 2022

web this traktoren 2019 tractors brochurenkalender 30 x 6 pdf as one of the most working sellers here will no question be in the midst of the best options to review title traktoren

traktoren 2019 tractors brochürenkalender 30 x 60 geöffnet - Aug 22 2023

web fsc zertifiziert fotomotivgröße 30 x 30 cm format offen hängend 30 x 60 cm 6 sprachiges kalendarium de fr it gb dk nl feiertage de at ch fr it dk nl

tureng traktör türkçe İngilizce sözlük - Mar 05 2022

web traktör römork katarı tractor trailer train i 82 askeri ağır silah olarak zırhlı traktör dragon i İngilizce türkçe online sözlük tureng kelime ve terimleri çevir ve farklı aksanlarda

traktoren 2019 tractors brochurenkalender 30 x 6 carl warner - Dec 14 2022

web traktoren 2019 tractors brochurenkalender 30 x 6 is available in our book collection an online access to it is set as public so you can get it instantly our digital library spans in

volkswagen jetta a5 service manual 2005 2010 bentley - Feb 15 2023

technical features covers jetta models 2005 2010 based on the a5 platform maintenance procedures from oil changes to belt replacement engine and cylinder head service including timing belt replacement removal and installation of motronic gasoline and diesel fuel injection system components including pompe duse pd and common rail diesel

volkswagen jetta a5 service manual 2005 2010 excerpt - Sep 10 2022

aug 4 2018 volkswagen jetta a5 service manual 2005 2010 excerpt august 4 2018 author bentley publishers category fuel injection throttle ignition system propulsion vehicle parts download pdf 712 3kb

volkswagen jetta service manual 2005 2010 a5 tdi gli - Nov 12 2022

description table of contents the 2005 2010 volkswagen jetta service manual by bentley publishers covers the 1 9l 2 0l diesel 2 0l and 2 5l engines for the volkswagen jetta a5 including the tdi gli and sportwagen volkswagen has been in the business of creating high end automobiles since 1937

volkswagen jetta a5 service manual 2005 2010 scribd - May 18 2023

volkswagen jetta a5 service manual 2005 2010 1 9l and 2 0l diesel 2 0l and 2 5l gasoline including tdi gli and sportwagen price 129 95 bentley stock no vj10 publication date 2009 dec 18 isbn 978 0 8376 1616 2 softcover 8 3 8 in x 11 in case quantity 5 1352 pages 2484 technical photos and illustrations including 991 electrical

volkswagen repair manual jetta 2005 2010 bentley publishers - Aug 21 2023

service manual 2005 2006 2007 2008 2009 2010 1 9l and 2 0l diesel 2 0l and 2 5l gasoline including tdi gli and sportwagen by bentley publishers hardcover 8 3 8 in x 11 in 1352 pages 2484 technical photos and illustrations includes 991 electrical wiring diagrams isbn 13 978 0 8376 1616 2 price 189 95 add to cart

pdf volkswagen jetta a5 service manual 2005 2006 2007 - Jul 20 2023

the volkswagen jetta a5 service manual 2005 2010 is a definitive reference source of technical automotive repair and maintenance information for volkswagen jetta models built on the a5 platform service to volkswagen owners is of top priority to volkswagen and has always included the continuing development and introduction of new and expanded ser

volkswagen jetta service manual 2005 2006 google books - Aug 09 2022

the volkswagen jetta service manual 2005 2006 covers the late 2005 through 2006 model year jetta built on the volkswagen a5 platform bentley repair manuals provide the highest

volkswagen online technical library tech confluence - Mar 04 2022

jun 1 2020 volkswagen jetta golf gti service manual 1999 2005 volkswagen jetta a5 service manual 2005 2010 volkswagen

vanagon t3 official factory repair manual 1980 1991

volkswagen jetta a5 service manual 2005 2010 index - Sep 22 2023

volkswagen jetta a5 service manual 2005 2010 index free download as pdf file pdf text file txt or read online for free complete index from the volkswagen jetta a5 service manual 2005 2010 for more information visit bentleypublishers.com/gallery.htm code vj10

[volkswagen jetta a5 service manual 2005 2010 1 9l 2 0l](#) - Dec 13 2022

volkswagen jetta a5 service manual 2005 2010 1 9l 2 0l diesel 2 0l 2 5l gasoline including tdi gli and sportwagen amazon.co.uk robert bentley 9780837616162 books reference transport automotive buy new 205 85 2 80 delivery 4 8 august details select delivery location only 1 left in stock buy now payment

volkswagen jetta a5 service manual 2005 2006 2007 2008 - Jul 08 2022

the volkswagen jetta a5 service manual 2005 2010 is a definitive reference source of technical automotive repair and maintenance information for volkswagen jetta models built on the a5 platform

[volkswagen jetta a5 service manual 2005 2010 vj10](#) - May 06 2022

this page was in the background for too long and may not have fully loaded try to refresh the page

maintenance schedule 2005 jetta online technical library - Feb 03 2022

may 18 2011 before performing any work please read cautions and warnings before proceeding with any work on your vehicle related technical manuals maintenance schedule 2005 jetta product page jetta 2005 2010 bentleypublishers.com/vw-jetta-2005-2010

volkswagen jetta a5 service manual 2005 2010 index - Jun 19 2023

overview download view volkswagen jetta a5 service manual 2005 2010 index as pdf for free more details words 3 436 pages 9 preview full text volkswagen jetta a5 service manual 2005 2010 index vylygjr3qelm

volkswagen repair manual jetta 2005 2010 bentley publishers - Oct 11 2022

home volkswagen repair volkswagen jetta 2005 2010 back cover about the author printable info sheet volkswagen jetta a5 repair manual photo gallery volkswagen jetta a5 repair manual page spread from product familiarization section browse prev volkswagen next comment on this page contact us customer service tech library

volkswagen jetta service manual 2005 2006 2007 2008 2009 2010 - Apr 17 2023

the volkswagen jetta a5 service manual 2005 2010 is a definitive reference source of technical automotive repair and maintenance information for volkswagen jetta models built on

[volkswagen jetta a5 service manual 2005 2006 2007](#) - Jan 14 2023

jan 1 2009 buy on amazon rate this book volkswagen jetta a5 service manual 2005 2006 2007 2008 2009 2010 bentley

publishers 3 86 14 ratings0 reviews the volkswagen jetta a5 service 2005 2010 is a definitive reference source of technical automotive repair and maintenance information for volkswagen jetta models built on the a5 platform

22016927 volkswagen jetta a5 service manual 2005 2010 index - Apr 05 2022

may 28 2017 technical features covers jetta models 2005 2010 based on the a5 platform maintenance procedures from oil changes to belt replacement engine and cylinder head service including timing belt replacement

volkswagen jetta a5 service manual 2005 2010 xxxvj10 - Jun 07 2022

description the volkswagen jetta a5 service manual 2005 2010 is a definitive reference source of technical automotive repair and maintenance information for volkswagen jetta models built on the a5 platform

volkswagen jetta a5 service manual 2005 2006 2007 2008 2009 2010 - Mar 16 2023

dec 18 2009 the volkswagen jetta a5 service manual 2005 2010 is a definitive reference source of technical automotive repair and maintenance information for volkswagen jetta models built on the a5 platform