

3-XA10-011-B

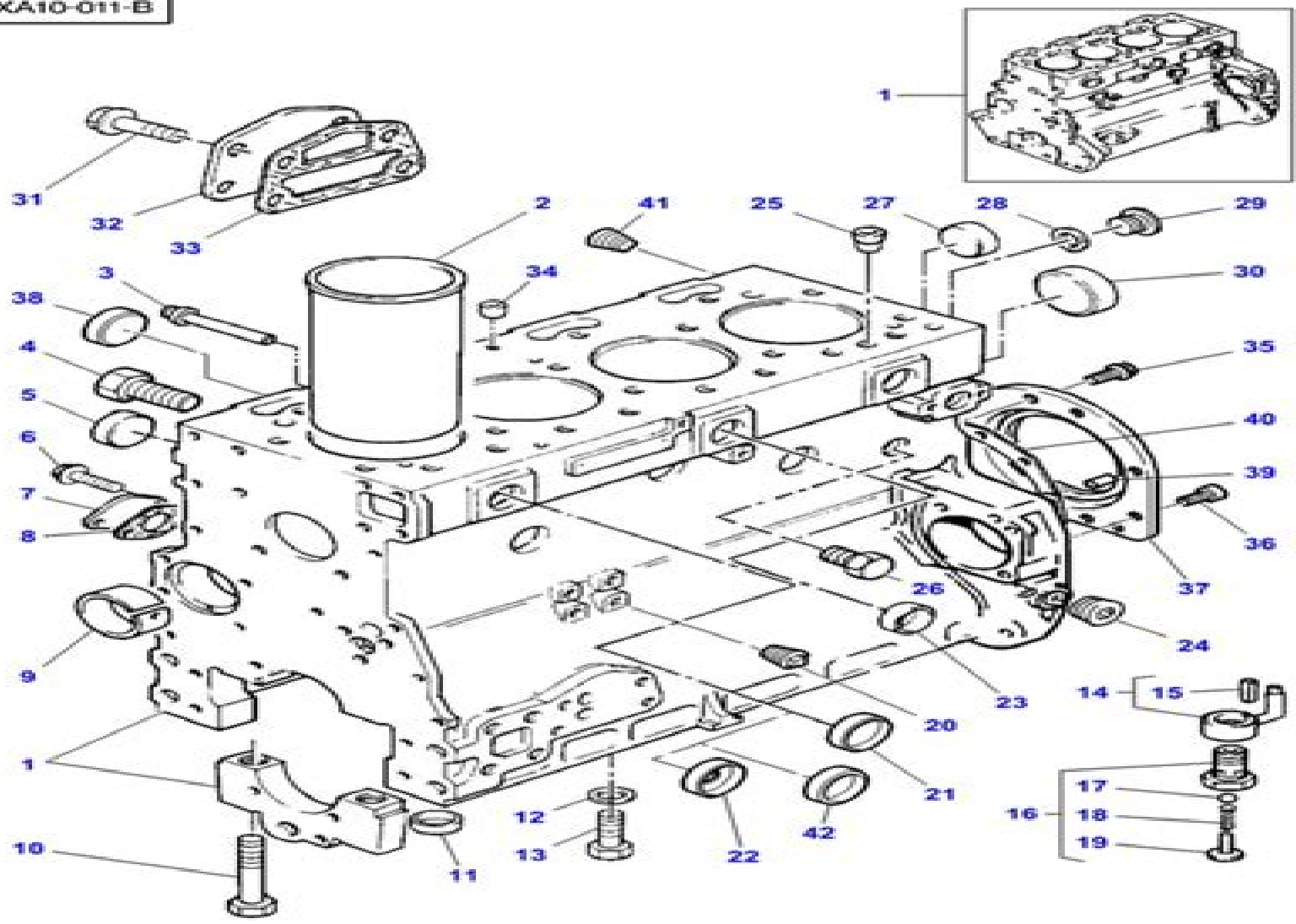

Mf 4345 Manual

CO Houle



Mf 4345 Manual:

Perpetual Trouble Shooter's Manual John Francis Rider,1936 **Manual** Alliance of Unitarian and Other Liberal Christian Women,1918 Moody's Manual of Railroads and Corporation Securities ,1916 **Manual of Environmental Microbiology** Christon J. Hurst,Ronald L. Crawford,Jay L. Garland,David A. Lipson,2007-05-14 The most definitive manual of microbes in air water and soil and their impact on human health and welfare Incorporates a summary of the latest methodology used to study the activity and fate of microorganisms in various environments Synthesizes the latest information on the assessment of microbial presence and microbial activity in natural and artificial environments Features a section on biotransformation and biodegradation Serves as an indispensable reference for environmental microbiologists microbial ecologists and environmental engineers as well as those interested in human diseases water and wastewater treatment and biotechnology Moody's Manual of Industrial and Miscellaneous Securities ,1922 *Moody's Manual of Railroads and Corporation Securities. Government, State and Municipal Supplement* ,1922 **Moody's Manual of Investments** John Sherman Porter,1928 American government securities 1928 53 in 5 annual vols v 1 Railroad securities 1952 53 Transportation v 2 Industrial securities v 3 Public utility securities v 4 Government securities 1928 54 v 5 Banks insurance companies investment trusts real estate finance and credit companies 1928 54 *Moody's Manual of Investments, American and Foreign* ,1928 **Monthly Catalog of United States Government Publications** ,1999 **Perpetual Trouble Shooter's Manual** John Francis Rider,1935

This is likewise one of the factors by obtaining the soft documents of this **Mf 4345 Manual** by online. You might not require more times to spend to go to the books commencement as with ease as search for them. In some cases, you likewise accomplish not discover the publication Mf 4345 Manual that you are looking for. It will unconditionally squander the time.

However below, similar to you visit this web page, it will be suitably enormously easy to get as skillfully as download guide Mf 4345 Manual

It will not understand many grow old as we run by before. You can attain it even if sham something else at home and even in your workplace. hence easy! So, are you question? Just exercise just what we pay for below as capably as evaluation **Mf 4345 Manual** what you like to read!

<https://staging.conocer.cide.edu/results/publication/default.aspx/modeling%20chemistry%20unit%207%20ws3%20answers.pdf>

Table of Contents Mf 4345 Manual

1. Understanding the eBook Mf 4345 Manual
 - The Rise of Digital Reading Mf 4345 Manual
 - Advantages of eBooks Over Traditional Books
2. Identifying Mf 4345 Manual
 - Exploring Different Genres
 - Considering Fiction vs. Non-Fiction
 - Determining Your Reading Goals
3. Choosing the Right eBook Platform
 - Popular eBook Platforms
 - Features to Look for in an Mf 4345 Manual
 - User-Friendly Interface
4. Exploring eBook Recommendations from Mf 4345 Manual

- Personalized Recommendations
 - Mf 4345 Manual User Reviews and Ratings
 - Mf 4345 Manual and Bestseller Lists
5. Accessing Mf 4345 Manual Free and Paid eBooks
 - Mf 4345 Manual Public Domain eBooks
 - Mf 4345 Manual eBook Subscription Services
 - Mf 4345 Manual Budget-Friendly Options
 6. Navigating Mf 4345 Manual eBook Formats
 - ePub, PDF, MOBI, and More
 - Mf 4345 Manual Compatibility with Devices
 - Mf 4345 Manual Enhanced eBook Features
 7. Enhancing Your Reading Experience
 - Adjustable Fonts and Text Sizes of Mf 4345 Manual
 - Highlighting and Note-Taking Mf 4345 Manual
 - Interactive Elements Mf 4345 Manual
 8. Staying Engaged with Mf 4345 Manual
 - Joining Online Reading Communities
 - Participating in Virtual Book Clubs
 - Following Authors and Publishers Mf 4345 Manual
 9. Balancing eBooks and Physical Books Mf 4345 Manual
 - Benefits of a Digital Library
 - Creating a Diverse Reading Collection Mf 4345 Manual
 10. Overcoming Reading Challenges
 - Dealing with Digital Eye Strain
 - Minimizing Distractions
 - Managing Screen Time
 11. Cultivating a Reading Routine Mf 4345 Manual
 - Setting Reading Goals Mf 4345 Manual
 - Carving Out Dedicated Reading Time
 12. Sourcing Reliable Information of Mf 4345 Manual

- Fact-Checking eBook Content of Mf 4345 Manual
 - Distinguishing Credible Sources
13. Promoting Lifelong Learning
 - Utilizing eBooks for Skill Development
 - Exploring Educational eBooks
 14. Embracing eBook Trends
 - Integration of Multimedia Elements
 - Interactive and Gamified eBooks

Mf 4345 Manual Introduction

In this digital age, the convenience of accessing information at our fingertips has become a necessity. Whether its research papers, eBooks, or user manuals, PDF files have become the preferred format for sharing and reading documents. However, the cost associated with purchasing PDF files can sometimes be a barrier for many individuals and organizations. Thankfully, there are numerous websites and platforms that allow users to download free PDF files legally. In this article, we will explore some of the best platforms to download free PDFs. One of the most popular platforms to download free PDF files is Project Gutenberg. This online library offers over 60,000 free eBooks that are in the public domain. From classic literature to historical documents, Project Gutenberg provides a wide range of PDF files that can be downloaded and enjoyed on various devices. The website is user-friendly and allows users to search for specific titles or browse through different categories. Another reliable platform for downloading Mf 4345 Manual free PDF files is Open Library. With its vast collection of over 1 million eBooks, Open Library has something for every reader. The website offers a seamless experience by providing options to borrow or download PDF files. Users simply need to create a free account to access this treasure trove of knowledge. Open Library also allows users to contribute by uploading and sharing their own PDF files, making it a collaborative platform for book enthusiasts. For those interested in academic resources, there are websites dedicated to providing free PDFs of research papers and scientific articles. One such website is Academia.edu, which allows researchers and scholars to share their work with a global audience. Users can download PDF files of research papers, theses, and dissertations covering a wide range of subjects. Academia.edu also provides a platform for discussions and networking within the academic community. When it comes to downloading Mf 4345 Manual free PDF files of magazines, brochures, and catalogs, Issuu is a popular choice. This digital publishing platform hosts a vast collection of publications from around the world. Users can search for specific titles or explore various categories and genres. Issuu offers a seamless reading experience with its user-friendly interface and allows users to download PDF files for offline reading. Apart from dedicated platforms, search engines

also play a crucial role in finding free PDF files. Google, for instance, has an advanced search feature that allows users to filter results by file type. By specifying the file type as "PDF," users can find websites that offer free PDF downloads on a specific topic. While downloading Mf 4345 Manual free PDF files is convenient, it's important to note that copyright laws must be respected. Always ensure that the PDF files you download are legally available for free. Many authors and publishers voluntarily provide free PDF versions of their work, but it's essential to be cautious and verify the authenticity of the source before downloading Mf 4345 Manual. In conclusion, the internet offers numerous platforms and websites that allow users to download free PDF files legally. Whether it's classic literature, research papers, or magazines, there is something for everyone. The platforms mentioned in this article, such as Project Gutenberg, Open Library, Academia.edu, and Issuu, provide access to a vast collection of PDF files. However, users should always be cautious and verify the legality of the source before downloading Mf 4345 Manual any PDF files. With these platforms, the world of PDF downloads is just a click away.

FAQs About Mf 4345 Manual Books

1. Where can I buy Mf 4345 Manual books? Bookstores: Physical bookstores like Barnes & Noble, Waterstones, and independent local stores. Online Retailers: Amazon, Book Depository, and various online bookstores offer a wide range of books in physical and digital formats.
2. What are the different book formats available? Hardcover: Sturdy and durable, usually more expensive. Paperback: Cheaper, lighter, and more portable than hardcovers. E-books: Digital books available for e-readers like Kindle or software like Apple Books, Kindle, and Google Play Books.
3. How do I choose a Mf 4345 Manual book to read? Genres: Consider the genre you enjoy (fiction, non-fiction, mystery, sci-fi, etc.). Recommendations: Ask friends, join book clubs, or explore online reviews and recommendations. Author: If you like a particular author, you might enjoy more of their work.
4. How do I take care of Mf 4345 Manual books? Storage: Keep them away from direct sunlight and in a dry environment. Handling: Avoid folding pages, use bookmarks, and handle them with clean hands. Cleaning: Gently dust the covers and pages occasionally.
5. Can I borrow books without buying them? Public Libraries: Local libraries offer a wide range of books for borrowing. Book Swaps: Community book exchanges or online platforms where people exchange books.
6. How can I track my reading progress or manage my book collection? Book Tracking Apps: Goodreads, LibraryThing, and Book Catalogue are popular apps for tracking your reading progress and managing book collections. Spreadsheets:

You can create your own spreadsheet to track books read, ratings, and other details.

7. What are Mf 4345 Manual audiobooks, and where can I find them? Audiobooks: Audio recordings of books, perfect for listening while commuting or multitasking. Platforms: Audible, LibriVox, and Google Play Books offer a wide selection of audiobooks.
8. How do I support authors or the book industry? Buy Books: Purchase books from authors or independent bookstores. Reviews: Leave reviews on platforms like Goodreads or Amazon. Promotion: Share your favorite books on social media or recommend them to friends.
9. Are there book clubs or reading communities I can join? Local Clubs: Check for local book clubs in libraries or community centers. Online Communities: Platforms like Goodreads have virtual book clubs and discussion groups.
10. Can I read Mf 4345 Manual books for free? Public Domain Books: Many classic books are available for free as they're in the public domain. Free E-books: Some websites offer free e-books legally, like Project Gutenberg or Open Library.

Find Mf 4345 Manual :

[modeling chemistry unit 7 ws3 answers](#)

modern biology study guide and review amphibians

~~modern biology section review answers leaves~~

mng26exam papers 2013

mk1 golf blower switch wiring

mk4 golf gti workshop manual

mockingjay reading for comprehension

[modern auditing and assurance services 5e study guide](#)

modeling workshop 2002 unit iii lab

[mmath1 hp3 eng tz0 se m](#)

~~modern biology section 14 3 answer key~~

[mk5 golf gti owners manual](#)

~~mk6 jetta tdi service manual~~

model 220 ac pegnet llc husqvarna automower

modeling with functions precalculus tesccc

Mf 4345 Manual :

CARRIAGE CAMEO OWNER'S MANUAL Pdf Download View and Download Carriage Cameo owner's manual online. Cameo motorhomes pdf manual download ... Important Fifth Wheel Slide out Operating Instructions · Coach. Carriage Cameo Owner's Manual Carriage Cameo Pdf User Manuals. View online or download Carriage Cameo Owner's Manual. ... Important Fifth Wheel Slide out Operating Instructions. 45. Coach. 46. OWNER MANUALS, BROCHURES, & DOC'S DOWNLOADS CARRIAGE FACTORY TECHNICIAN REPAIR MANUALS. Files are in PDF format. Over 300 Repair & Maintenance Documents and Schematics, plus (If available) Carriage Inc. CAMEO by Carriage 5th Wheel Travel Trailer RV Manual CAMEO by Carriage 5th Wheel Travel Trailer RV Manual - 350 pages with Camper Appliance Service Operation & Repair. wrenchmasters. Carriage owners manual - Good Sam Community - 2023621 Nov 26, 2023 — Anyone know where I can get a 1998 Carriage Conestoga owners manual ? - 2023621. I need an owners manual and a wiring diagram for a 2010 Oct 14, 2021 — I need an owners manual and a wiring diagram for a 2010 Carriage cameo 37sk3 fifth wheel - Answered by a verified RV Mechanic. CAMEO by Carriage Trailer 5th Wheel Operations Manual ... CAMEO by Carriage Trailer 5th Wheel Operations Manual RV 350pg w/ Camper Service ; Item Number. 134655229167 ; Accurate description. 4.8 ; Reasonable shipping cost. 2001 Carriage Cameo LXI F35KS3 Aug 19, 2018 — We purchased a used Carriage Cameo F35KS3. I am trying to find some manuals on the fifth wheel so we can understand what some of the things ... AVAILABLE CARRIAGE-LIFESTYLE DOCUMENTS & FILES ... This is a list of the Amenities of the Owners Club & Forum and Documents & Files related to Carriage & Lifestyle 5th Wheel RV's . The Docs & files are ... Owner Manuals OWNER'S MANUALS · Click To Download Manuals · Most Recent Owner's Manual · Owner's Manuals Archive. 2014 Owners Manual · 2015 Carriage 2 Year Owners Manual ... Auditing Cases Section 9 Solution (PDF) Auditing Cases Section 9. Solution. This is likewise one of the factors by obtaining the soft documents of this Auditing Cases Section 9 Solution by online. Reading free Auditing cases section 9 solution (PDF) Jun 14, 2023 — Right here, we have countless books auditing cases section 9 solution and collections to check out. We additionally provide variant types ... Chapter 9.6 Solutions | Auditing Cases 6th Edition Access Auditing Cases 6th Edition Chapter 9.6 solutions now. Our solutions are written by Chegg experts so you can be assured of the highest quality! Auditing cases section 9 solution (Download Only) May 25, 2023 — Eventually, auditing cases section 9 solution will categorically discover a extra experience and finishing by spending more cash. yet. Auditing Cases 6th Edition - Problem 3RB from Chapter 9.6... The audit policy of Audit firm requires that direct testing would be followed where individual item in a particular account have misstatement greater than the ... ACC4410 - Integrated Audit Practice Case #9 - ... View Integrated Audit Practice Case #9 - Recommended Solution.pdf from ACC 4410 at Aurora University ... 22-18Summary of misstatementssection is complete and ... Chapter 9 Solutions In this case the auditor plans an audit approach that combines control reliance and substantive testing. or; Control risk may be assessed low, but audit ... Solution Manual Auditing and

Assurance Services 13e by ... Chapter 9. Materiality and Risk. Review Questions. 9-1 The parts of planning are: accept client and perform initial planning, understand the client's ... Cloud 9 An Audit Case Study canadian 1st Edition ... Sep 13, 2019 — Full download :

<https://alibabadownload.com/product/cloud-9-an-audit-case-study-canadian-1st-edition-campbell-solutions-manual/> Cloud 9 An Audit Section 9. Organizing Audits of Consumer Services Learn what an audit of consumer services is, what it can do, why, when, and by whom it might be conducted, and how to organize one if necessary. Kenmore Service Manual | Get the Immediate PDF ... Kenmore Service Manual for ANY Kenmore model. We offer PDF and Booklet service and repair manuals for all brands and models. Download Support Manuals Download Use & Care Guides. All the information you need to operate and maintain your Kenmore Floorcare product—downloadable for your convenience. To find the ... I am looking for a service manual for a Kenmore Elite Aug 16, 2022 — I am looking for a service manual for a Kenmore Elite 795.74025.411.

Contractor's Assistant: Do you know the model of your Kenmore ... Kenmore 158.1781 158.1782 Service Manual Kenmore 158.1781 158.1782 service and repair manual. 18 pages. PDF download We also have a printing service. The printed and bound manual is available with ... Kenmore Elite 66513633100 trash compactor manual Download the manual for model Kenmore Elite 66513633100 trash compactor. Sears Parts Direct has parts, manuals & part diagrams for all types of repair ... I am trying to locate a service manual for the Kalmar AC Aug 18, 2022 — I am trying to locate a service manual for the Kalmar AC ET30 EV PNF. Are you able to help me? Serial number 009763A. I - Answered by a ... Kenmore Air: Land & Seaplane Flights | Tours & Charters Kenmore Air flies from Seattle to destinations throughout the San Juan Islands, Victoria & BC. Book flights, scenic tours and charters. Does anyone have a digital copy of the Singer Service ... Does anyone have a digital copy of the Singer Service Manual for a model 237? ... Does anyone know how to find the owners manual for a Kenmore ... Stryker Transport 5050 Stretcher chair Service Manual | PDF Home; All Categories; General · Beds/Stretchers/Mattresses · Stretcher · Stryker - Transport · Documents; 5050 Stretcher chair Service Manual ...