

DIAGNOSTIC MANUAL

MaxxForce[®] 11 and 13 Engine

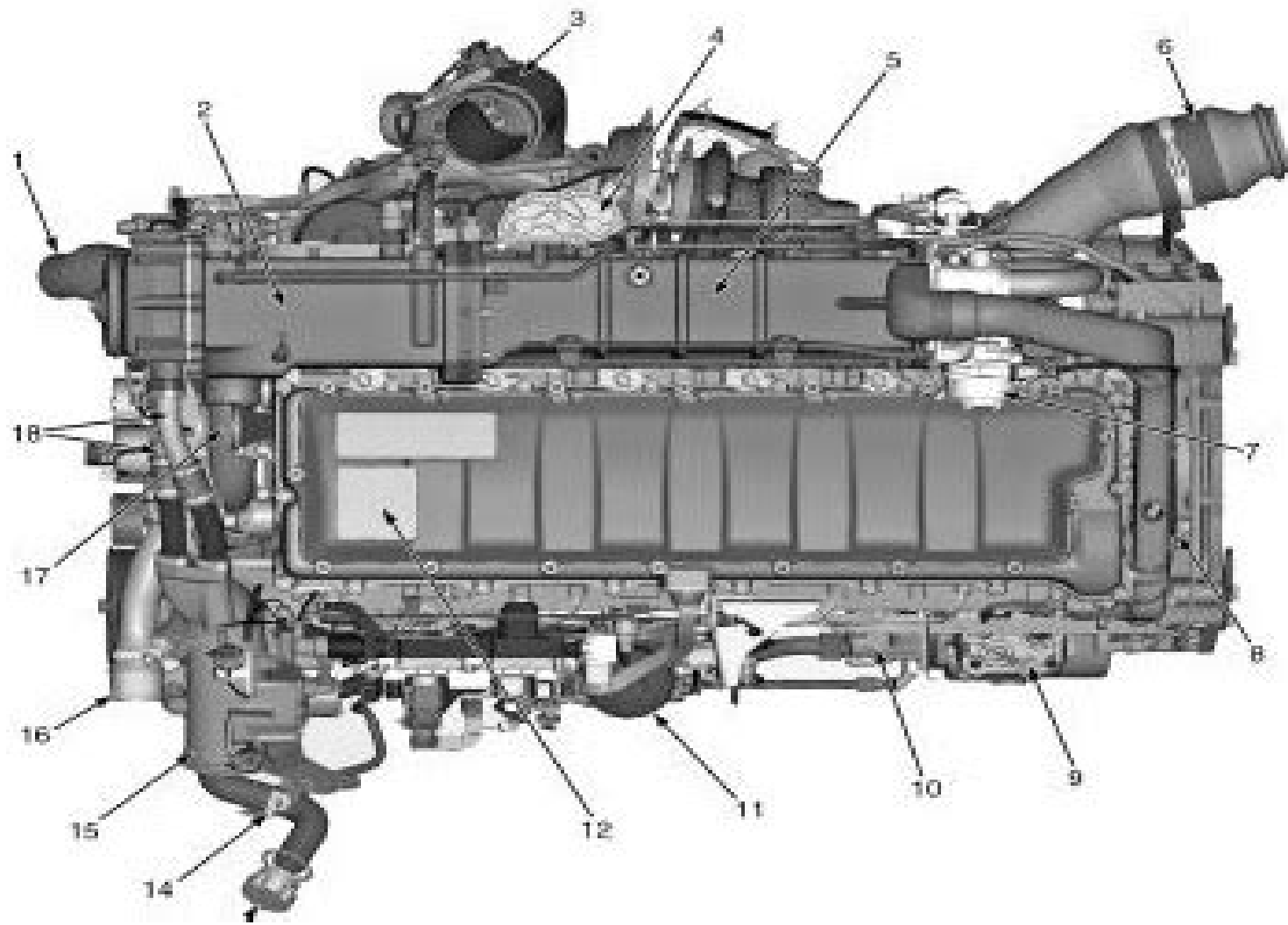

Maxxforce 13 Service Manual

Karin Nielsen-Saines



Maxxforce 13 Service Manual:

Service Manual ,2008 **Service Manual, Model J13, J15 & J16 Series Engines** ,1979 **Volvo S40 & V50 Petrol & Diesel (Mar 04 -03) 04 to 13** Mark Storey,2019-03-07 *Series 53 Service Manual* Detroit Diesel Corporation,1990 [Service Manual](#) ,1985 **Ford C-Max Petrol and Diesel (03-10) 53 to 10** M. R. Storey,2011-02-01 MPV inc special limited editions Does NOT cover CVT or Powershift transmissions Petrol 1 6 litre 1596cc 1 8 litre 1798cc 2 0 litre 1998cc Diesel 1 6 litre 1560cc 1 8 litre 1753cc 2 0 litre 1998cc *MG Service Manual* ,1952 [Gas](#) ,1983 **BMW F800 (F650, F700) Twins** Editors of Haynes Manuals,2016-11-15 Complete coverage of your BMW F650 F700 F800 Twins 06 16 With a Haynes manual you can do it yourself from simple maintenance to basic repairs Haynes writes every book based on a complete teardown of the motorcycle We learn the best ways to do a job and that makes it quicker easier and cheaper for you Our books have clear instructions and hundreds of photographs that show each step Whether you re a beginner or a pro you can save big with Haynes Step by step procedures Easy to follow photos Complete troubleshooting section Valuable short cuts Color spark plug diagnosis What s covered F800S 798cc 06 10 F800ST 798cc 06 12 F800GT 798cc 13 16 F800GS 798cc 08 16 F800GS Adv 798cc 13 16 F800R 798cc 09 16 F650GS 798cc 08 12 F700GS 798cc 12 16 [Ford Aerostar Mini-vans Automotive Repair Manual](#) Larry Warren,Mark Christman,John Harold Haynes,1996 Offers step by step procedures linked to hundreds of easy to follow photos quick and easy troubleshooting sections detailed wiring diagram and color spark plug diagnosis Every manual based on a complete teardown and rebuild **Ford S Max & Galaxy Diesel Owners Workshop Manual** Anon,2016-04-28 **V-71 Service Manual** Detroit Diesel Corporation,1989 **Service Manual, V-8 Engine M116.96 (3.8) & M117.96 (5.0)** Mercedes-Benz of North America,1991 **Volvo 850 Service and Repair Manual** John S. Mead,1996 Saloon Estate inc T5 versions special limited editions Petrol 2 0 litre 1984cc 2 3 litre 2319cc 2 5 litre 2435cc [Maintenance Manual for Models 6-498, 12-498, 8-498, 16-498](#) General Motors Corporation. Cleveland Diesel Engine Division,1960 **Master Repair Manual - Overhead Valve Engines** Ford Motor Company of Canada,19?? *Volvo 400 Series Service and Repair Manual* A. K. Legg,1999 Hatchback Saloon Coupe inc Turbo special limited editions Petrol 1 6 litre 1596cc 1 7 litre 1721cc 1 8 litre 1794cc 2 0 litre 1998cc *Service Manual* ,2022

Motor's Quick Service Manual Ralph Ritchen,Louis C. Forier,Motor (New York, N.Y.),1967 [BMW F650 Singles](#) , '94-'07 Haynes Publishing,2018-05-01 Each Haynes manual provides specific and detailed instructions for performing everything from basic maintenance and troubleshooting to a complete overhaul of the machine in this case the BMW F650 Singles model years 1994 through 2007 Do it yourselfers will find this service and repair manual more comprehensive than the factory manual making it an indispensable part of their tool box A typical Haynes manual covers general information troubleshooting lubrication and routine maintenance engine top end engine lower end primary drive clutch and external shift mechanism transmission and internal shift mechanism engine management system electrical system wheels tires and

drivebelt front suspension and steering rear suspension brakes body and color wiring diagrams An index makes the manual easy to navigate

Unveiling the Power of Verbal Artistry: An Mental Sojourn through **Maxxforce 13 Service Manual**

In a global inundated with displays and the cacophony of fast transmission, the profound power and emotional resonance of verbal art frequently disappear in to obscurity, eclipsed by the constant assault of sound and distractions. Yet, located within the musical pages of **Maxxforce 13 Service Manual**, a charming perform of fictional elegance that pulses with raw emotions, lies an wonderful trip waiting to be embarked upon. Published by way of a virtuoso wordsmith, that enchanting opus instructions viewers on a psychological odyssey, softly revealing the latent possible and profound influence stuck within the delicate web of language. Within the heart-wrenching expanse of the evocative analysis, we can embark upon an introspective exploration of the book is main themes, dissect their interesting writing design, and immerse ourselves in the indelible impact it leaves upon the depths of readers souls.

https://staging.conocer.cide.edu/About/publication/Download_PDFS/manual_service_citroen_berlingo.pdf

Table of Contents Maxxforce 13 Service Manual

1. Understanding the eBook Maxxforce 13 Service Manual
 - The Rise of Digital Reading Maxxforce 13 Service Manual
 - Advantages of eBooks Over Traditional Books
2. Identifying Maxxforce 13 Service Manual
 - Exploring Different Genres
 - Considering Fiction vs. Non-Fiction
 - Determining Your Reading Goals
3. Choosing the Right eBook Platform
 - Popular eBook Platforms
 - Features to Look for in an Maxxforce 13 Service Manual
 - User-Friendly Interface
4. Exploring eBook Recommendations from Maxxforce 13 Service Manual
 - Personalized Recommendations

- Maxxforce 13 Service Manual User Reviews and Ratings
- Maxxforce 13 Service Manual and Bestseller Lists
- 5. Accessing Maxxforce 13 Service Manual Free and Paid eBooks
 - Maxxforce 13 Service Manual Public Domain eBooks
 - Maxxforce 13 Service Manual eBook Subscription Services
 - Maxxforce 13 Service Manual Budget-Friendly Options
- 6. Navigating Maxxforce 13 Service Manual eBook Formats
 - ePub, PDF, MOBI, and More
 - Maxxforce 13 Service Manual Compatibility with Devices
 - Maxxforce 13 Service Manual Enhanced eBook Features
- 7. Enhancing Your Reading Experience
 - Adjustable Fonts and Text Sizes of Maxxforce 13 Service Manual
 - Highlighting and Note-Taking Maxxforce 13 Service Manual
 - Interactive Elements Maxxforce 13 Service Manual
- 8. Staying Engaged with Maxxforce 13 Service Manual
 - Joining Online Reading Communities
 - Participating in Virtual Book Clubs
 - Following Authors and Publishers Maxxforce 13 Service Manual
- 9. Balancing eBooks and Physical Books Maxxforce 13 Service Manual
 - Benefits of a Digital Library
 - Creating a Diverse Reading Collection Maxxforce 13 Service Manual
- 10. Overcoming Reading Challenges
 - Dealing with Digital Eye Strain
 - Minimizing Distractions
 - Managing Screen Time
- 11. Cultivating a Reading Routine Maxxforce 13 Service Manual
 - Setting Reading Goals Maxxforce 13 Service Manual
 - Carving Out Dedicated Reading Time
- 12. Sourcing Reliable Information of Maxxforce 13 Service Manual
 - Fact-Checking eBook Content of Maxxforce 13 Service Manual

- Distinguishing Credible Sources
- 13. Promoting Lifelong Learning
 - Utilizing eBooks for Skill Development
 - Exploring Educational eBooks
- 14. Embracing eBook Trends
 - Integration of Multimedia Elements
 - Interactive and Gamified eBooks

Maxxforce 13 Service Manual Introduction

Maxxforce 13 Service Manual Offers over 60,000 free eBooks, including many classics that are in the public domain. Open Library: Provides access to over 1 million free eBooks, including classic literature and contemporary works. Maxxforce 13 Service Manual Offers a vast collection of books, some of which are available for free as PDF downloads, particularly older books in the public domain. Maxxforce 13 Service Manual : This website hosts a vast collection of scientific articles, books, and textbooks. While it operates in a legal gray area due to copyright issues, its a popular resource for finding various publications. Internet Archive for Maxxforce 13 Service Manual : Has an extensive collection of digital content, including books, articles, videos, and more. It has a massive library of free downloadable books. Free-eBooks Maxxforce 13 Service Manual Offers a diverse range of free eBooks across various genres. Maxxforce 13 Service Manual Focuses mainly on educational books, textbooks, and business books. It offers free PDF downloads for educational purposes. Maxxforce 13 Service Manual Provides a large selection of free eBooks in different genres, which are available for download in various formats, including PDF. Finding specific Maxxforce 13 Service Manual, especially related to Maxxforce 13 Service Manual, might be challenging as theyre often artistic creations rather than practical blueprints. However, you can explore the following steps to search for or create your own Online Searches: Look for websites, forums, or blogs dedicated to Maxxforce 13 Service Manual, Sometimes enthusiasts share their designs or concepts in PDF format. Books and Magazines Some Maxxforce 13 Service Manual books or magazines might include. Look for these in online stores or libraries. Remember that while Maxxforce 13 Service Manual, sharing copyrighted material without permission is not legal. Always ensure youre either creating your own or obtaining them from legitimate sources that allow sharing and downloading. Library Check if your local library offers eBook lending services. Many libraries have digital catalogs where you can borrow Maxxforce 13 Service Manual eBooks for free, including popular titles. Online Retailers: Websites like Amazon, Google Books, or Apple Books often sell eBooks. Sometimes, authors or publishers offer promotions or free periods for certain books. Authors Website Occasionally, authors provide excerpts or short stories for free on their websites. While this might not be the Maxxforce 13

Service Manual full book , it can give you a taste of the authors writing style.Subscription Services Platforms like Kindle Unlimited or Scribd offer subscription-based access to a wide range of Maxxforce 13 Service Manual eBooks, including some popular titles.

FAQs About Maxxforce 13 Service Manual Books

1. Where can I buy Maxxforce 13 Service Manual books? Bookstores: Physical bookstores like Barnes & Noble, Waterstones, and independent local stores. Online Retailers: Amazon, Book Depository, and various online bookstores offer a wide range of books in physical and digital formats.
2. What are the different book formats available? Hardcover: Sturdy and durable, usually more expensive. Paperback: Cheaper, lighter, and more portable than hardcovers. E-books: Digital books available for e-readers like Kindle or software like Apple Books, Kindle, and Google Play Books.
3. How do I choose a Maxxforce 13 Service Manual book to read? Genres: Consider the genre you enjoy (fiction, non-fiction, mystery, sci-fi, etc.). Recommendations: Ask friends, join book clubs, or explore online reviews and recommendations. Author: If you like a particular author, you might enjoy more of their work.
4. How do I take care of Maxxforce 13 Service Manual books? Storage: Keep them away from direct sunlight and in a dry environment. Handling: Avoid folding pages, use bookmarks, and handle them with clean hands. Cleaning: Gently dust the covers and pages occasionally.
5. Can I borrow books without buying them? Public Libraries: Local libraries offer a wide range of books for borrowing. Book Swaps: Community book exchanges or online platforms where people exchange books.
6. How can I track my reading progress or manage my book collection? Book Tracking Apps: Goodreads, LibraryThing, and Book Catalogue are popular apps for tracking your reading progress and managing book collections. Spreadsheets: You can create your own spreadsheet to track books read, ratings, and other details.
7. What are Maxxforce 13 Service Manual audiobooks, and where can I find them? Audiobooks: Audio recordings of books, perfect for listening while commuting or multitasking. Platforms: Audible, LibriVox, and Google Play Books offer a wide selection of audiobooks.
8. How do I support authors or the book industry? Buy Books: Purchase books from authors or independent bookstores. Reviews: Leave reviews on platforms like Goodreads or Amazon. Promotion: Share your favorite books on social media or recommend them to friends.

9. Are there book clubs or reading communities I can join? Local Clubs: Check for local book clubs in libraries or community centers. Online Communities: Platforms like Goodreads have virtual book clubs and discussion groups.
10. Can I read Maxxforce 13 Service Manual books for free? Public Domain Books: Many classic books are available for free as they're in the public domain. Free E-books: Some websites offer free e-books legally, like Project Gutenberg or Open Library.

Find Maxxforce 13 Service Manual :

manual service citroen berlingo

manual repair renault modus

manual sony xperia tx

manual service nissan cedric y31

manual service on yamaha 660 grizzly

manual sears radial arm saw

~~manual sylvania netbook~~

manual shop equinox 2005

~~manual reparacion motor international dt360~~

manual setting cdi rextor

manual taller daelim daystar 125

~~manual reset alcatel one touch~~

manual sync ford en espanol

manual roland juno d portugues

manual samsung galaxy s3 mini gt i8190

Maxxforce 13 Service Manual :

How to Marry the Rich: Sayles, Ginie Polo In this incredible book, a reader comes to witness the astonishing knowledge of the mesmerizing Ginie Sayles, whose illuminating wisdom makes the brightest ... How to Marry the Rich book by Ginie Sayles Buy a cheap copy of How to Marry the Rich book by Ginie Sayles. A former stockbroker now married to a millionaire reveals her secrets for securing a lasting ... The Rich Will Marry Someone, Why Not You? TM - Ginie ... Now the world's one and only "Marry Rich consultant reveals her secrets in a detailed, step-by-step plan for meeting and marrying money. It's unique,

it's ... ginie sayles's how to marry the rich pdf I read somewhere here about anna bey's plagiarized content from ginie sayles's how to marry the rich. I'd like to ask if any of you ladies ... How can I marry a rich guy? This can be successfully compiled in three simple steps: · Fall in love with a simpleton who loves you back. · Love him unconditionally, nurture him, support ...

How To Marry The Rich - By Ginie Sayles (paperback) Now the world's one and only "Marry Rich consultant reveals her secrets in a detailed, step-by-step plan for meeting and marrying money. It's unique, it's ... "The Rich Will Marry Someone, Why Not You?"™ - Ginie ... Now the world's one and only "Marry Rich consultant reveals her secrets in a detailed, step-by-step plan for meeting and marrying money. It's unique, it's ... 12 Ways to Marry a Millionaire How to Marry a Millionaire · 1 Sign up for a millionaire dating app. · 2 Try your hand at rich-people hobbies. · 3 Hang out at country clubs and fundraisers. · 4 ... How To Marry The Rich - People Like Us episode #3 - YouTube The Ultimate Guide on How to Marry the Rich Who Will ... Buy the book Marrying the Rich for Beginners: The Ultimate Guide on How to Marry the Rich Who Will Cherish, Love, Adore and Grant you All your Heart Desires ... Strategic Planning For Success: Aligning People ... - Wiley Strategic Planning For Success: Aligning People ... - Wiley Strategic Planning For Success: Aligning... by Roger ... Useful, pragmatic, and proven tools and concepts, including needs assessment, needs analysis, and costs-consequences analysis. Strategic Planning for Success ... Strategic Planning For Success: Aligning People ... Strategic Planning for Success will show you how to define, deliver, develop, and promote genuine performance improvement within your organization. --This text ... Strategic planning for success; aligning people TITLE: Strategic planning for success; aligning people, performance, and payoffs. AUTHOR: Kaufman, Roger et al. PUBLISHER: Jossey-Bass ... Strategic Planning for Success Welcome to Strategic Planning for Success: Aligning People, Performance, and Payoffs. This is a practical and pragmatic book with cases-in-point, guides, job. Strategic Planning For Success: Aligning People, ... Strategic Planning for Success offers you a pragmatic guide to the design and development of practical and pragmatic strategic thinking and organizational ... Strategic Planning For Success: Aligning People, Performance ... Strategic Planning for Success offers you a pragmatic guide to the design and development of practical and pragmatic strategic thinking and organizational ... Book Review: Strategic Planning for Success: Aligning ... Roger Kaufman, Hugh Oakley-Browne, Ryan Watkins, and Doug Leigh As I read this book, my first reaction was, although it covered a lot of territory with ... Strategic planning for success - Vanderbilt Libraries Catalog Strategic planning for success : aligning people, performance, and payoffs / Roger Kaufman Strategic planning for success : aligning people, performance ... Strategic Planning for Success: Aligning People ... Mar 6, 2003 — Strategic Planning for Success offers you a pragmatic guide to the design and development of practical and pragmatic strategic thinking and ... E-class Operator's Manual Please abide by the recommendations contained in this manual. They are designed to acquaint you with the operation of your Mercedes-Benz. • Please abide by the ... Mercedes W210 Owner's Manual in PDF! MERCEDES-BENZ Owner's Manuals - view manuals online or download PDF for free! Choose your car: A-class, B-class, C-class, E-class, GLK, GLE, GLB,

EQB, EQC, ... Mercedes Benz W210 6-speed Manual transmission. Engine 1 998 ccm (122 cui), 4-cylinder, In-Line, 16-valves, M111.957. A JE DOMA. 2000 Mercedes Benz W210 320 CDI 3.2 (197 cui). When/where was a manual tranny offered with e320? Dec 18, 2008 — I've a facelift W210 brochure in German and a manual transmission is NOT available with the 320 diesel or the 320 gas engine or any engine ... E320 CDI owners manual Jan 16, 2008 — E320 CDI owners manual ... You may find a PDF copy of the US manual too (different address of course). ... The USA version for 2006 will cover the ... w210 e320 cdi vs 3.2 manual - YouTube Mercedes-Benz E-Class Diesel Workshop Manual 1999 ... This Owners Edition Workshop Manual covers the Mercedes-Benz E Class W210 Series from 1999 to 2006, fitted with the four, five & 6 cylinder Cdi engine. Service & Repair Manuals for Mercedes-Benz E320 Get the best deals on Service & Repair Manuals for Mercedes-Benz E320 when you shop the largest online selection at eBay.com. Free shipping on many items ... how hard is it to manual swap a Mercedes E320? May 6, 2019 — Mechanically, manual swaps are easy on cars that came from the factory (somewhere) as a manual. Problem is the electrical. The E36 had a ... MERCEDES W210 E Class Diesel CDI Workshop Manual ... This Owners Edition Workshop Manual has been specially written for the practical owner who wants to maintain a vehicle in first-class condition and carry ...