

Homelite®

HLT26CD

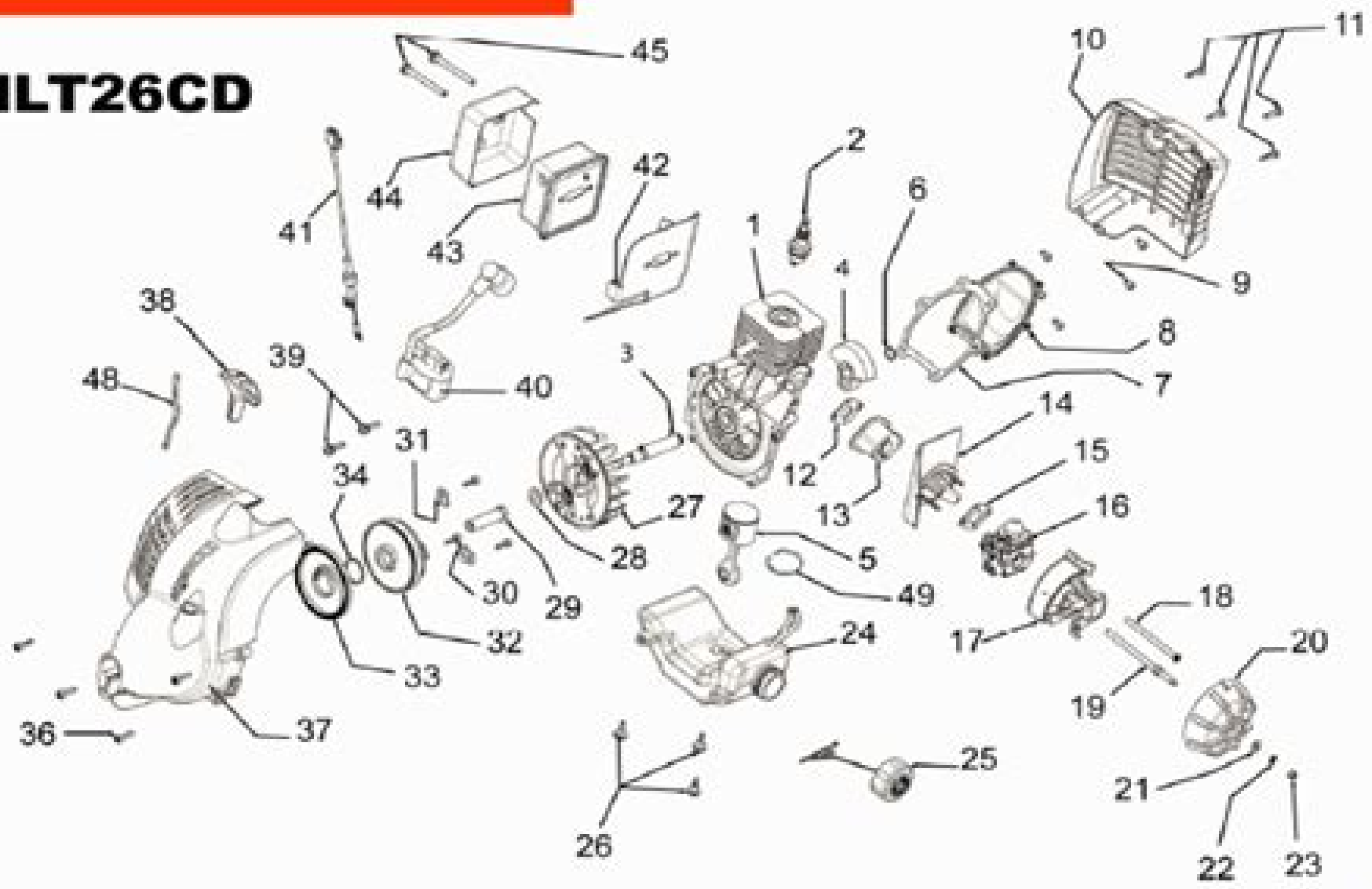

Manual For Hlt26cd Manuel

J Spring



Manual For Hlt26cd Manuel:

This book delves into Manual For Hlt26cd Manuel. Manual For Hlt26cd Manuel is a vital topic that needs to be grasped by everyone, ranging from students and scholars to the general public. The book will furnish comprehensive and in-depth insights into Manual For Hlt26cd Manuel, encompassing both the fundamentals and more intricate discussions.

1. The book is structured into several chapters, namely:
 - Chapter 1: Introduction to Manual For Hlt26cd Manuel
 - Chapter 2: Essential Elements of Manual For Hlt26cd Manuel
 - Chapter 3: Manual For Hlt26cd Manuel in Everyday Life
 - Chapter 4: Manual For Hlt26cd Manuel in Specific Contexts
 - Chapter 5: Conclusion
2. In chapter 1, the author will provide an overview of Manual For Hlt26cd Manuel. This chapter will explore what Manual For Hlt26cd Manuel is, why Manual For Hlt26cd Manuel is vital, and how to effectively learn about Manual For Hlt26cd Manuel.
3. In chapter 2, this book will delve into the foundational concepts of Manual For Hlt26cd Manuel. The second chapter will elucidate the essential principles that must be understood to grasp Manual For Hlt26cd Manuel in its entirety.
4. In chapter 3, this book will examine the practical applications of Manual For Hlt26cd Manuel in daily life. The third chapter will showcase real-world examples of how Manual For Hlt26cd Manuel can be effectively utilized in everyday scenarios.
5. In chapter 4, this book will scrutinize the relevance of Manual For Hlt26cd Manuel in specific contexts. The fourth chapter will explore how Manual For Hlt26cd Manuel is applied in specialized fields, such as education, business, and technology.
6. In chapter 5, this book will draw a conclusion about Manual For Hlt26cd Manuel. This chapter will summarize the key points that have been discussed throughout the book.

This book is crafted in an easy-to-understand language and is complemented by engaging illustrations. This book is highly recommended for anyone seeking to gain a comprehensive understanding of Manual For Hlt26cd Manuel.

https://staging.conocer.cide.edu/data/uploaded-files/fetch.php/Imu_Cet_Question_Paper.pdf

Table of Contents Manual For Hlt26cd Manuel

1. Understanding the eBook Manual For Hlt26cd Manuel

- The Rise of Digital Reading Manual For Hlt26cd Manuel
- Advantages of eBooks Over Traditional Books
- 2. Identifying Manual For Hlt26cd Manuel
 - Exploring Different Genres
 - Considering Fiction vs. Non-Fiction
 - Determining Your Reading Goals
- 3. Choosing the Right eBook Platform
 - Popular eBook Platforms
 - Features to Look for in an Manual For Hlt26cd Manuel
 - User-Friendly Interface
- 4. Exploring eBook Recommendations from Manual For Hlt26cd Manuel
 - Personalized Recommendations
 - Manual For Hlt26cd Manuel User Reviews and Ratings
 - Manual For Hlt26cd Manuel and Bestseller Lists
- 5. Accessing Manual For Hlt26cd Manuel Free and Paid eBooks
 - Manual For Hlt26cd Manuel Public Domain eBooks
 - Manual For Hlt26cd Manuel eBook Subscription Services
 - Manual For Hlt26cd Manuel Budget-Friendly Options
- 6. Navigating Manual For Hlt26cd Manuel eBook Formats
 - ePub, PDF, MOBI, and More
 - Manual For Hlt26cd Manuel Compatibility with Devices
 - Manual For Hlt26cd Manuel Enhanced eBook Features
- 7. Enhancing Your Reading Experience
 - Adjustable Fonts and Text Sizes of Manual For Hlt26cd Manuel
 - Highlighting and Note-Taking Manual For Hlt26cd Manuel
 - Interactive Elements Manual For Hlt26cd Manuel
- 8. Staying Engaged with Manual For Hlt26cd Manuel
 - Joining Online Reading Communities
 - Participating in Virtual Book Clubs
 - Following Authors and Publishers Manual For Hlt26cd Manuel

9. Balancing eBooks and Physical Books Manual For Hlt26cd Manuel
 - Benefits of a Digital Library
 - Creating a Diverse Reading Collection Manual For Hlt26cd Manuel
10. Overcoming Reading Challenges
 - Dealing with Digital Eye Strain
 - Minimizing Distractions
 - Managing Screen Time
11. Cultivating a Reading Routine Manual For Hlt26cd Manuel
 - Setting Reading Goals Manual For Hlt26cd Manuel
 - Carving Out Dedicated Reading Time
12. Sourcing Reliable Information of Manual For Hlt26cd Manuel
 - Fact-Checking eBook Content of Manual For Hlt26cd Manuel
 - Distinguishing Credible Sources
13. Promoting Lifelong Learning
 - Utilizing eBooks for Skill Development
 - Exploring Educational eBooks
14. Embracing eBook Trends
 - Integration of Multimedia Elements
 - Interactive and Gamified eBooks

Manual For Hlt26cd Manuel Introduction

In today's digital age, the availability of Manual For Hlt26cd Manuel books and manuals for download has revolutionized the way we access information. Gone are the days of physically flipping through pages and carrying heavy textbooks or manuals. With just a few clicks, we can now access a wealth of knowledge from the comfort of our own homes or on the go. This article will explore the advantages of Manual For Hlt26cd Manuel books and manuals for download, along with some popular platforms that offer these resources. One of the significant advantages of Manual For Hlt26cd Manuel books and manuals for download is the cost-saving aspect. Traditional books and manuals can be costly, especially if you need to purchase several of them for educational or professional purposes. By accessing Manual For Hlt26cd Manuel versions, you eliminate the need to spend money on physical copies. This not only saves you money but also reduces the environmental impact associated with book production and transportation. Furthermore, Manual For Hlt26cd Manuel books and manuals for download are

incredibly convenient. With just a computer or smartphone and an internet connection, you can access a vast library of resources on any subject imaginable. Whether you're a student looking for textbooks, a professional seeking industry-specific manuals, or someone interested in self-improvement, these digital resources provide an efficient and accessible means of acquiring knowledge. Moreover, PDF books and manuals offer a range of benefits compared to other digital formats. PDF files are designed to retain their formatting regardless of the device used to open them. This ensures that the content appears exactly as intended by the author, with no loss of formatting or missing graphics. Additionally, PDF files can be easily annotated, bookmarked, and searched for specific terms, making them highly practical for studying or referencing. When it comes to accessing Manual For Hlt26cd Manuel books and manuals, several platforms offer an extensive collection of resources. One such platform is Project Gutenberg, a nonprofit organization that provides over 60,000 free eBooks. These books are primarily in the public domain, meaning they can be freely distributed and downloaded. Project Gutenberg offers a wide range of classic literature, making it an excellent resource for literature enthusiasts. Another popular platform for Manual For Hlt26cd Manuel books and manuals is Open Library. Open Library is an initiative of the Internet Archive, a nonprofit organization dedicated to digitizing cultural artifacts and making them accessible to the public. Open Library hosts millions of books, including both public domain works and contemporary titles. It also allows users to borrow digital copies of certain books for a limited period, similar to a library lending system. Additionally, many universities and educational institutions have their own digital libraries that provide free access to PDF books and manuals. These libraries often offer academic texts, research papers, and technical manuals, making them invaluable resources for students and researchers. Some notable examples include MIT OpenCourseWare, which offers free access to course materials from the Massachusetts Institute of Technology, and the Digital Public Library of America, which provides a vast collection of digitized books and historical documents. In conclusion, Manual For Hlt26cd Manuel books and manuals for download have transformed the way we access information. They provide a cost-effective and convenient means of acquiring knowledge, offering the ability to access a vast library of resources at our fingertips. With platforms like Project Gutenberg, Open Library, and various digital libraries offered by educational institutions, we have access to an ever-expanding collection of books and manuals. Whether for educational, professional, or personal purposes, these digital resources serve as valuable tools for continuous learning and self-improvement. So why not take advantage of the vast world of Manual For Hlt26cd Manuel books and manuals for download and embark on your journey of knowledge?

FAQs About Manual For Hlt26cd Manuel Books

What is a Manual For Hlt26cd Manuel PDF? A PDF (Portable Document Format) is a file format developed by Adobe that

preserves the layout and formatting of a document, regardless of the software, hardware, or operating system used to view or print it. **How do I create a Manual For Hlt26cd Manuel PDF?** There are several ways to create a PDF: Use software like Adobe Acrobat, Microsoft Word, or Google Docs, which often have built-in PDF creation tools. Print to PDF: Many applications and operating systems have a "Print to PDF" option that allows you to save a document as a PDF file instead of printing it on paper. Online converters: There are various online tools that can convert different file types to PDF. **How do I edit a Manual For Hlt26cd Manuel PDF?** Editing a PDF can be done with software like Adobe Acrobat, which allows direct editing of text, images, and other elements within the PDF. Some free tools, like PDFescape or Smallpdf, also offer basic editing capabilities. **How do I convert a Manual For Hlt26cd Manuel PDF to another file format?** There are multiple ways to convert a PDF to another format: Use online converters like Smallpdf, Zamzar, or Adobe Acrobat's export feature to convert PDFs to formats like Word, Excel, JPEG, etc. Software like Adobe Acrobat, Microsoft Word, or other PDF editors may have options to export or save PDFs in different formats. **How do I password-protect a Manual For Hlt26cd Manuel PDF?** Most PDF editing software allows you to add password protection. In Adobe Acrobat, for instance, you can go to "File" -> "Properties" -> "Security" to set a password to restrict access or editing capabilities. Are there any free alternatives to Adobe Acrobat for working with PDFs? Yes, there are many free alternatives for working with PDFs, such as: LibreOffice: Offers PDF editing features. PDFsam: Allows splitting, merging, and editing PDFs. Foxit Reader: Provides basic PDF viewing and editing capabilities. How do I compress a PDF file? You can use online tools like Smallpdf, ILovePDF, or desktop software like Adobe Acrobat to compress PDF files without significant quality loss. Compression reduces the file size, making it easier to share and download. Can I fill out forms in a PDF file? Yes, most PDF viewers/editors like Adobe Acrobat, Preview (on Mac), or various online tools allow you to fill out forms in PDF files by selecting text fields and entering information. Are there any restrictions when working with PDFs? Some PDFs might have restrictions set by their creator, such as password protection, editing restrictions, or print restrictions. Breaking these restrictions might require specific software or tools, which may or may not be legal depending on the circumstances and local laws.

Find Manual For Hlt26cd Manuel :

imu cet question paper

[inclined plane sliding objects gizmo answers](#)

[implementing appfog rabinovitch isaac](#)

[imp by imp inc recipe file](#)

[imprisonment at ironfist and other stories](#)

[important of hsc chemistry part 1](#)

[impossible dream noten kostenlos](#)

[impluse turbine lab manual](#)

[imaje 9020 user manual](#)

[increment for grade r](#)

[impact factor scientific journals 2012 list](#)

[incident response pocket guide 2015](#)

[impak exam papers gr11](#)

[income tax fundamentals 2whittenburg 31st edition solutions manual](#)

[independent medical examination guidelines](#)

Manual For Hlt26cd Manuel :

[syntax worksheets](#) - Jul 31 2022

web syntax exercises the following questions relate to the lecture notes and exercises for the syntax topic n noun v verb a adjective p preposition det determiner prn

[grammar arts and humanities khan academy](#) - Jan 05 2023

web basic exercises in syntax 1 draw a labelled tree diagram for the following english phrases hint what part of speech is the leader for the phrase a ancient pyramids b

[what is syntax definition rules and examples grammarly](#) - Mar 07 2023

web phrases and clauses syntax sentences and clauses unit 9 syntax conventions of standard english subject verb agreement and pronoun antecedent agreement syntax

[an introduction to syntax cambridge university press](#) - May 09 2023

web apr 29 2022 when it comes to language syntax is an advanced topic which can make it difficult to understand in this guide we discuss the basic rules and types of syntax so

[python syntax w3schools](#) - Nov 22 2021

[syntax exercise worksheet live worksheets](#) - Apr 27 2022

web in the english language there are a few basic syntactic patterns based on which longer sentences are built let us look at the basic sentence patterns in english syntactic

[syntax worksheets esl printables](#) - Oct 02 2022

web syntax worksheets to print put the sentences in order put each set of words in order to make a clear thought that is

worth expressing declare something put the words in

basic english syntax with exercises u szeged hu - Dec 24 2021

the basics of syntax linguistics network - Sep 01 2022

web jan 24 2020 in linguistics syntax refers to the rules that govern the ways in which words combine to form phrases clauses and sentences the term syntax comes from the

syntax exercises university of birmingham - Jan 25 2022

web execute python syntax python indentation python variables python comments exercises or by creating a python file on the server using the py file extension and running it in

basic exercises in syntax pdf syntax phrase scribd - Nov 03 2022

web the basics of syntax syntax is the study of grammatical relationships between words and how they are combined to form phrases and sentences the word syntax has its roots

pdf basic english syntax with exercises - Jun 10 2023

web active voice the active form expresses the idea of something or someone performing an action this person or thing performing the action in grammar b1 unit 5 2 adjectives

syntax exercises linguistics network - Oct 14 2023

web syntax exercises syntax is the study of phrase and sentence structure sentences are not simply linear strings of words but are phrases which are linked together in hierarchical structures

clause structure and verb patterns learnenglish british council - Dec 04 2022

web song mercy by duffy syntax activities level intermediate age 13 17 downloads 123 syntax exercises phrasal verbs vs prepositional verbs adjunct

list of exercises on sentences and syntax in english - Aug 12 2023

web practise your english grammar with clear grammar explanations and practice exercises to test your understanding the learning materials are organised into two sections

component syntax english exercises - Apr 08 2023

web jan 23 2021 i am new to the field of linguistics and i was looking for some books in order to learn syntax i put my eyes on two main textbooks basic english syntax with

[syntax exercises university of birmingham](#) - May 29 2022

web basic exercises in syntax exercises in english syntax jun 10 2023 an old english grammar and exercise book nov 22 2021 trieste publishing has a massive catalogue

grammar learnenglish - Jul 11 2023

web exercises 169 6 theories of syntax 172 6 0 introduction 172 6 1 relational grammar 173 6 2 lexical functional grammar 182 this book is an introduction to the basic

basic exercises in syntax 2023 cyberlab sutd edu sg - Mar 27 2022

web syntax exercises the following questions relate to the lecture notes and exercises for the syntax topic 2 identify all the nps pps and vps in the following sentences allow

best book for introduction to syntax with exercises - Feb 06 2023

web level elementary clause structure all clauses in english have at least two parts a noun phrase subject and a verb phrase but most clauses have more than two parts the first

syntax meaning definition rules and examples byju s - Feb 23 2022

web in order to get this page properly java must be installed on your computer install java the pdf version of this material can be downloaded here here

syntax sentences and clauses grammar khan academy - Sep 13 2023

web exercises on word order and syntax here you will find an overview of exercises on sentences clauses and syntax in english new quizzes are added continually so check

[syntax definition and examples thoughtco](#) - Jun 29 2022

web dec 27 2021 [syntax exercise liveworksheets](#) transforms your traditional printable worksheets into self correcting interactive exercises that the students can do online and

[module 1 wcc new lecture notes of wireless communication](#) - Oct 27 2022

web wireless and cellular communication course code 18ec81 cie marks 40 lecture hours week 03 see marks 60 total number of lecture hours 40 08 hrs

17ec81 wireless cellular and lte 4g broadband vtu notes - Jan 18 2022

pdf wireless communication notes vtu - Mar 20 2022

web 5th module covers brief history of wireless communications advantages of wireless communication disadvantages of wireless communications download the 2018

cbcs ece notes archives vtupulse - Dec 29 2022

web wireless communication unit1 2 3 4 5 6 7 8 download notes question banks and other study material studocu you don t have any studylists yet

[wireless communication vtu notes pdf 2023 2024 eduvark](#) - Apr 20 2022

web 17ec81 wireless cellular and lte 4g broadband vtu cbs notes here you can download the vtu cbs 2017 scheme notes and study materials of wireless cellular

vtu wireless communication question papers te 7th sem - Nov 27 2022

web 15ec753 17753 pattern recognition vtu cbs notes 15ec752 17ec752 iot and wireless sensor networks vtu cbs notes 15ec754 17ec754 advanced

wireless network and communications 1st module - Jun 03 2023

web jul 12 2020 18ec81 wireless and cellular communication ece syllabus for be 8th sem 2018 scheme vtu wireless and cellular communication detailed syllabus for

wireless communication unit1 2 3 4 5 6 7 8 download notes - Sep 25 2022

web get wireless communication notes in pdf format at smartzworld free wc pdf notes lecturer notes study material download now for a deeper understanding next web

vtu wireless communication notes pdf 2023 2024 eduvark - Feb 16 2022

web download 2018 scheme vtu cbs notes and study materials of electronics and communication engineering branch electronics and communication engineering

18ec81 wireless and cellular communication notes vtupulse - Oct 07 2023

web 18ec81 wireless and cellular communication vtu cbs notes here you can download the vtu 2018 scheme notes and study materials of 18ec71 computer networks of the

wireless communications and networks notes - Jun 22 2022

web wireless communication notes vtu communication software and networks sep 16 2021 this book highlights a collection of high quality peer reviewed research papers

wireless network and communications 4th module - Apr 01 2023

web download final year projects wptelegram join channel 18ec81 wireless and cellular communication vtu cbs notes here you can download the vtu 2018 scheme

wireless communication 18te72 az documents - Sep 06 2023

web 1 explain concepts of propagation mechanisms like reflection diffraction scattering in wireless channels 2 analyse signal received levels for simple channels involving two

18ec81 wireless and cellular communication ece all about - Feb 28 2023

web jan 23 2023 download vtu wireless communication of 7th semester telecommunication engineering with subject code 18te72 2018 scheme question

wireless communication and 4g lte networks 15ec81 vtu - Aug 05 2023

web studying wireless communication and 4g lte networks 15ec81 at visvesvaraya technological university on studocu you will find 172 lecture notes practice materials

18ec751 communication theory vtu cbcs notes vtupulse - Dec 17 2021

wireless communication for 8th sem ec vtu students - Jul 04 2023

web jan 24 2023 vtu exam syllabus of wireless and cellular communication for electronics and communication engineering eighth semester 2018 scheme

electronics and communications engineering notes vtupulse - Aug 25 2022

web wireless communications and networks lecture notes b tech iv year ii sem 2017 18 prepared by m arun kumar assoc professor maheswari

wireless communications and networks lecture - May 22 2022

web mar 29 2017 introduction to wireless lan 802 11x technologies evolution of wireless lan intro for any query you mat contact to the vtu university the contact details are

2018 scheme electronics and communication vtu cbcs notes - Nov 15 2021

18ec81 wireless and cellular communication syllabus for ec - May 02 2023

web 18ec81 2018 22 visvesvaraya technological university belagavi 3 rd to 8 th semester be studocu wireless communication and 4g lte networks 15ec81

wireless and cellular communication 18ec81 az - Jul 24 2022

web oct 13 2016 as per your request here i am giving you syllabus notes for wireless communication subject for ece students of visvesvaraya technological university

18ec81 2018 22 visvesvaraya technological - Jan 30 2023

web module 1 wcc new lecture notes of wireless communication of vtu university university visvesvaraya technological university course wireless cellular communication

boots mds medication administration record pdf byu11 mainsu - Sep 04 2022

web download any of our books in the same way as this one merely said the boots mds medication administration record pdf is universally compatible subsequently any devices to read

boots can help you to give effective medication to patients safely - Dec 07 2022

web jun 28 2012 here s a brief description of our elearning courses monitored dosage system this module is designed to enable the delegate to handle medicines safely through the correct implementation of the boots monitored dosage system

mds

mds ops manual 28pp aw boots - Jul 14 2023

web medication records this is to be determined by the home there are two sets of files for each home one in use and one to be assembled medication administration review request marr record this is a three part record produced from patient medication records in the pharmacy and used by the home also available a ring binder to hold

104628 mds booklet pdf4pro - Apr 11 2023

web full set of computer generated medication administration records marr sheets every 28 days the marr sheets facilitate a robust auditing procedure for record keeping ordering and receiving repeat prescriptions and stock control mds boots monitored dosage system 104628 mds booklet 1 20 06 9 30 am page 6

boots mds medication administration record pdf my protechguy - Aug 03 2022

web boots mds medication administration record downloaded from my protechguy com by guest anastasia harrell congressional intern handbook springer publishing company

boots pharmacy online nhs repeat prescriptions free delivery - Mar 30 2022

web delivery orders are looked after by our expert team at the boots online prescription service 30 36 gallowtree gate leicester le1 1dd to check who the responsible pharmacist was at the time your medicine was supplied you can contact the boots pharmacy leicester by phone on 0345 121 9040 between 11am and 4pm

boots mds medication administration record uniport edu - Apr 30 2022

web jun 16 2023 boots mds medication administration record 1 7 downloaded from uniport edu ng on june 16 2023 by guest boots mds medication administration record this is likewise one of the factors by obtaining the soft documents of this boots mds medication administration record by online you might not require more grow old to

boots care services - Aug 15 2023

web our paper and computer records provide a clear audit trail for regulators covering receipt administration ordering and return of medication we can also supply your home with supplementary medication administration records mar such as topical medicines administration records tmar so your team can record usage of creams lotions

boots mds medication administration record - Jan 28 2022

web boots mds medication administration record author sending storage 10 jangomail com 2023 08 18 01 56 04 subject boots mds medication administration record keywords boots mds medication administration record created date 8 18 2023 1 56 04 am

elearning ustomer support pack boots - Feb 09 2023

web course contents this module provides the learner with the knowledge to use the monitored dosage system and manage

medication handling within the care home setting a competency assessment is available at the end of the module for the learner to complete before unsupervised medication administration

boots mds medication administration record pdf full pdf - Oct 05 2022

web boots mds medication administration record pdf introduction boots mds medication administration record pdf full pdf

boots to switch from monitored dosage systems to patient pack - Jan 08 2023

web feb 12 2021 boots care services customers were sent a letter in january 2019 informing them that the change was being made in line with recommendations from the national institute for health and care excellence nice royal

pharmaceutical society rps which were issued in 2014 and 2012 respectively and called for the supply of medicines in

boots mds medication administration record pdf 2023 - Jul 02 2022

web boots mds medication administration record pdf introduction boots mds medication administration record pdf 2023

boots uk care services - Jun 13 2023

web emar at boots care services boots continues to lead the way in digital innovation with successful implementations as more and more care home organisations switch from paper based to electronic medicines administration record emar

systems here are some of the benefits of using emar at boots

boots mds medication administration record 2022 - Feb 26 2022

web boots mds medication administration record 3 3 associated vasculitis lippincott williams wilkins guiding patient behavior is as important as ever for the practicing dentist and the behavior of pediatric patients is perhaps the most challenging to

manage drs wright and kupietzky here update dr wright s classic work on managing pediatric

boots mds medication administration record - Dec 27 2021

web boots mds medication administration record news breaking stories amp updates telegraph may 6th 2018 latest breaking news including politics crime and celebrity find stories updates and expert opinion uptodate may 6th 2018 you can also

locate patient education articles on a variety of subjects by searching on patient info

download a free medication administration record here - Mar 10 2023

web jan 27 2021 free patch administration record download now you can download our patch administration record for free here more ordering medication using proxy access guidance for care homes and gp practices last update 16 11 20

boots pharmacy online nhs repeat prescriptions free delivery - Jun 01 2022

web boots pharmacy is supporting the nhs to help patients manage their repeat prescriptions online including reminders to reorder gp online services are also available so patients can manage appointment booking and view their medical record

choose from free delivery in england or free collection from pharmacy

care of medicines foundation module boots - Nov 06 2022

web topical medicines applying topical medicines transdermal patches inhalers other routes of administration side effects importance of medication reviews the law medication administration record and request mar verbal instructions for dosage alteration storage giving the medicines

monitored dosage system 0115 949 5421 boots - May 12 2023

web to ensure there s a clear audit trail for every step of the process we provide you with computer generated medicationadministration records marr sheets every 28 days these help you with record keeping ordering and receivingrepeat prescriptions and stock holding