

1050-020

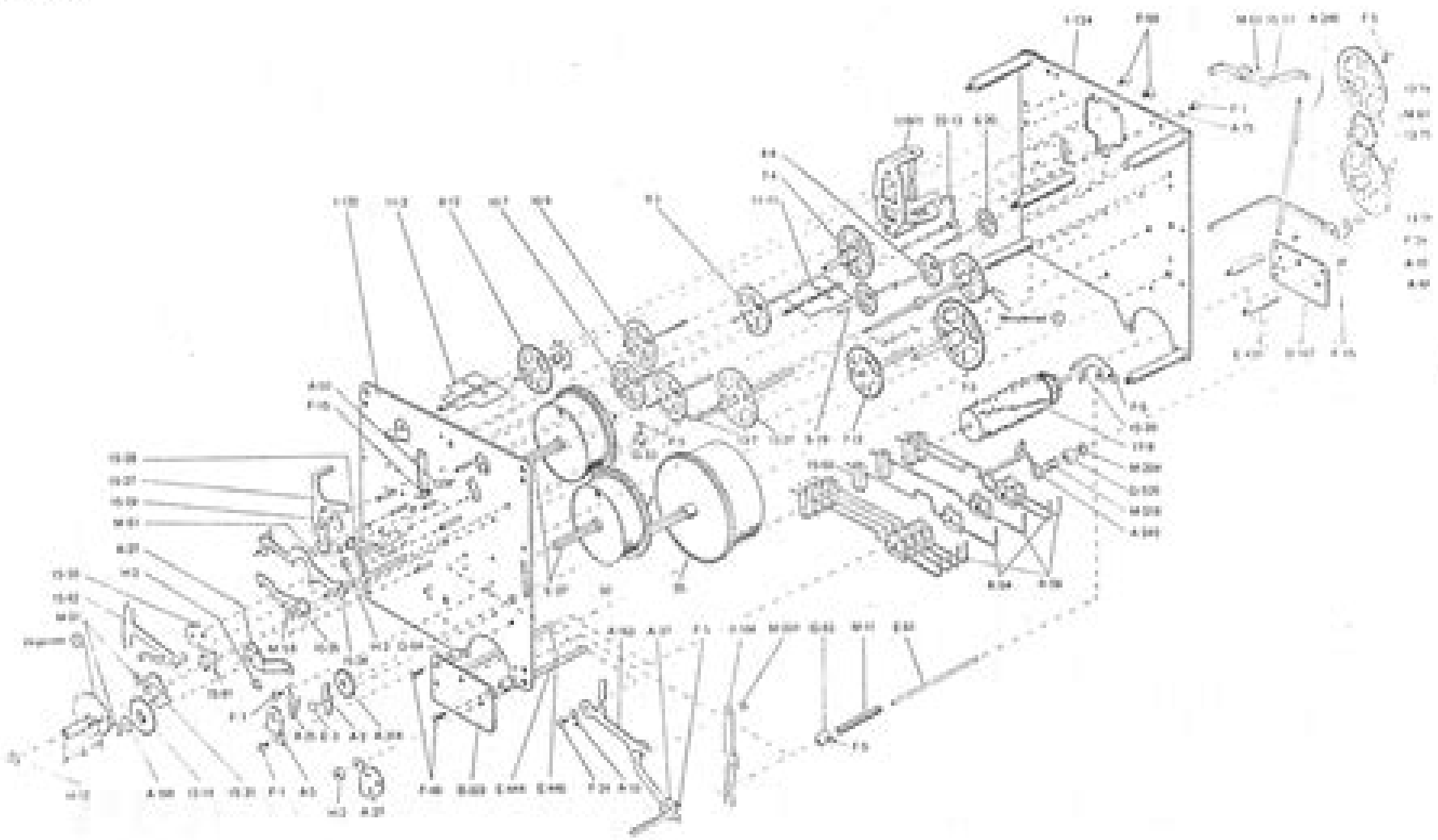

# Hermle 340 020 Manual

**J Ma**



## **Hermle 340 020 Manual:**

The book delves into Hermle 340 020 Manual. Hermle 340 020 Manual is an essential topic that must be grasped by everyone, ranging from students and scholars to the general public. This book will furnish comprehensive and in-depth insights into Hermle 340 020 Manual, encompassing both the fundamentals and more intricate discussions.

1. The book is structured into several chapters, namely:
  - Chapter 1: Introduction to Hermle 340 020 Manual
  - Chapter 2: Essential Elements of Hermle 340 020 Manual
  - Chapter 3: Hermle 340 020 Manual in Everyday Life
  - Chapter 4: Hermle 340 020 Manual in Specific Contexts
  - Chapter 5: Conclusion
2. In chapter 1, this book will provide an overview of Hermle 340 020 Manual. The first chapter will explore what Hermle 340 020 Manual is, why Hermle 340 020 Manual is vital, and how to effectively learn about Hermle 340 020 Manual.
3. In chapter 2, this book will delve into the foundational concepts of Hermle 340 020 Manual. This chapter will elucidate the essential principles that need to be understood to grasp Hermle 340 020 Manual in its entirety.
4. In chapter 3, the author will examine the practical applications of Hermle 340 020 Manual in daily life. The third chapter will showcase real-world examples of how Hermle 340 020 Manual can be effectively utilized in everyday scenarios.
5. In chapter 4, the author will scrutinize the relevance of Hermle 340 020 Manual in specific contexts. The fourth chapter will explore how Hermle 340 020 Manual is applied in specialized fields, such as education, business, and technology.
6. In chapter 5, the author will draw a conclusion about Hermle 340 020 Manual. The final chapter will summarize the key points that have been discussed throughout the book.

The book is crafted in an easy-to-understand language and is complemented by engaging illustrations. This book is highly recommended for anyone seeking to gain a comprehensive understanding of Hermle 340 020 Manual.

<https://staging.conocer.cide.edu/About/uploaded-files/index.jsp/le%20sa%20na%20gal%20aujourd'hui.pdf>

## **Table of Contents Hermle 340 020 Manual**

1. Understanding the eBook Hermle 340 020 Manual

- The Rise of Digital Reading Hermle 340 020 Manual
- Advantages of eBooks Over Traditional Books
- 2. Identifying Hermle 340 020 Manual
  - Exploring Different Genres
  - Considering Fiction vs. Non-Fiction
  - Determining Your Reading Goals
- 3. Choosing the Right eBook Platform
  - Popular eBook Platforms
  - Features to Look for in an Hermle 340 020 Manual
  - User-Friendly Interface
- 4. Exploring eBook Recommendations from Hermle 340 020 Manual
  - Personalized Recommendations
  - Hermle 340 020 Manual User Reviews and Ratings
  - Hermle 340 020 Manual and Bestseller Lists
- 5. Accessing Hermle 340 020 Manual Free and Paid eBooks
  - Hermle 340 020 Manual Public Domain eBooks
  - Hermle 340 020 Manual eBook Subscription Services
  - Hermle 340 020 Manual Budget-Friendly Options
- 6. Navigating Hermle 340 020 Manual eBook Formats
  - ePub, PDF, MOBI, and More
  - Hermle 340 020 Manual Compatibility with Devices
  - Hermle 340 020 Manual Enhanced eBook Features
- 7. Enhancing Your Reading Experience
  - Adjustable Fonts and Text Sizes of Hermle 340 020 Manual
  - Highlighting and Note-Taking Hermle 340 020 Manual
  - Interactive Elements Hermle 340 020 Manual
- 8. Staying Engaged with Hermle 340 020 Manual
  - Joining Online Reading Communities
  - Participating in Virtual Book Clubs
  - Following Authors and Publishers Hermle 340 020 Manual

9. Balancing eBooks and Physical Books Hermle 340 020 Manual
  - Benefits of a Digital Library
  - Creating a Diverse Reading Collection Hermle 340 020 Manual
10. Overcoming Reading Challenges
  - Dealing with Digital Eye Strain
  - Minimizing Distractions
  - Managing Screen Time
11. Cultivating a Reading Routine Hermle 340 020 Manual
  - Setting Reading Goals Hermle 340 020 Manual
  - Carving Out Dedicated Reading Time
12. Sourcing Reliable Information of Hermle 340 020 Manual
  - Fact-Checking eBook Content of Hermle 340 020 Manual
  - Distinguishing Credible Sources
13. Promoting Lifelong Learning
  - Utilizing eBooks for Skill Development
  - Exploring Educational eBooks
14. Embracing eBook Trends
  - Integration of Multimedia Elements
  - Interactive and Gamified eBooks

### **Hermle 340 020 Manual Introduction**

Hermle 340 020 Manual Offers over 60,000 free eBooks, including many classics that are in the public domain. Open Library: Provides access to over 1 million free eBooks, including classic literature and contemporary works. Hermle 340 020 Manual Offers a vast collection of books, some of which are available for free as PDF downloads, particularly older books in the public domain. Hermle 340 020 Manual : This website hosts a vast collection of scientific articles, books, and textbooks. While it operates in a legal gray area due to copyright issues, its a popular resource for finding various publications. Internet Archive for Hermle 340 020 Manual : Has an extensive collection of digital content, including books, articles, videos, and more. It has a massive library of free downloadable books. Free-eBooks Hermle 340 020 Manual Offers a diverse range of free eBooks across various genres. Hermle 340 020 Manual Focuses mainly on educational books, textbooks, and business books. It offers free PDF downloads for educational purposes. Hermle 340 020 Manual Provides a large selection of free

eBooks in different genres, which are available for download in various formats, including PDF. Finding specific Hermle 340 020 Manual, especially related to Hermle 340 020 Manual, might be challenging as they're often artistic creations rather than practical blueprints. However, you can explore the following steps to search for or create your own Online Searches: Look for websites, forums, or blogs dedicated to Hermle 340 020 Manual, Sometimes enthusiasts share their designs or concepts in PDF format. Books and Magazines Some Hermle 340 020 Manual books or magazines might include. Look for these in online stores or libraries. Remember that while Hermle 340 020 Manual, sharing copyrighted material without permission is not legal. Always ensure you're either creating your own or obtaining them from legitimate sources that allow sharing and downloading. Library Check if your local library offers eBook lending services. Many libraries have digital catalogs where you can borrow Hermle 340 020 Manual eBooks for free, including popular titles. Online Retailers: Websites like Amazon, Google Books, or Apple Books often sell eBooks. Sometimes, authors or publishers offer promotions or free periods for certain books. Authors Website Occasionally, authors provide excerpts or short stories for free on their websites. While this might not be the Hermle 340 020 Manual full book, it can give you a taste of the author's writing style. Subscription Services Platforms like Kindle Unlimited or Scribd offer subscription-based access to a wide range of Hermle 340 020 Manual eBooks, including some popular titles.

### **FAQs About Hermle 340 020 Manual Books**

1. Where can I buy Hermle 340 020 Manual books? Bookstores: Physical bookstores like Barnes & Noble, Waterstones, and independent local stores. Online Retailers: Amazon, Book Depository, and various online bookstores offer a wide range of books in physical and digital formats.
2. What are the different book formats available? Hardcover: Sturdy and durable, usually more expensive. Paperback: Cheaper, lighter, and more portable than hardcovers. E-books: Digital books available for e-readers like Kindle or software like Apple Books, Kindle, and Google Play Books.
3. How do I choose a Hermle 340 020 Manual book to read? Genres: Consider the genre you enjoy (fiction, non-fiction, mystery, sci-fi, etc.). Recommendations: Ask friends, join book clubs, or explore online reviews and recommendations. Author: If you like a particular author, you might enjoy more of their work.
4. How do I take care of Hermle 340 020 Manual books? Storage: Keep them away from direct sunlight and in a dry environment. Handling: Avoid folding pages, use bookmarks, and handle them with clean hands. Cleaning: Gently dust the covers and pages occasionally.

5. Can I borrow books without buying them? Public Libraries: Local libraries offer a wide range of books for borrowing. Book Swaps: Community book exchanges or online platforms where people exchange books.
6. How can I track my reading progress or manage my book collection? Book Tracking Apps: Goodreads, LibraryThing, and Book Catalogue are popular apps for tracking your reading progress and managing book collections. Spreadsheets: You can create your own spreadsheet to track books read, ratings, and other details.
7. What are Hermle 340 020 Manual audiobooks, and where can I find them? Audiobooks: Audio recordings of books, perfect for listening while commuting or multitasking. Platforms: Audible, LibriVox, and Google Play Books offer a wide selection of audiobooks.
8. How do I support authors or the book industry? Buy Books: Purchase books from authors or independent bookstores. Reviews: Leave reviews on platforms like Goodreads or Amazon. Promotion: Share your favorite books on social media or recommend them to friends.
9. Are there book clubs or reading communities I can join? Local Clubs: Check for local book clubs in libraries or community centers. Online Communities: Platforms like Goodreads have virtual book clubs and discussion groups.
10. Can I read Hermle 340 020 Manual books for free? Public Domain Books: Many classic books are available for free as they're in the public domain. Free E-books: Some websites offer free e-books legally, like Project Gutenberg or Open Library.

### **Find Hermle 340 020 Manual :**

[le sa na gal aujourdhui](#)

**leadership and management-online training indv**

[leaders and lesser mortals backroom politics in canada](#)

[le printemps stances et odes](#)

[leadership defined](#)

[leaderships greatest hits](#)

**leadership and the new science learning about organization from an orderly universe**

**leadership secrets of colin powell**

[le pont victoria un lien vital victoria bridge the vital link](#)

[learn microsoft active desktop programming using windows 98](#)

[learn live](#)



[leaf-cutting ants](#)

[le systame juridique de lunion europaeenne](#)

[learning american sign language levels i & ii--beginning & intermediate with dvd text & dvd package](#)

[le premier homme](#)

### **Hermle 340 020 Manual :**

[data communication and networking challenges and solutions](#) - May 17 2023

communication networks involving both wired and wireless scenarios to track the follow up research a public github repository is created where the relevant papers will be updated

**btech ec 7 sem data communication networks rec701 2021 pdf** - Sep 09 2022

our website provides solved previous year question paper for data communication networking from 2017 to 2018 doing preparation from the previous year question paper helps you to get

**data communication and computer network online tutorials** - Nov 30 2021

may 19 2023 dict data communication and networking may 19 2023 admin advertisement nb if you wish to download these notes please contact us

*data communications and networking issues in real world* - Jun 18 2023

jun 23 2023 pdf p three challenges were assessed in the realm of networking and data communication network security network performance and scalability it is find read

[huawei and caict jointly launch xinghe network white paper](#) - Jan 13 2023

jun 14 2023 pdf p this paper discusses the issues and challenges that can be found in data communication and networking as well as possible solutions to those issues find read

[bitcoin s btc scaling solution lightning network reboots after](#) - Jun 25 2021

**proposed secure routing algorithm in the iot sraiot nature** - Feb 14 2023

past exam papers computer networking solution notes are available for many past questions to local users they were produced by question setters primarily for the benefit of the

*data communication and networking edu notes* - Aug 28 2021

this review paper discusses the main problems with data networking and communication analyses the research being done to solve these problems and discusses possible solutions

[solution manual for data communications and](#) - Oct 10 2022

ims college page 11 data communication and computer networks chapter 3 computer communication architecture network connections in action note the flow of data from user

**iflytek and huawei jointly initiate the** - Oct 30 2021

oct 16 2023 the top strategic technology trends for 2024 are democratized generative ai generative ai genai is becoming democratized by the confluence of massively pretrained

**challenges in transmission of data and network** - Apr 16 2023

oct 21 2023 for this purpose the iot network is first divided into a set of subnets using the sdn solution communication control and authentication are managed using the controller

**data communication and networking notes pdf 2023 b tech** - Apr 04 2022

upload soon androbose provides solved previous year question papers for bcom ba bsc bca ma pgdca mcom msc addon bba doing preparation from the previous year s

pdf data communication networking - Aug 20 2023

networks sensor networks vehicular networks underwater networks airborne networks underground networks personal area networks device to device d2d communications in

*past exam papers computer networking department of* - Dec 12 2022

aktu btech ec 7 sem data communication networks rec701 2021 pdf question paper with solutions notes pdf download aktu dr a p j abdul kalam technical university lucknow

challenges in data communication and networking researchgate - Nov 11 2022

computer networking and data communication solved question paper free download as pdf file pdf text file txt or read online for free computer networking and data

data communication network paper solution book - Jul 19 2023

jun 28 2023 this review paper explores the key challenges encountered in data communication and networking and discusses potential solutions to address these issues

**computer networking and data communication solved question** - Aug 08 2022

the five components of a data communication system are the sender receiver transmission medium message and protocol 2 the advantages of distributed processing are security

data communication and networking challenges and solutions - Sep 21 2023

jun 28 2023 this review paper explores the key challenges encountered in data communication and networking and discusses potential solutions to address these issues

data communication and networking challenges and solutions - May 25 2021

[download data communication and networking 2021](#) - Feb 02 2022

sep 20 2023 at huawei connect 2023 iflytek and huawei data center network dcn initiated a joint innovation project to build a super connectivity ai base the overarching aim is

**gartner identifies the top 10 strategic technology trends for 2024** - Jul 27 2021

**data communication and computer networks aminotes** - Mar 03 2022

data communication and computer network 8 let us go through various lan technologies in brief ethernet ethernet is a widely deployed lan technology this technology was invented

*solution manual for data communications and networking by* - May 05 2022

in this blog you will get all the previous years data communication and networking 2021 papers along with that previous year s question papers for consumer electronics

[pgdca data communications and networks question paper with](#) - Jan 01 2022

jun 11 2023 merely said the data communication network paper solution is universally compatible taking into consideration any devices to read innovative data communication

*data communication and computer networks chapter 3* - Jul 07 2022

mar 21 2020 data communication and networking lecture notes include data communication and networking notes data communication and networking book data

**data communication network paper solution pdf uniport edu** - Sep 28 2021

oct 16 2023 since its inception lightning labs has raised 82 5 million in funding compared with one of ethereum s leading layer 2 solutions polygon which brought around 450

*mdu previous years question papers download brpaper com* - Jun 06 2022

labels cse302 3rd year 3rd year question paper aset in this post you will find the previous year question paper for the subject data communication and computer networks dcn is

*graph based deep learning for communication networks a* - Mar 15 2023

sep 20 2023 during huawei connect 2023 xinghe network white paper was jointly released by huawei china academy of information and communications technology

[patta transfer cla tn](#) - Nov 29 2022

web patta transfer government in their g o perm no 210 revenue ss 1 1 department dated 8 7 2011 have issued instructions for disposing the patta transfer applications in respect of not involving sub division and involving sub division

[how to apply for patta in tamil nadu eservices tn gov in](#) - Aug 27 2022

web jul 21 2023 the revenue department s patta is a land revenue document that proves land ownership and title a patta contains the landowner s name the patta number the survey number the sub division number information on the district taluk and village the land s area and whether the property is dry or wetland

[eservices of district offices tamil nadu government portal](#) - Mar 22 2022

web nov 9 2023 revenue and disaster management department back edistrict services certificates mutation of revenue records record of rights ror last updated nov 09 2023

[புதுப்பிக்கப்பட்டது](#) - Jun 05 2023

web [புதுப்பிக்கப்பட்டது](#)

[department of revenue tamil nadu wikipedia](#) - Feb 18 2022

web objective functions of the department 1 providing efficient delivery of services of various government schemes to the people of tamil nadu 2 providing relief and implementing rehabilitation measures for those affected by natural calamities 3 functioning as the custodian of government lands and ensuring proper maintenance of

**service tamil nadu government portal** - Dec 31 2022

web nov 9 2023 revenue and disaster management department back organisation name revenue administration category government to citizen service title view chitta patta copy description view chitta patta extract url contents owned and updated by concerned departments and coordinated by information technology department

**application form for transfer of registry in tamil nadu** - May 24 2022

web application form to apply for transfer of registry patta in tamil nadu is given this form is provided by the revenue department of tn information about documents to be attached is given

[view patta fmb chitta tslr extract eservices taluk](#) - Oct 09 2023

web view patta fmb chitta tslr extract eservices taluk offices land records view patta fmb chitta tslr extract *commissionerate of survey and settlement* - Jul 26 2022

web directorate of survey and settlement central survey office survey house pwd estate chepauk triplicane chepauk chennai 600005 tnlandsurvey tn gov in 044 28591662 customerservice tnlandrecords at tn gov in *e services of land records tamilnadu government tn* - Apr 03 2023

web government of tamil nadu s anytime anywhere e services enable citizens to view and verify pattas a register extracts also track application status find out if a land is owned by the government or by a private entity

[register tamil nilam citizen portal tn](#) - Mar 02 2023

web [புதுப்பிக்கப்பட்டது](#) citizen portal is not enabled for natham rural and urban areas for more info click here *tn gets automated land patta system the new indian express* - May 04 2023



[ncert books for class 12 biology 2023 download pdf schools](#) - Mar 22 2022

web ncert solutions class 12 physics chemistry maths and biology 2023 24 pdfs are provided here for free download clear your pcmb doubts with ncert solutions class

**ncert solutions for class 12 biology byju s** - Dec 31 2022

web feb 14 2023 from ncert books for class 12 biology chapter 1 till chapter 10 we have enlisted all the pdf links for you in the table below you can download chapter wise pdfs

**ncert books for class 12 biology free pdf download vedantu** - Apr 22 2022

web this sample paper is based on the latest exam pattern and revised syllabus class 12 students must practice it to know the types of objective questions to be asked in the

[ncert books for class 12th biology selfstudys](#) - Jun 24 2022

web biology classes xi xii in the present attempt of the ncert to revise the biology syllabus of the classes xi and xii several documents like learning without burden the

**cbse sample papers for class 12 biology 2023 24 with** - Nov 17 2021

[class 12 biology ncert book apps on google play](#) - Jan 20 2022

**ncert books for class 12 biology pdf download** - Sep 08 2023

web q1 are the ncert books for class 12 biology the best reference guides for the students to prepare well for the board exams students should choose the perfect reference

**textbooks pdf i xii ncert** - Aug 07 2023

web pdf download official prescribed biology class 12 ncert textbook below book based on latest biology class 12 ncert cbse syllabus as on official website cbse

**ecosystem ncert** - Feb 01 2023

web download ncert book for class xii biology table of contents reproduction chapter 1 reproduction in organisms chapter 2 sexual reproduction in flowering

[ncert books class 12 biology testbook com](#) - Nov 29 2022

web sep 1 2023 ncert books for class 12 biology get here updated and download class 12 biology ncert textbooks chapter wise pdf as per cbse syllabus and marking

[ncert books for class 12 biology 2021 22 selfstudys](#) - Oct 29 2022

web access ncert biology books for class 12 and start your studies on selfstudys you can also get many other study material

of ncert class 12 biology join whatsapp for  
*ncert solutions for class 12 biology updated free pdf 2023 24* - Dec 19 2021

**ncert solutions for class 12 download free 2023 24 pdfs** - Oct 17 2021

*biology classes xi xii ncert* - Feb 18 2022

**ncert books for class 12 biology byju s** - Jul 06 2023

web textbook for class xii 12083 biology textbook for class xii first edition december 2006 pausa 1928 reprinted november 2007 january 2009 december 2009

**biology ncert** - Apr 03 2023

web chapter 1 sexual reproduction in flowering plants chapter 2 human reproduction chapter 3 reproductive health chapter 4 principles of inheritance and variation chapter 5

**textbooks pdf i xii ncert** - Oct 09 2023

web welcome to the online textbooks section this online service offers easy access to the ncert textbooks the service covers textbooks of all subjects published by ncert

**ncert books for class 12 pdf free download** - May 24 2022

web concept clarity ncert solutions for class 12 biology offer clear explanations aiding in a solid understanding of complex concepts from genetics to ecology exam readiness

*ncert biology books class 12 11 pdf download* - Mar 02 2023

web the ncert books for class 12 biology pdf are provided here for the students to download and stay ahead in the academic learning it is very handy for the students

ncert books for class 12 biology pdf download - May 04 2023

web biology 14 1 ecosystem structure and function in chapter 13 you have looked at the various components of the environment abiotic and biotic you studied

*best ncert books for biology cbse class 12 2023 exam* - Aug 27 2022

web nov 6 2023 free ncert books download for class 12 biology on vedantu com students can also download the ncert textbooks solutions in pdf for class 12

**ncert book class 12 biology pdf 2023 24 ncert books** - Jun 05 2023

web chapter 20 locomotion and movement chapter 21 neural control and coordination chapter 22 chemical coordination and

integration download ncert biology class

*ncert books for class 12 biology 2023 jagran josh* - Jul 26 2022

web sep 16 2023 ncert books for class 12 biology 2023 national council of educational research and training ncert publishes the ncert class 12 biology books that are

**download ncert book for class xii biology ias exam** - Sep 27 2022

web sep 21 2023 class 12 biology ncert books class 12 ncert english books ncert geography book class 12 ncert class 12 history book class 12 ncert business