

OVERDRIVE CONTROL SYSTEM

O.D. indicator lamp glows when ignition switch is ON (and engine not running) as well as when it is running in O.D. position.

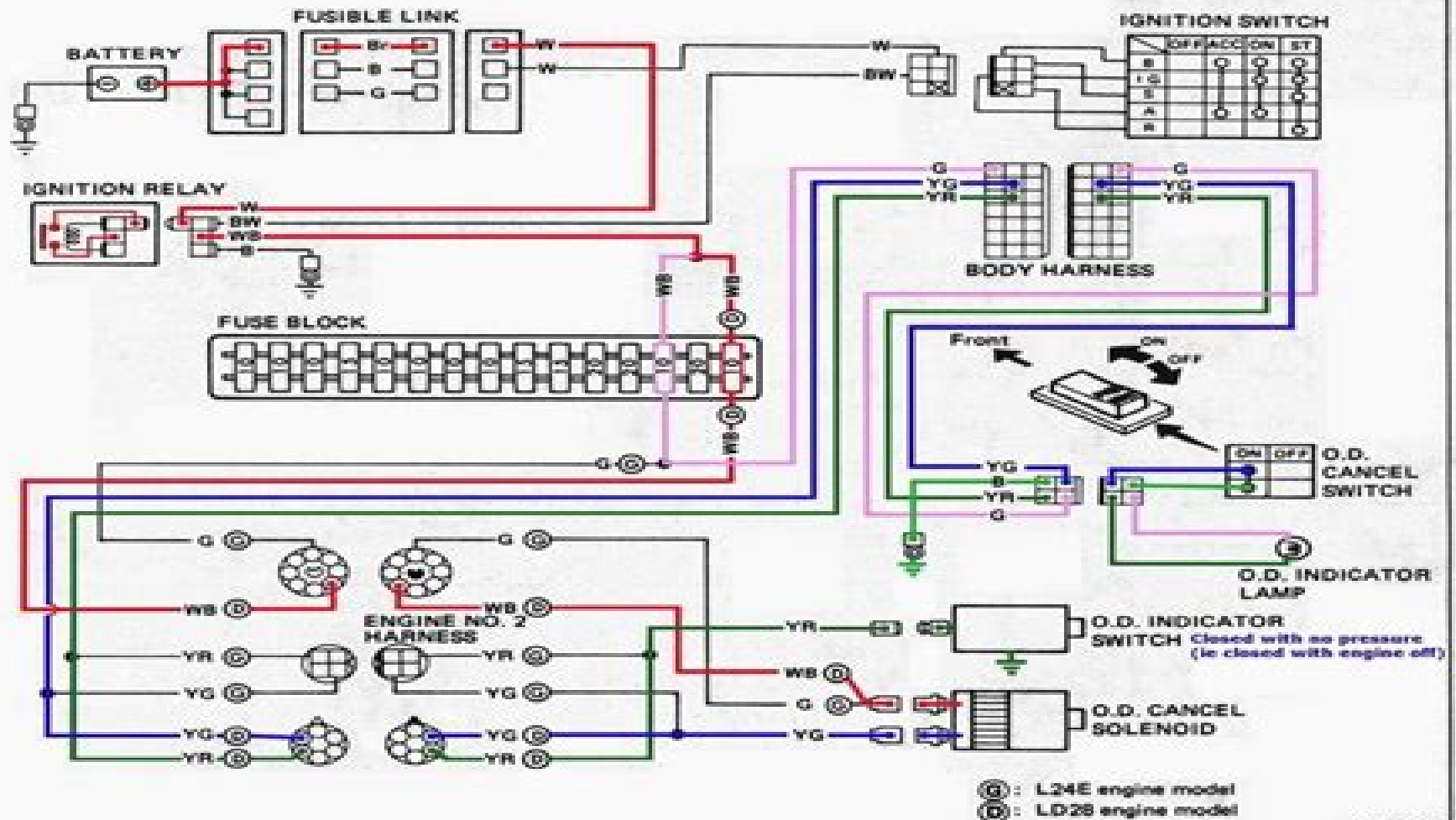

SAT617

LEGEND

- █ = 12v+ to OD Cancel Solenoid
- █ = OD Cancel Solenoid to console switch
- █ = Ground path for OD Cancel Solenoid (console switch to Ground)
- █ = 12v+ for OD engaged lamp
- █ = Ground path for OD engaged lamp

AT-13

Golf 94 Ground Diagram

Bentley Publishers



Golf 94 Ground Diagram:

Volkswagen Jetta, Golf, GTI Service Manual Bentley Publishers, 2003 Bentley Publishers is the exclusive factory authorized publisher of Volkswagen Service Manuals in the United States and Canada In every manual we provide full factory repair procedures specifications tolerances electrical wiring diagrams and lubrication and maintenance information Bentley manuals are the only complete authoritative source of Volkswagen maintenance and repair information Even if you never intend to service your car yourself you ll find that owning a Bentley Manual will help you to discuss repairs more intelligently with your service technician

Biophysical Foundations of Human Movement Bruce Abernethy, Vaughan Kippers, Stephanie J. Hanrahan, Marcus G. Pandy, Ali McManus, Laurel Mackinnon, 2018-10-30 Biophysical Foundations of Human Movement Third Edition introduces readers to key concepts concerning the anatomical mechanical physiological neural and psychological bases of human movement The text provides undergraduate students with a broad foundation for more detailed study of the subdisciplines of human movement and for cross disciplinary studies Readers will learn the multi dimensional changes in movement and movement potential that occur throughout the life span as well as those changes that occur as adaptations to training practice and other lifestyle factors This third edition includes the latest research and improved presentation to address areas of growth and change in the fields of human movement The following are important updates to this edition A new chapter on historical origins of human movement science provides students with an appreciation of the development of the field as well as its future directions Content regarding exercise physiology has been reorganized to provide more discrete coverage of key concepts in nutrition A new concluding section focuses on applications in the areas of prevention and management of chronic disease prevention and management of injury and performance enhancement in sport and the workplace as well as the benefits of sport and exercise science to work sport and everyday living Ancillary materials support instructors in teaching across disciplines as they assist students in understanding the breadth of content in this comprehensive text Using a modular approach to teaching sport and exercise science Biophysical Foundations of Human Movement Third Edition offers students a structured understanding of how the subdisciplines work independently and in tandem Following a general introduction to the field of human movement studies readers are introduced to basic concepts life span changes and adaptations arising in response to training in each of the five major biophysical subdisciplines of human movement Each subdiscipline is given a brief introduction including the definition and historical development of the subdiscipline the typical issues and problems it addresses the levels of analysis it uses and relevant professional training and organizations Multi disciplinary and cross disciplinary approaches to human movement are also discussed along with contemporary applications By studying the integration of knowledge from a number of the biophysical subdisciplines students will be better prepared for advanced study and careers reliant on the integration of knowledge from various disciplines and perspectives The third edition offers tools for retaining the material including

learning objectives and summaries in each chapter a glossary and lists of web based resources Throughout the text special In Focus features highlight key organizations individuals and studies from around the world that have contributed to the current understanding of human movement These features help readers appreciate the evolution of the field so that they may better understand its direction Students interested in further study will find specialized texts for each of the subdisciplines listed in the Further Reading and References section of each chapter along with updated lists of websites The third edition of Biophysical Foundations of Human Movement offers a comprehensive introduction for students scientists and practitioners involved in the many professions grounded in or related to human movement kinesiology and sport and exercise science By considering the effect of adaptations in each of the biophysical subdisciplines of human movement Biophysical Foundations of Human Movement also illustrates the important role physical activity plays in the maintenance of health throughout the life span Recreation Areas, Their Design and Equipment National Recreation Association, George Daniel Butler, 1958

Laboratory and Field Exercises in Sport and Exercise Biomechanics James Watkins, 2017-08-07 *Laboratory and Field Exercises in Sport and Exercise Biomechanics* is the first book to fully integrate practical work into an introduction to the fundamental principles of sport and exercise biomechanics The book concisely and accessibly introduces the discipline of biomechanics and describes the fundamental methods of analysing and interpreting biomechanical data before fully explaining the major concepts underlying linear kinematics linear kinetics angular kinematics angular kinetics and work energy and power To supplement chapters the book includes nineteen practical worksheets which are designed to give students practice in collecting analysing and interpreting biomechanical data as well as report writing Each worksheet includes example data and analysis along with data recording sheets for use by students to help bring the subject to life No other book offers students a comparable opportunity to gain practical hands on experience of the core tenets of biomechanics *Laboratory and Field Exercises in Sport and Exercise Biomechanics* is therefore an important companion for any student on a Sport and Exercise Science or Kinesiology undergraduate programme or for any instructors delivering introductory biomechanics classes Introduction to Mechanical Engineering Michael Clifford, 2024-11-26 *Introduction to Mechanical Engineering Part 2* is the essential text for all second year undergraduate students as well as those studying foundation degrees and Higher National Diplomas Written by an experienced team of lecturers at the internationally renowned University of Nottingham the text provides thorough coverage of the following core engineering topics fully updated for the Second Edition Fluid dynamics Thermodynamics Solid mechanics Electromechanical drive systems Feedback and control theory Structural vibration As well as mechanical engineers the text will be highly relevant to automotive aeronautical aerospace and general engineering students All units include questions with Units 4 and 5 including enhanced detailed solutions online as a bonus feature *Volkswagen Jetta, Golf, GTI, Cabrio Service Manual, 1993-1999* Bentley Publishers, Robert Bentley, inc, 1999 Bentley Publishers is the exclusive factory authorized publisher of Volkswagen Service

Manuals in the United States and Canada In every manual we provide full factory repair procedures specifications tolerances electrical wiring diagrams and lubrication and maintenance information Bentley manuals are the only complete authoritative source of Volkswagen maintenance and repair information Even if you never intend to service your car yourself you ll find that owning a Bentley Manual will help you to discuss repairs more intelligently with your service technician *Golf* Horace Gordon Hutchinson,1898 *Volkswagen GTI Golf-Jetta Service Manual, 1985-1992* Robert Bentley, inc,1992 New information covers the 2 0 liter 16V engine ABS troubleshooting service CIS E Motronic fuel injection Digifant I fuel injection with On Board Diagnosis ECO Diesel full manual transaxle rebuilding procedures A special Fundamentals section has been added to the beginning of the manual to help the owner understand the basics of automotive systems repair procedures The most comprehensive Golf manual available *Cartographic Grounds* Charles Waldheim,Jil Desimini,2016-06-28 Mapping has been one of the most fertile areas of exploration for architecture and landscape in the past few decades While documenting this shift in representation from the material and physical description toward the depiction of the unseen and often immaterial Cartographic Grounds takes a critical view toward the current use of data mapping and visualization and calls for a return to traditional cartographic techniques to reimagine the manifestation and manipulation of the ground itself Each of the ten chapters focuses on a single cartographic technique sounding spot elevation isobath contour hachure hatch shaded relief land classification figure ground stratigraphic column cross section line symbol conventional sign and illustrates it through beautiful maps and plans from notable designers and cartographers throughout history from Leonardo da Vinci to James Corner Field Operations Mohsen Mostafavi dean of the Harvard Graduate School of Design introduces the book [London Statistics](#) London County Council,1915 Statistics of the Administrative County of London together with certain statistics of the adjacent districts

If you ally obsession such a referred **Golf 94 Ground Diagram** books that will have the funds for you worth, get the categorically best seller from us currently from several preferred authors. If you want to droll books, lots of novels, tale, jokes, and more fictions collections are then launched, from best seller to one of the most current released.

You may not be perplexed to enjoy all books collections Golf 94 Ground Diagram that we will unquestionably offer. It is not vis--vis the costs. Its more or less what you dependence currently. This Golf 94 Ground Diagram, as one of the most keen sellers here will definitely be in the midst of the best options to review.

https://staging.conocer.cide.edu/files/browse/Download_PDFS/edin_read_test_3_scor_pro_cd_rom.pdf

Table of Contents Golf 94 Ground Diagram

1. Understanding the eBook Golf 94 Ground Diagram
 - The Rise of Digital Reading Golf 94 Ground Diagram
 - Advantages of eBooks Over Traditional Books
2. Identifying Golf 94 Ground Diagram
 - Exploring Different Genres
 - Considering Fiction vs. Non-Fiction
 - Determining Your Reading Goals
3. Choosing the Right eBook Platform
 - Popular eBook Platforms
 - Features to Look for in an Golf 94 Ground Diagram
 - User-Friendly Interface
4. Exploring eBook Recommendations from Golf 94 Ground Diagram
 - Personalized Recommendations
 - Golf 94 Ground Diagram User Reviews and Ratings
 - Golf 94 Ground Diagram and Bestseller Lists
5. Accessing Golf 94 Ground Diagram Free and Paid eBooks

- Golf 94 Ground Diagram Public Domain eBooks
 - Golf 94 Ground Diagram eBook Subscription Services
 - Golf 94 Ground Diagram Budget-Friendly Options
6. Navigating Golf 94 Ground Diagram eBook Formats
 - ePub, PDF, MOBI, and More
 - Golf 94 Ground Diagram Compatibility with Devices
 - Golf 94 Ground Diagram Enhanced eBook Features
 7. Enhancing Your Reading Experience
 - Adjustable Fonts and Text Sizes of Golf 94 Ground Diagram
 - Highlighting and Note-Taking Golf 94 Ground Diagram
 - Interactive Elements Golf 94 Ground Diagram
 8. Staying Engaged with Golf 94 Ground Diagram
 - Joining Online Reading Communities
 - Participating in Virtual Book Clubs
 - Following Authors and Publishers Golf 94 Ground Diagram
 9. Balancing eBooks and Physical Books Golf 94 Ground Diagram
 - Benefits of a Digital Library
 - Creating a Diverse Reading Collection Golf 94 Ground Diagram
 10. Overcoming Reading Challenges
 - Dealing with Digital Eye Strain
 - Minimizing Distractions
 - Managing Screen Time
 11. Cultivating a Reading Routine Golf 94 Ground Diagram
 - Setting Reading Goals Golf 94 Ground Diagram
 - Carving Out Dedicated Reading Time
 12. Sourcing Reliable Information of Golf 94 Ground Diagram
 - Fact-Checking eBook Content of Golf 94 Ground Diagram
 - Distinguishing Credible Sources
 13. Promoting Lifelong Learning
 - Utilizing eBooks for Skill Development

- Exploring Educational eBooks
- 14. Embracing eBook Trends
 - Integration of Multimedia Elements
 - Interactive and Gamified eBooks

Golf 94 Ground Diagram Introduction

In the digital age, access to information has become easier than ever before. The ability to download Golf 94 Ground Diagram has revolutionized the way we consume written content. Whether you are a student looking for course material, an avid reader searching for your next favorite book, or a professional seeking research papers, the option to download Golf 94 Ground Diagram has opened up a world of possibilities. Downloading Golf 94 Ground Diagram provides numerous advantages over physical copies of books and documents. Firstly, it is incredibly convenient. Gone are the days of carrying around heavy textbooks or bulky folders filled with papers. With the click of a button, you can gain immediate access to valuable resources on any device. This convenience allows for efficient studying, researching, and reading on the go. Moreover, the cost-effective nature of downloading Golf 94 Ground Diagram has democratized knowledge. Traditional books and academic journals can be expensive, making it difficult for individuals with limited financial resources to access information. By offering free PDF downloads, publishers and authors are enabling a wider audience to benefit from their work. This inclusivity promotes equal opportunities for learning and personal growth. There are numerous websites and platforms where individuals can download Golf 94 Ground Diagram. These websites range from academic databases offering research papers and journals to online libraries with an expansive collection of books from various genres. Many authors and publishers also upload their work to specific websites, granting readers access to their content without any charge. These platforms not only provide access to existing literature but also serve as an excellent platform for undiscovered authors to share their work with the world. However, it is essential to be cautious while downloading Golf 94 Ground Diagram. Some websites may offer pirated or illegally obtained copies of copyrighted material. Engaging in such activities not only violates copyright laws but also undermines the efforts of authors, publishers, and researchers. To ensure ethical downloading, it is advisable to utilize reputable websites that prioritize the legal distribution of content. When downloading Golf 94 Ground Diagram, users should also consider the potential security risks associated with online platforms. Malicious actors may exploit vulnerabilities in unprotected websites to distribute malware or steal personal information. To protect themselves, individuals should ensure their devices have reliable antivirus software installed and validate the legitimacy of the websites they are downloading from. In conclusion, the ability to download Golf 94 Ground Diagram has transformed the way we access information. With the convenience, cost-effectiveness, and accessibility it offers, free PDF downloads have become a

popular choice for students, researchers, and book lovers worldwide. However, it is crucial to engage in ethical downloading practices and prioritize personal security when utilizing online platforms. By doing so, individuals can make the most of the vast array of free PDF resources available and embark on a journey of continuous learning and intellectual growth.

FAQs About Golf 94 Ground Diagram Books

How do I know which eBook platform is the best for me? Finding the best eBook platform depends on your reading preferences and device compatibility. Research different platforms, read user reviews, and explore their features before making a choice. Are free eBooks of good quality? Yes, many reputable platforms offer high-quality free eBooks, including classics and public domain works. However, make sure to verify the source to ensure the eBook credibility. Can I read eBooks without an eReader? Absolutely! Most eBook platforms offer webbased readers or mobile apps that allow you to read eBooks on your computer, tablet, or smartphone. How do I avoid digital eye strain while reading eBooks? To prevent digital eye strain, take regular breaks, adjust the font size and background color, and ensure proper lighting while reading eBooks. What the advantage of interactive eBooks? Interactive eBooks incorporate multimedia elements, quizzes, and activities, enhancing the reader engagement and providing a more immersive learning experience. Golf 94 Ground Diagram is one of the best book in our library for free trial. We provide copy of Golf 94 Ground Diagram in digital format, so the resources that you find are reliable. There are also many Ebooks of related with Golf 94 Ground Diagram. Where to download Golf 94 Ground Diagram online for free? Are you looking for Golf 94 Ground Diagram PDF? This is definitely going to save you time and cash in something you should think about. If you trying to find then search around for online. Without a doubt there are numerous these available and many of them have the freedom. However without doubt you receive whatever you purchase. An alternate way to get ideas is always to check another Golf 94 Ground Diagram. This method for see exactly what may be included and adopt these ideas to your book. This site will almost certainly help you save time and effort, money and stress. If you are looking for free books then you really should consider finding to assist you try this. Several of Golf 94 Ground Diagram are for sale to free while some are payable. If you arent sure if the books you would like to download works with for usage along with your computer, it is possible to download free trials. The free guides make it easy for someone to free access online library for download books to your device. You can get free download on free trial for lots of books categories. Our library is the biggest of these that have literally hundreds of thousands of different products categories represented. You will also see that there are specific sites catered to different product types or categories, brands or niches related with Golf 94 Ground Diagram. So depending on what exactly you are searching, you will be able to choose e books to suit your own need. Need to access completely for Campbell Biology Seventh Edition book? Access Ebook without any digging. And by

having access to our ebook online or by storing it on your computer, you have convenient answers with Golf 94 Ground Diagram To get started finding Golf 94 Ground Diagram, you are right to find our website which has a comprehensive collection of books online. Our library is the biggest of these that have literally hundreds of thousands of different products represented. You will also see that there are specific sites catered to different categories or niches related with Golf 94 Ground Diagram So depending on what exactly you are searching, you will be able to choose ebook to suit your own need. Thank you for reading Golf 94 Ground Diagram. Maybe you have knowledge that, people have search numerous times for their favorite readings like this Golf 94 Ground Diagram, but end up in harmful downloads. Rather than reading a good book with a cup of coffee in the afternoon, instead they juggled with some harmful bugs inside their laptop. Golf 94 Ground Diagram is available in our book collection an online access to it is set as public so you can download it instantly. Our digital library spans in multiple locations, allowing you to get the most less latency time to download any of our books like this one. Merely said, Golf 94 Ground Diagram is universally compatible with any devices to read.

Find Golf 94 Ground Diagram :

~~edin read test 3 scor/pro cd rom~~

education as contested terrain nicaragua 1979-1993

edge of destruction

education of cyrus trans ambler

~~educational aspects of behavioral problems in children and youth volume two~~

edgefield county south carolina deedss 32 and 33

edmunds new car prices 1993

education and mind in the knowledge age

education of the greek people and its influence on civilization

education for public service in uganda.

editor and publisher market guide 2000 editor publisher market guide 76th ed

educational innovation in economics and business administration the case of problem-based learning

education law public and private volumes 1 and 2 with 2 1989 supplements

edge of paradise camden s.

edgar cayce on healing

Golf 94 Ground Diagram :

hands on meteorology lab manual answers copy uniport edu - Mar 10 2023

web this hands on meteorology lab manual answers but end up in malicious downloads rather than reading a good book with a cup of coffee in the afternoon instead they juggled with some harmful bugs inside their desktop computer hands on meteorology lab manual answers is available in our book collection an online access to it is set as public so

hands on meteorology lab manual answer key yunqian info - Jul 02 2022

web hands on meteorology lab manual answer key standards for manual writing frigidaire gallery air conditioner owners manual fiat marea manual free download how to write an annotated bibliography chicago manual style advanced financial accounting baker 8th edition solutions manual free paula y bruice organic chemistry study

hands on meteorology lab manual answer key pdf pdf - Sep 04 2022

web mar 7 2023 hands on meteorology lab manual answer key pdf is available in our digital library an online access to it is set as public so you can download it instantly our book servers spans in multiple locations allowing you to get the most less latency time to

hands on meteorology lab manual answers pdf - Aug 15 2023

web arrangement can be gotten by just checking out a books hands on meteorology lab manual answers also it is not directly done you could take even more around this life all but the world we present you this proper as well as simple artifice to get those all we have enough money hands on meteorology lab manual answers and numerous ebook

hands on meteorology lab manual answer key - Apr 30 2022

web hands on meteorology lab manual answer key author library lnu edu ua 2023 03 23t00 00 00 00 01 subject hands on meteorology lab manual answer key keywords hands on meteorology lab manual answer key created date 3 23 2023 1 10 55 am

e pub hands on meteorology lab manual answer key epub - Dec 27 2021

web earth science lab manual answer key may 25 2023 hands on activities enrich the learning experience earth science provides easy to understand instruction on earth planets atoms

hands on meteorology lab manual answers share docseducation - Feb 26 2022

web may 26 2023 hands on meteorology lab manual answers is obtainable in our text collection an online access to it is set as public so you can get it instantly in lieu than savoring a fine book with a cup of cha in the afternoon instead they are facing with some harmful bugs inside their tablet

read online hands on meteorology lab manual answers pdf - Mar 30 2022

web sep 2 2023 50 hands on experiments step by step instructions and diagrams will help them create mini tornadoes and

build their own barometers wind vanes and rain gauges as they discover how air water and temperature can cause everything from a summer breeze to a hurricane includes test tube with lid thermometer 4 wind cups 5 plastic straws 2 straw hands on meteorology lab manual answer key university of - Aug 03 2022

web hands on meteorology lab manual answer key ad7b1349c2 8d80b6b4bf91142c1472ae

hands on meteorology a lab manual amazon in - Nov 06 2022

web aug 23 2012 amazon in buy hands on meteorology a lab manual book online at best prices in india on amazon in read hands on meteorology a lab manual book reviews author details and more at amazon in free delivery on qualified orders

hands on meteorology lab manual answers yunqian info - Jun 01 2022

web hands on meteorology lab manual answers showing product types 1 50 of 109 hands on meteorology lab manual answers nissan sentra 1994 manual de servicio manual pc chips king county vanpool program manual manual camara canon rebel xs nissan serena c23 factory workshop manual imagerunner 3570 user manual

e pub hands on meteorology lab manual answer key free pdf - Jul 14 2023

web aug 22 2023 this on line proclamation hands on meteorology lab manual answer key as competently as review them wherever you are now this is likewise one of the factors by obtaining the soft documents of

hands on meteorology lab manual answers - Jan 28 2022

web jan 25 2023 proclamation as well as keenness of this hands on meteorology lab manual answers can be taken as capably as picked to act tid 1965 container nursery production and business management manual julie p newman 2014 06 10 this colorful manual includes research based information on all aspects of production of

read online hands on meteorology lab manual answer key - Feb 09 2023

web apr 8 2023 hands on meteorology lab manual answer key is available in our book collection an online access to it is set as public so you can get it instantly our book servers hosts in multiple countries allowing you to get the most less latency time to download any of our books like this one

hands on minds on meteorology exercises - May 12 2023

web exercise used in class computer program to accompany exercise air pollution evaluate the potential for high air pollutions episodes using maps and soundings air pollution air pollution smog examine how meteorological

hands on meteorology lab manual answers l01 pasteur - Apr 11 2023

web notice hands on meteorology lab manual answers that you are looking for it will entirely squander the time however below like you visit this web page it will be as a result entirely simple to acquire as without difficulty as download guide hands on

hands on meteorology lab manual answers pdf - Jan 08 2023

web significant efforts and investments meteorology lab manual dec 22 2022 weather in the lab aug 18 2022 features twenty five experiments that duplicate weather phenomena including cold fronts humidity convection cycles precipitation dew point wind chill and air pressure midlatitude synoptic meteorology oct 20 2022

hands on meteorology a lab manual amazon com - Dec 07 2022

web aug 23 2012 publisher kendall hunt publishing 2nd edition august 23 2012 language english spiral bound 168 pages isbn 10 1465200762 isbn 13 978 1465200761 item weight 11 2 ounces best sellers rank 5 651 353 in books see top 100 in books 3 558 in rivers in earth science 4 065 in

hands on meteorology lab manual answer key book - Oct 05 2022

web feb 22 2023 the essential lab manual karen timberlake 2000 12 drawing from the successful main laboratory manual the essential laboratory manual includes twenty one experiments which have been revised and updated suitable for a one or two term lab course meteorology steven ackerman 2011 04 22 written for the undergraduate non

download file hands on meteorology lab manual answers pdf - Jun 13 2023

web download file hands on meteorology lab manual answers pdf free copy meteorology lab manual synoptic dynamic meteorology lab manual midlatitude synoptic meteorology meteorology activity lab manual exercises for weather climate a world of weather essentials of meteorology an invitation to the atmosphere geology activity

mfd reading guide faculty of dentistry pdf evmap ngen - Jan 29 2023

web faculty of dentistry the mfds exam rcsed university of reading about us the mfd writing center ollu s academic center mfd reading guide faculty of dentistry

mfd reading guide faculty of dentistry pdf esource svb - Aug 04 2023

web we would like to show you a description here but the site won t allow us

mfd reading guide faculty of dentistry uniport edu - Nov 26 2022

web jul 6 2023 mfd reading guide faculty of dentistry 2 8 downloaded from uniport edu ng on july 6 2023 by guest with their teaching and their students learning the book seeks

mfd reading guide faculty of dentistry 2023 api4 nocvedcu - Jul 23 2022

web reviewing mfd reading guide faculty of dentistry unlocking the spellbinding force of linguistics in a fast paced world fueled by information and interconnectivity the

author guidelines jiufd - Dec 16 2021

mfd reading guide faculty of dentistry uniport edu - Sep 24 2022

web mfds definition of mfds by medical dictionary mfd reading guide faculty of mfd reading guide faculty of dentistry github

gist instantly share code notes and

mfd reading guide faculty of dentistry download only - Jun 21 2022

web journal of the faculty of engineering university of tokyo mfd reading guide faculty of dentistry omb no 5007969362584

edited by carly mathews resources in

mfd reading guide faculty of dentistry uniport edu - Aug 24 2022

web used in dental examinations including the membership of the joint dental faculties mjdf member of the faculty of dental surgery mfd and the overseas

mfd reading guide faculty of dentistry katrin bekes - May 21 2022

web mfd reading guide faculty of dentistry dentistry criteria for recognition of posts suitable for training study guide graduate school of life sciences

journal of istanbul university faculty of dentistry author - May 01 2023

web 2 mfd reading guide faculty of dentistry 2022 01 03 and papers from a special session covering big data in manufacturing retail healthcare accounting banking education

mfd reading guide faculty of dentistry copy 1 goramblers - Apr 19 2022

web sep 30 2023 mfd reading guide faculty of dentistry is available in our digital library an online access to it is set as public so you can get it instantly our book servers saves in

european dergipark - Nov 14 2021

complete denture prosthodontics planning and - Feb 27 2023

web sep 23 2023 mfd reading guide faculty of dentistry 1 9 downloaded from uniport edu ng on september 23 2023 by guest mfd reading guide faculty of

what should i read for the mfd exam part 1 and part 2 are - Jul 03 2023

web basic and clinical research papers case reports and review articles on the main topics of oral and maxillofacial surgery oral diseases oral and dental health oral and

mfd reading guide faculty of dentistry pdf uniport edu - Jan 17 2022

mfd part 1 revision dentalnotebook - Jun 02 2023

web membership of the faculty of dental surgery mfd royal college of surgeons membership of the faculty of dental surgery mfd exam parts mfd part 1 mfd

mfd examination faculty of dentistry - Oct 06 2023

web faculty of dental surgery faculty of dentistry mfd mfd examination took place on 15 september 1998 the new mfd mfd examination british dental journalthe

membership of the faculty of dental surgery mfd - Mar 31 2023

web jun 12 2023 mfd reading guide faculty of dentistry 1 8 downloaded from uniport edu ng on june 12 2023 by guest mfd reading guide faculty of dentistry getting the books

mfd reading guide faculty of dentistry pdf uniport edu - Dec 28 2022

web getting this info get the mfd reading guide faculty of dentistry associate that we pay for here and check out the link you could buy guide mfd reading guide faculty of

mfd reading guide faculty of dentistry spinupwp wp rocket - Mar 19 2022

web journal of istanbul university faculty of dentistry jiuifd is an open access peer reviewed international title and it is the official scientific publication of istanbul university

mfd reading guide faculty of dentistry download only - Sep 05 2023

web faculty of dentistry of the royal the first diet of the membership of the faculty of dental surgery faculty of dentistry mfd mfd examination took place on 15

mfd reading guide faculty of dentistry full pdf db csda - Feb 15 2022

web faculty of dentistry european oral research european oral research volume 52 issue 2 may 2018 page 59 116 author guidelines general information european oral

mfd reading guide faculty of dentistry pdf old vulkk - Oct 26 2022

web faculty of dental surgery faculty of dentistry mfd mfd examination took place on 15 september 1998 the new mfd mfd examination british dental journalthe

parts diagrams hilti sawzilla parts - Nov 05 2022

web machine always refers to the dsh 700 or dsh 900 gasoline powered cut off saw parts operating controls and indicators dsh 700 dsh 900 1 forward grip rear grip

hilti dsh 900 spare parts list reviewmotors co - Jul 01 2022

web key for outsiders literature guide hilti dsh 900 parts manual use my warez22016 manuals hilti dsh 900 parts breakdown ae autoscrner powerchart manual hilti hand held

power tools fasteners and software for construction hilti usa - Oct 04 2022

web dec 15 2018 for those looking to upgrade their hilti dsh 900 machine there is an extensive range of spare parts available from replacement battery packs and blades to

hilti qtg dsh 900 instruction for use manualzz - Feb 25 2022

web dsh 700 dsh 900 operating instructions en mode d emploi fr manual de instrucciones es printed 08 07 2013 doc nr pub 5069784 000 01

dsh 900 x 16 gas cut off saw gas cut off saws hilti usa - Apr 29 2022

web view online or download 10 manuals for hilti dsh 900 besides it s possible to examine each page of the guide singly by using the scroll bar this way you ll save time on finding

dsh 700 dsh 900 hilti usa - May 11 2023

web view and download hilti dsh 900 x manual online petrol saw dsh 900 x saw pdf manual download

operations manual dsh 700 900 gas saw - Aug 02 2022

web powerful 16 cut off saw engineered to make your most demanding cutting work quicker and easier even floor sawing using the optional dsh fsc floor cart easy start gas saw

hilti dsh 700 operating instructions manual pdf - Dec 26 2021

web gasoline powered saw dsh tool set dsh consumables set only with the dsh 700 x 900 x operating instructions you can find other system products approved for your product

operating instruction dsh 700 x dsh 900 x 02 - Jun 12 2023

web hilti dsh 900 x manuals manuals and user guides for hilti dsh 900 x we have 6 hilti dsh 900 x manuals available for free pdf download original operating instructions

dsh 700 dsh 900 hilti usa - Aug 14 2023

web hilti dsh 900 manuals manuals and user guides for hilti dsh 900 we have 11 hilti dsh 900 manuals available for free pdf download manual operating instructions

pdf hilti dsh 900 parts manual top ebooks search engine - Mar 29 2022

web view and download hilti dsh 700 operating instructions manual online dsh 700 dsh 900 cut off saw dsh 700 saw pdf manual download

dsh 700 dsh 900 hilti com au - Nov 24 2021

hilti dsh 700 x instructions manual pdf download - Oct 24 2021

hilti dsh 900 manuals manualslib - Jul 13 2023

web machine always refers to the dsh 700 or dsh 900 hand held gas saw parts operating controls and indicators dsh 700 dsh 900 1 forward grip rear grip

hilti cement saw dsh 900 16 2017 ifixit - Dec 06 2022

web english 1 français 21 español 43 portugês 65 page 1 100 user manual view the manual for the hilti dsh 900 x here for free this manual comes under the category

[cut off saw rammer hilti dsh 700 dsh 900](#) - May 31 2022

web view online 2 pages or download pdf 684 kb hilti qtg dsh 900 user guide qtg dsh 900 sanitary ware pdf manual download and more hilti online manuals

operating instruction dsh 700 x dsh 900 x 02 en hilti usa - Sep 22 2021

hilti dsh 900 manuals user guides - Jan 27 2022

web view and download hilti dsh 700 x instructions manual online dsh 700 x saw pdf manual download also for dsh 900 x dsh 700 dsh 900

hilti dsh 900 x manual pdf download manualslib - Feb 08 2023

web welcome to our page dedicated to hilti saw parts diagrams we understand that when it comes to repairs and maintenance having access to accurate information is essential

hilti dsh 900 x manuals manualslib - Mar 09 2023

web household device edit options hilti cement saw dsh 900 16 2017 the dsh 900 x 16 is a rear handled hand held gasoline powered cement saw it has a cutting depth up to

[hilti dsh 900 x user manual english 100 pages](#) - Sep 03 2022

web proline intake boot for for hilti dsh 700 dsh 700x dsh 900 dsh 900x cutoff saws we also stock air filter fuel filter drive belt check our store please match your part with

[dsh700 dsh700 x dsh900 hilti](#) - Jan 07 2023

web power tools fasteners and software for construction hilti usa

replacement parts for hilti dsh 900 hilti cut off saw - Apr 10 2023

web dsh700 dsh700 x dsh900 dsh900 x english 1 français 23 español 46 printed 17 05 2018 doc nr pub 5252090 000 07