

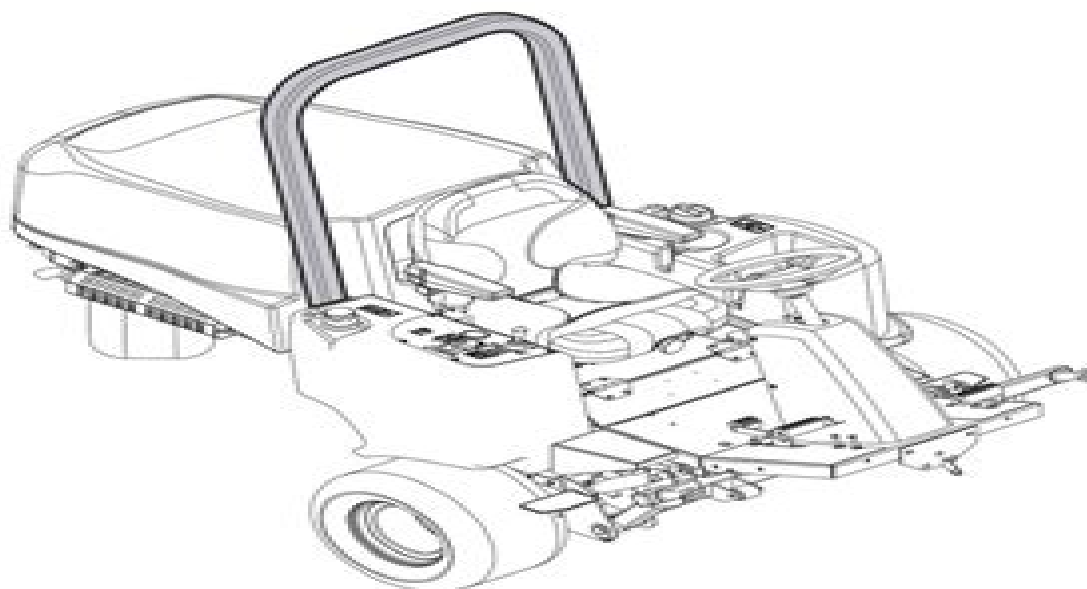

**INSTALLATION INSTRUCTIONS
MODE D'EMPLOI
INSTALLATIE-INSTRUCTIES
MONTAGEANLEITUNG
ISTRUZIONI PER L'INSTALLAZIONE
INSTALLATIONSVEJLEDNING
INSTALLATIONSANVISNINGAR
ASENNUSOHJEET
INSTRUCCIONES DE INSTALACION
INSTRUÇÕES DE MONTAGEM**

JACOBSEN[®] AR3 / TR3 - TOPS Frame Kit LMAC164



GB
English

FR
French

NL
Dutch

DE
German

IT
Italian

DK
Danish

SE
Swedish

FI
Finnish

ES
Spanish

PT
Portuguese

Jacobsen Ar3 Manual

R Sandford



Jacobsen Ar3 Manual:

Discover tales of courage and bravery in Explore Bravery with is empowering ebook, Unleash Courage in **Jacobsen Ar3 Manual** . In a downloadable PDF format (*), this collection inspires and motivates. Download now to witness the indomitable spirit of those who dared to be brave.

https://staging.conocer.cide.edu/book/book-search/Download_PDFS/goldbugs%20and%20greenbacks%20the%20antimonopoly%20tradition%20and%20the%20politics%20of%20finance%20in%20america%201865%201896.pdf

Table of Contents Jacobsen Ar3 Manual

1. Understanding the eBook Jacobsen Ar3 Manual
 - The Rise of Digital Reading Jacobsen Ar3 Manual
 - Advantages of eBooks Over Traditional Books
2. Identifying Jacobsen Ar3 Manual
 - Exploring Different Genres
 - Considering Fiction vs. Non-Fiction
 - Determining Your Reading Goals
3. Choosing the Right eBook Platform
 - Popular eBook Platforms
 - Features to Look for in an Jacobsen Ar3 Manual
 - User-Friendly Interface
4. Exploring eBook Recommendations from Jacobsen Ar3 Manual
 - Personalized Recommendations
 - Jacobsen Ar3 Manual User Reviews and Ratings
 - Jacobsen Ar3 Manual and Bestseller Lists
5. Accessing Jacobsen Ar3 Manual Free and Paid eBooks
 - Jacobsen Ar3 Manual Public Domain eBooks
 - Jacobsen Ar3 Manual eBook Subscription Services
 - Jacobsen Ar3 Manual Budget-Friendly Options

6. Navigating Jacobsen Ar3 Manual eBook Formats
 - ePub, PDF, MOBI, and More
 - Jacobsen Ar3 Manual Compatibility with Devices
 - Jacobsen Ar3 Manual Enhanced eBook Features
7. Enhancing Your Reading Experience
 - Adjustable Fonts and Text Sizes of Jacobsen Ar3 Manual
 - Highlighting and Note-Taking Jacobsen Ar3 Manual
 - Interactive Elements Jacobsen Ar3 Manual
8. Staying Engaged with Jacobsen Ar3 Manual
 - Joining Online Reading Communities
 - Participating in Virtual Book Clubs
 - Following Authors and Publishers Jacobsen Ar3 Manual
9. Balancing eBooks and Physical Books Jacobsen Ar3 Manual
 - Benefits of a Digital Library
 - Creating a Diverse Reading Collection Jacobsen Ar3 Manual
10. Overcoming Reading Challenges
 - Dealing with Digital Eye Strain
 - Minimizing Distractions
 - Managing Screen Time
11. Cultivating a Reading Routine Jacobsen Ar3 Manual
 - Setting Reading Goals Jacobsen Ar3 Manual
 - Carving Out Dedicated Reading Time
12. Sourcing Reliable Information of Jacobsen Ar3 Manual
 - Fact-Checking eBook Content of Jacobsen Ar3 Manual
 - Distinguishing Credible Sources
13. Promoting Lifelong Learning
 - Utilizing eBooks for Skill Development
 - Exploring Educational eBooks
14. Embracing eBook Trends
 - Integration of Multimedia Elements

-
- Interactive and Gamified eBooks

Jacobsen Ar3 Manual Introduction

In today's digital age, the availability of Jacobsen Ar3 Manual books and manuals for download has revolutionized the way we access information. Gone are the days of physically flipping through pages and carrying heavy textbooks or manuals. With just a few clicks, we can now access a wealth of knowledge from the comfort of our own homes or on the go. This article will explore the advantages of Jacobsen Ar3 Manual books and manuals for download, along with some popular platforms that offer these resources. One of the significant advantages of Jacobsen Ar3 Manual books and manuals for download is the cost-saving aspect. Traditional books and manuals can be costly, especially if you need to purchase several of them for educational or professional purposes. By accessing Jacobsen Ar3 Manual versions, you eliminate the need to spend money on physical copies. This not only saves you money but also reduces the environmental impact associated with book production and transportation. Furthermore, Jacobsen Ar3 Manual books and manuals for download are incredibly convenient. With just a computer or smartphone and an internet connection, you can access a vast library of resources on any subject imaginable. Whether you're a student looking for textbooks, a professional seeking industry-specific manuals, or someone interested in self-improvement, these digital resources provide an efficient and accessible means of acquiring knowledge. Moreover, PDF books and manuals offer a range of benefits compared to other digital formats. PDF files are designed to retain their formatting regardless of the device used to open them. This ensures that the content appears exactly as intended by the author, with no loss of formatting or missing graphics. Additionally, PDF files can be easily annotated, bookmarked, and searched for specific terms, making them highly practical for studying or referencing. When it comes to accessing Jacobsen Ar3 Manual books and manuals, several platforms offer an extensive collection of resources. One such platform is Project Gutenberg, a nonprofit organization that provides over 60,000 free eBooks. These books are primarily in the public domain, meaning they can be freely distributed and downloaded. Project Gutenberg offers a wide range of classic literature, making it an excellent resource for literature enthusiasts. Another popular platform for Jacobsen Ar3 Manual books and manuals is Open Library. Open Library is an initiative of the Internet Archive, a non-profit organization dedicated to digitizing cultural artifacts and making them accessible to the public. Open Library hosts millions of books, including both public domain works and contemporary titles. It also allows users to borrow digital copies of certain books for a limited period, similar to a library lending system. Additionally, many universities and educational institutions have their own digital libraries that provide free access to PDF books and manuals. These libraries often offer academic texts, research papers, and technical manuals, making them invaluable resources for students and researchers. Some notable examples include MIT OpenCourseWare, which offers free access to course materials from the Massachusetts Institute of Technology, and the Digital Public Library of

America, which provides a vast collection of digitized books and historical documents. In conclusion, Jacobsen Ar3 Manual books and manuals for download have transformed the way we access information. They provide a cost-effective and convenient means of acquiring knowledge, offering the ability to access a vast library of resources at our fingertips. With platforms like Project Gutenberg, Open Library, and various digital libraries offered by educational institutions, we have access to an ever-expanding collection of books and manuals. Whether for educational, professional, or personal purposes, these digital resources serve as valuable tools for continuous learning and self-improvement. So why not take advantage of the vast world of Jacobsen Ar3 Manual books and manuals for download and embark on your journey of knowledge?

FAQs About Jacobsen Ar3 Manual Books

How do I know which eBook platform is the best for me? Finding the best eBook platform depends on your reading preferences and device compatibility. Research different platforms, read user reviews, and explore their features before making a choice. Are free eBooks of good quality? Yes, many reputable platforms offer high-quality free eBooks, including classics and public domain works. However, make sure to verify the source to ensure the eBook credibility. Can I read eBooks without an eReader? Absolutely! Most eBook platforms offer webbased readers or mobile apps that allow you to read eBooks on your computer, tablet, or smartphone. How do I avoid digital eye strain while reading eBooks? To prevent digital eye strain, take regular breaks, adjust the font size and background color, and ensure proper lighting while reading eBooks. What the advantage of interactive eBooks? Interactive eBooks incorporate multimedia elements, quizzes, and activities, enhancing the reader engagement and providing a more immersive learning experience. Jacobsen Ar3 Manual is one of the best book in our library for free trial. We provide copy of Jacobsen Ar3 Manual in digital format, so the resources that you find are reliable. There are also many Ebooks of related with Jacobsen Ar3 Manual. Where to download Jacobsen Ar3 Manual online for free? Are you looking for Jacobsen Ar3 Manual PDF? This is definitely going to save you time and cash in something you should think about. If you trying to find then search around for online. Without a doubt there are numerous these available and many of them have the freedom. However without doubt you receive whatever you purchase. An alternate way to get ideas is always to check another Jacobsen Ar3 Manual. This method for see exactly what may be included and adopt these ideas to your book. This site will almost certainly help you save time and effort, money and stress. If you are looking for free books then you really should consider finding to assist you try this. Several of Jacobsen Ar3 Manual are for sale to free while some are payable. If you arent sure if the books you would like to download works with for usage along with your computer, it is possible to download free trials. The free guides make it easy for someone to free access online library for download books to your device. You can get free download on free trial for lots of books categories. Our library is the

biggest of these that have literally hundreds of thousands of different products categories represented. You will also see that there are specific sites catered to different product types or categories, brands or niches related with Jacobsen Ar3 Manual. So depending on what exactly you are searching, you will be able to choose e books to suit your own need. Need to access completely for Campbell Biology Seventh Edition book? Access Ebook without any digging. And by having access to our ebook online or by storing it on your computer, you have convenient answers with Jacobsen Ar3 Manual To get started finding Jacobsen Ar3 Manual, you are right to find our website which has a comprehensive collection of books online. Our library is the biggest of these that have literally hundreds of thousands of different products represented. You will also see that there are specific sites catered to different categories or niches related with Jacobsen Ar3 Manual So depending on what exactly you are searching, you will be able to choose ebook to suit your own need. Thank you for reading Jacobsen Ar3 Manual. Maybe you have knowledge that, people have search numerous times for their favorite readings like this Jacobsen Ar3 Manual, but end up in harmful downloads. Rather than reading a good book with a cup of coffee in the afternoon, instead they juggled with some harmful bugs inside their laptop. Jacobsen Ar3 Manual is available in our book collection an online access to it is set as public so you can download it instantly. Our digital library spans in multiple locations, allowing you to get the most less latency time to download any of our books like this one. Merely said, Jacobsen Ar3 Manual is universally compatible with any devices to read.

Find Jacobsen Ar3 Manual :

goldbugs and greenbacks the antimonopoly tradition and the politics of finance in america 1865-1896

golden age of wrestling vol 2

golfers repair and maintenance handbook

going out of our minds

gone crazy and back again

golubaia orda viixiii vek istoricheskii roman

golfing greats two top pros

good faith & truthful ignorance - a case of trans-atlantic bigamy

goldenrod and dayflowers

gold counselling a structured psychotherapeutic approach to the mapping and realigning of belief systems

gone tomorrow a bill slider mystery

golem methuselah and shylock the plays by edward einhorn

golden on taormina

golf its just a game

gold and gods of peru

Jacobsen Ar3 Manual :

basic structural analysis c s reddy solutions download now - May 30 2022

web eeng ali6515 basic structural analysis c s reddy solutions pdf free download as pdf file pdf text file txt or read online for free

basic structural analysis c s reddy google books - Aug 13 2023

web basic structural analysis c s reddy tata mcgraw hill 2011 structural analysis engineering 841 pages the new edition of this book presents the basic principles of classical

basic structural analysis reddy c s 9780070965676 - Feb 07 2023

web jun 1 1982 basic structural analysis paperback june 1 1982 by c s reddy author

[basic structural analysis textbook by c s reddy free download](#) - Dec 05 2022

web basic structural analysis textbook by c s reddy free download pdf the new edition of this book presents the basic principles of classical and matrix structural analysis it provides a smooth transition from the classical approaches that are based on physical behavior of structures in terms of their deflected shapes to a formal treatment of

basic structural analysis by c s reddy academia edu - Oct 15 2023

web structural behavior of outriggers lateral system for high rise building over 30 floors have been investigated the study gives guidelines for the efficiency of the system for each specific building configuration

basic structural analysis c s reddy google search pdf - Nov 04 2022

web basic structural analysis c s reddy google search pdf free download as pdf file pdf text file txt or read online for free

[basic structural analysis by c s reddy pdf structural analysis](#) - Aug 01 2022

web fstructural analysis wikipedia the free encyclopedia structural analysis is the determination of the effects of loads on physical structures and their components structures subject to this type of analysis include all pdf of basic structural analysis c s reddy suggestions check your spelling try less or different keywords

basic structural analysis c s reddy mcgraw hill - Feb 24 2022

web both print ebook 75 print version the estimated delivery date of the print version is approximately 3 to 5 working days from the date of placing the order ebooks no physical copy will be delivered the books offered through this platform are designed to be read only through web browser or ebook reader apps ebooks this book has been already added

[ebook basic structural analysis by c s reddy](#) - Mar 28 2022

web basic structural analysis by c s reddy spatial patterns of phytodiversity assessing vegetation using dis similarity measures mar 21 2021 catalogue on multilocation evaluation of rice germplasm jun 11 2020 the changing scenario in plant sciences oct 16 2020 genetic engineering and in vitro culture of crop legumes sep 14 2020

basic structural analysis c s reddy pdf pdf scribd - Oct 03 2022

web basic structural analysis c s reddy pdf by easyengineering net pdf free ebook download as pdf file pdf text file txt or view presentation slides online

basic structural analysis reddy google books - Apr 09 2023

web it provides a smooth transition from the classical approaches that are based on physical behaviour of structures in terms of their deflected shapes to a formal treatment of a general class of structures by means of matrix formulation in order to understand how the structural problems can be formulated in order to make them suitable for computer

basic structural analysis semantic scholar - Jun 30 2022

web basic structural analysis inproceedings reddy1982basicsa title basic structural analysis author chandra shekhar k reddy year 1982 url api semantic scholar org corpusid 137059617 c s reddy published 1 june 1982 materials science

basic structural analysis cs reddy 3rd edition paperback - Jan 06 2023

web amazon in buy basic structural analysis cs reddy 3rd edition book online at best prices in india on amazon in read basic structural analysis cs reddy 3rd edition book reviews author details and more at amazon in free delivery on qualified orders

basic structural analysis c s reddy pdf 5wggkdelmzw7 - Sep 02 2022

web basic structural analysis c s reddy pdf uploaded by andres perez cruz 0 0 january 2021 pdf bookmark embed this document was uploaded by user and they confirmed that they have the permission to share it

download basic structural analysis c s reddy pdf - Apr 28 2022

web download basic structural analysis c s reddy pdf type pdf txt date january 2020 size 130 9mb author andres perez cruz this document was uploaded by user and they confirmed that they have the permission to share it if you are author or own the copyright of this book please report to us by using this dmca report form report dmca

pdf basic structural analysis c s reddy pdf free download - Sep 14 2023

web download pdf report this file description download basic structural analysis c s reddy pdf free in pdf format download basic structural analysis c s reddy pdf

basic structural analysis 3rd edn reddy c s - May 10 2023

web 10 days from delivery replacement the new edition of this book presents the basic principles of classical and matrix structural analysis it provides a smooth transition from the classical approaches that are based on physical behaviour of structures in terms of their deflected shapes to a formal treatment of a general class of structures by

basic structural analysis c s reddy pdf pdf scribd - Jun 11 2023

web basic structural analysis c s reddy pdf free ebook download as pdf file pdf or view presentation slides online

basic structural analysis si units c s reddy google books - Mar 08 2023

web basic structural analysis si units author c s reddy publisher tata mcgraw hill 1981 isbn 0070965676 9780070965676

length 594 pages export citation bibtex endnote refman

basic structural analysis reddy google books - Jul 12 2023

web basic structural analysis reddy google books overview the new edition of this book presents the basic principles of classical and matrix structural analysis it provides a smooth

grand livre des perles de cristal le livre pas cher patricia - Jul 22 2023

nov 10 2005 ce beau livre met à l honneur les perles de cristal et vous en révèle tous les secrets réalisez parmi plus de 70 modèles originaux et personnalisés les bijoux qui siéront

le grand livre des perles de cristal patricia ponce - Jun 21 2023

nov 10 2005 grand livre des perles de cristal le ponce patricia on amazon com free shipping on qualifying offers grand livre des perles de

grand livre des perles de cristal le livre d occasion - Feb 05 2022

dec 6 2005 select the department you want to search in

grand livre des perles de cristal le cartonné fnac - Sep 24 2023

nov 10 2005 voir tout ce grand livre rassemble tous les secrets des techniques d enfilage et de conception des bijoux en perles de cristal pour le plus grand bonheur des expertes

grand livre des perles de cristal le hardcover - May 20 2023

ce grand livre rassemble tous les secrets des techniques d enfilage et de conception des bijoux en perles de cristal pour le plus grand bonheur des expertes comme des débutantes il

le cristal paris 6 avenue de la grande armee - Nov 02 2021

le grand livre des perles de cristal patricia ponce - Oct 13 2022

buy grand livre des perles de cristal le by ponce patricia isbn 9782215077893 from amazon s book store everyday low prices and free delivery on eligible orders

le grand livre des perles de cristal amazon ca - Mar 18 2023

grand livre des perles de cristal le patricia ponce fleurus des milliers de livres avec la livraison chez vous en 1 jour ou en magasin avec 5 de réduction

grand livre des perles de cristal le abebooks - Jan 16 2023

découvrez et achetez le livre le grand livre des perles de cristal écrit par patricia ducerf chez fleurs sur lalibrairie com

grand livre des perles de cristal le amazon de - Jul 10 2022

retrouvez le grand livre des perles de cristal french edition by patricia ponce 2005 12 07 et des millions de livres en stock sur amazon fr achetez neuf ou d occasion 2005 12 07

grand livre des perles de cristal le par ponce patricia - Mar 06 2022

auteur ponce patricia isbn 9782215077893 Édition mango livraison gratuite expédiée en 24h satisfait ou remboursé

grand livre des perles de cristal le goodreads - Apr 19 2023

le grand livre des perles de cristal ponce patricia amazon ca livres aller au contenu principal ca bonjour entrez sélectionnez le service dans lequel vous souhaitez effectuer

grand livre des perles de cristal le gebundene - Aug 11 2022

grand livre des perles de cristal le ponce patricia hélye lebaron catherine renard patrice amazon de books

grand livre des perles de cristal le patricia ponce acheter - May 08 2022

toutes les recommandations de lecture à découvrir grand livre des perles de cristal de patricia ponce fermer accueil mes livres ajouter des livres le grand livre

amazon fr le grand livre des perles de cristal french edition - Jun 09 2022

nov 10 2005 ce beau livre met à l honneur les perles de cristal et vous en révèle tous les secrets réalisez parmi plus de 70 modèles originaux et personnali frais de port à 0 01

grand livre des perles de cristal le hardcover 10 - Sep 12 2022

grand livre des perles de cristal le ponce patricia hélye lebaron catherine renard patrice isbn 9782215077893 kostenloser versand für alle bücher mit versand

le grand livre des perles de cristal hardcover dec 6 2005 - Jan 04 2022

grand livre des perles de cristal le art et technique ponce patricia amazon es libros

que lire après grand livre des perles de cristal babelio - Apr 07 2022

heures d ouverture activités en magasin coordonnées du services aux institutions english panier 99 rechercher select recherche avancée accueil livres arts

le grand livre des perles de cristal librairie eyrolles - Nov 14 2022

nov 11 2005 le grand livre des perles de cristal de plongez vous dans le livre patricia ponce au format ajoutez le à votre liste de souhaits ou abonnez vous à l auteur patricia

grand livre des perles de cristal le amazon fr - Aug 23 2023

grand livre des perles de cristal le ponce patricia amazon fr livres passer au contenu principal fr bonjour entrez votre adresse livres sélectionnez la section dans

grand livre des perles de cristal le cartonné patricia ponce - Feb 17 2023

grand livre des perles de cristal le de ponce patricia sur abebooks fr isbn 10 2215077891 isbn 13 9782215077893 mango 2005 couverture rigide

grand livre des perles de cristal le art et - Dec 03 2021

le grand livre des perles de cristal lalibrairie com - Dec 15 2022

nov 10 2005 isbn13 978 2 215 07789 3 ce grand livre rassemble tous les secrets des techniques d enfilage et de conception des bijoux en perles de cristal pour le plus grand

historias de spider man leo con marvel nivel 3 la pdf mkt - Jul 01 2022

web historias de spider man leo con marvel nivel 3 la downloaded from mkt canadaintercambio com by guest carpenter danika marvel saga el

impresiones del juego spider man 2 ps5 te sentirás como - Apr 29 2022

web 3 hours ago spider man 2 no es sólo un gran juego de spider man también es un juego decente de superman io9 jugó varias horas del muy esperado juego de playstation 5

historias de spider man leo con marvel nivel 3 la - Apr 10 2023

web 2 historias de spider man leo con marvel nivel 3 la 2023 02 27 new ways to die spider man encounters new threats as his world is turned upside down and villains

marvel s spider man 2 primer contacto y detalles del juego - Oct 04 2022

web sep 15 2023 historia de dos arañas tras haber protagonizado un juego cada uno peter parker y miles morales compartirán los focos en marvel s spider man 2 fuera de la

historias de spider man leo con marvel nivel 3 la download - Nov 05 2022

web historias de spider man leo con marvel nivel 3 la 1 historias de spider man leo con marvel nivel 3 la an english translation of claudius aelianus varia historia marvel

historias de spider man leo con marvel nivel 3 la - Nov 24 2021

web any way accompanied by them is this historias de spider man leo con marvel nivel 3 la that can be your partner amazing spider man dan slott 2015 04 29 step over the

marvel s spider man 2 nuevo tráiler del state of play detalles del - Dec 06 2022

web sep 14 2023 la edición digital deluxe en mayo también revelamos el lanzamiento de la edición digital deluxe de marvel

s spider man 2 que incluye 10 trajes de spider man

spider man life story vol 1 spider man wiki fandom - Jan 27 2022

web spider man life story vol 1 fue una serie de cómics de marvel comics que comenzó a publicarse en mayo de 2019 y culminó en octubre del mismo año la historia se centra

historias de spider man leo con marvel nivel 3 la - Feb 08 2023

web historias de spider man leo con marvel nivel 3 la is available in our book collection an online access to it is set as public so you can get it instantly our book servers saves in

historias de spider man leo con marvel nivel 3 la picadura de - Sep 03 2022

web jun 27 2023 historias de spider man leo con marvel nivel 3 la picadura de la viuda el increíble spider hulk choque de portales la venganza de misterio by marvel un

nuevas aventuras de spider man leo con marvel nivel 3 una - Mar 09 2023

web nuevas aventuras de spider man leo con marvel nivel 3 una noche muy extraña spider man a la caza de black panther veo manchas marvel amazon com tr kitap

historias de spider man leo con marvel nivel 3 la 2022 - Aug 02 2022

web historias de spider man leo con marvel nivel 3 la amazing spider man vol 1 museo spider man spider man la gran historia ultimate spider man spider man spider

historias de spider man leo con marvel nivel 3 la picadura de - Jul 21 2021

web jul 17 2023 historias de spider man leo con marvel nivel 3 la picadura de la viuda el increíble spider hulk choque de portales la venganza de misterio by marvel the

spider man sus historias más importantes y sus momentos clave - Oct 24 2021

web jun 14 2015 el asombroso spider man es uno de los héroes más conocidos de marvel comics tiene relatos importantísimas y también momentos clave en su carrera

historias de spider man leo con marvel nivel 3 la - Dec 26 2021

web historias de spider man leo con marvel nivel 3 la 1 historias de spider man leo con marvel nivel 3 la as recognized adventure as with ease as experience about lesson

historias de spider man leo con marvel nivel 3 la picadura - Jul 13 2023

web historias de spider man leo con marvel nivel 3 la picadura de la viuda el increíble spider hulk choque de portales la venganza de misterio marvel amazon es libros

los mejores libros de spider man para todas las edades sapos - Feb 25 2022

web 7 spider man toda una vida autores chip zdarsky y mark bagley edad 12 se publicó en 2020 para celebrar el octogésimo

aniversario de marvel y contiene spider man life

las mejores historias de spider man en los cómics - Sep 22 2021

web mar 23 2020 las mejores historias de spider man en los cómics desde su primera aparición en amazing fantasy 15 1961 sabemos que spider man ha sido uno de los

descarga historias de spider man leo con marvel nivel 3 la - Aug 22 2021

web feb 27 2020 historias de spider man leo con marvel nivel 3 la picadura de la viuda el increíble spider hulk choque de portales la venganza de misterio de

historias de spider man leo con marvel nivel 3 - Jun 12 2023

web el libro infantil historias de spider man leo con marvel nivel 3 la picadura de la viuda el increíble spider hulk choque de portales

historias de spider man leo con marvel nivel 3 la 2022 - Mar 29 2022

web spider man incluidas algunas piezas de los archivos de marvel comics que rara vez se han visto descubre cómo stan lee y steve ditko le dieron vida a este héroe arácnido y

historias de spider man leo con marvel nivel 3 la picadura - Aug 14 2023

web historias de spider man leo con marvel nivel 3 la picadura de la viuda el increíble spider hulk choque de portales la venganza de misterio marvel amazon com tr

historias de spider man leo con marvel nivel 3 la picadura de - May 31 2022

web jun 25 2023 historias de spider man leo con marvel nivel 3 la picadura de la viuda el increíble spider hulk choque de portales la venganza de misterio by marvel

historias de spider man leo con marvel nivel 3 librotea - May 11 2023

web aprende a leer con las aventuras del superhéroe preferido de niños y niñas y con la viuda negra iron man el capitán américa hulk thor emoción y adrenalina para lectores

primeras impresiones marvel s spider man 2 se agranda - Jan 07 2023

web 3 hours ago nuevo tráiler de la historia de marvel s spider man 2 presentado por playstation el juego se desarrolla nueve meses después de los eventos ocurridos en