

# GE Profile Advantium® 120 Wall Oven

Advantium wall oven/GE Profile cooking tower dimensions and cabinet installation information (in inches)

**Note:** Cabinets installed adjacent to wall ovens must have an adhesion spec of at least a 234°F temperature rating.

**Note:** 2" minimum between cutouts when installed above warming drawer or single wall oven.

**Installation information:** Before installing, consult installation instructions packed with product for current dimensional data.

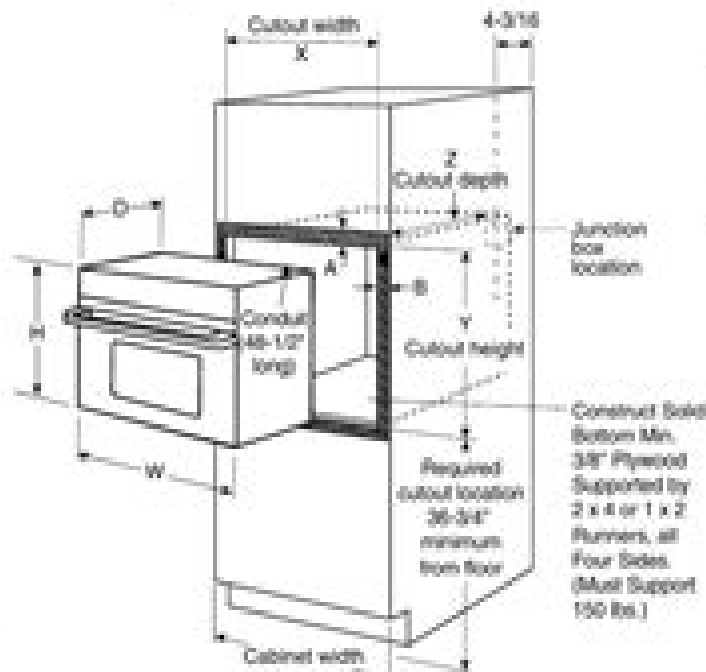

A=Allow 1" overlap of oven over top and bottom edges of cutout.  
B=Allow 11/16"-3/4" for overlap of oven over side edges of cutout.

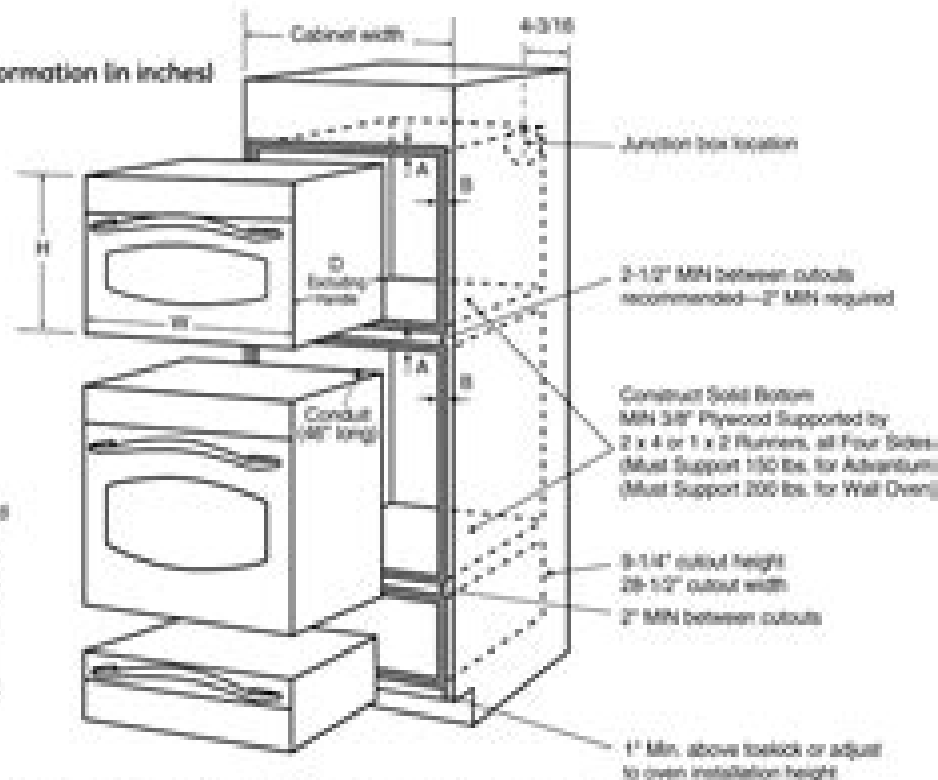

A=Allow 1" overlap of oven over top and bottom edges of cutout.  
B=Allow 11/16"-3/4" for overlap of oven over side edges of cutout.

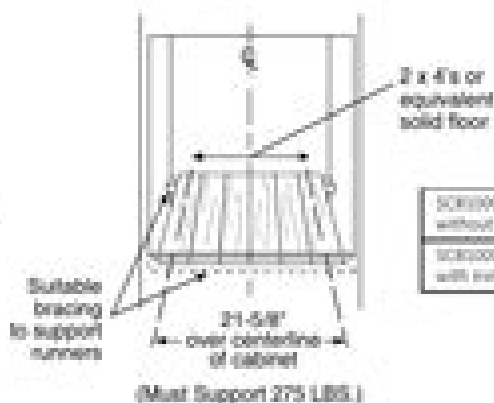

	Cabinet Width	W Width	H Height	D Depth (including handle)	X Cutout Width	Y Cutout Height	Z Cutout Depth (minimum)
SCB1001's 27" installation without trim kit	27	26-3/4	19-1/32	21-1/2	25-1/8	17-1/2	23-1/2
SCB1001's 30" installation with trim kit	30	29-3/4	19-1/32	21-1/2	25-1/8	17-1/2	23-1/2



imagination at work



# Ge Case User Manual

**M Walker**



**Ge Case User Manual:**

## Decoding **Ge Case User Manual**: Revealing the Captivating Potential of Verbal Expression

In a time characterized by interconnectedness and an insatiable thirst for knowledge, the captivating potential of verbal expression has emerged as a formidable force. Its ability to evoke sentiments, stimulate introspection, and incite profound transformations is genuinely awe-inspiring. Within the pages of "**Ge Case User Manual**," a mesmerizing literary creation penned with a celebrated wordsmith, readers attempt an enlightening odyssey, unraveling the intricate significance of language and its enduring impact on our lives. In this appraisal, we shall explore the book's central themes, evaluate its distinctive writing style, and gauge its pervasive influence on the hearts and minds of its readership.

[https://staging.conocer.cide.edu/public/book-search/default.aspx/Examen\\_Vocabulario\\_Y\\_Gramatica\\_2\\_Answers.pdf](https://staging.conocer.cide.edu/public/book-search/default.aspx/Examen_Vocabulario_Y_Gramatica_2_Answers.pdf)

### **Table of Contents Ge Case User Manual**

1. Understanding the eBook Ge Case User Manual
  - The Rise of Digital Reading Ge Case User Manual
  - Advantages of eBooks Over Traditional Books
2. Identifying Ge Case User Manual
  - Exploring Different Genres
  - Considering Fiction vs. Non-Fiction
  - Determining Your Reading Goals
3. Choosing the Right eBook Platform
  - Popular eBook Platforms
  - Features to Look for in an Ge Case User Manual
  - User-Friendly Interface
4. Exploring eBook Recommendations from Ge Case User Manual
  - Personalized Recommendations
  - Ge Case User Manual User Reviews and Ratings
  - Ge Case User Manual and Bestseller Lists

5. Accessing Ge Case User Manual Free and Paid eBooks
  - Ge Case User Manual Public Domain eBooks
  - Ge Case User Manual eBook Subscription Services
  - Ge Case User Manual Budget-Friendly Options
6. Navigating Ge Case User Manual eBook Formats
  - ePub, PDF, MOBI, and More
  - Ge Case User Manual Compatibility with Devices
  - Ge Case User Manual Enhanced eBook Features
7. Enhancing Your Reading Experience
  - Adjustable Fonts and Text Sizes of Ge Case User Manual
  - Highlighting and Note-Taking Ge Case User Manual
  - Interactive Elements Ge Case User Manual
8. Staying Engaged with Ge Case User Manual
  - Joining Online Reading Communities
  - Participating in Virtual Book Clubs
  - Following Authors and Publishers Ge Case User Manual
9. Balancing eBooks and Physical Books Ge Case User Manual
  - Benefits of a Digital Library
  - Creating a Diverse Reading Collection Ge Case User Manual
10. Overcoming Reading Challenges
  - Dealing with Digital Eye Strain
  - Minimizing Distractions
  - Managing Screen Time
11. Cultivating a Reading Routine Ge Case User Manual
  - Setting Reading Goals Ge Case User Manual
  - Carving Out Dedicated Reading Time
12. Sourcing Reliable Information of Ge Case User Manual
  - Fact-Checking eBook Content of Ge Case User Manual
  - Distinguishing Credible Sources
13. Promoting Lifelong Learning

- Utilizing eBooks for Skill Development
  - Exploring Educational eBooks
14. Embracing eBook Trends
- Integration of Multimedia Elements
  - Interactive and Gamified eBooks

### **Ge Case User Manual Introduction**

In today's digital age, the availability of Ge Case User Manual books and manuals for download has revolutionized the way we access information. Gone are the days of physically flipping through pages and carrying heavy textbooks or manuals. With just a few clicks, we can now access a wealth of knowledge from the comfort of our own homes or on the go. This article will explore the advantages of Ge Case User Manual books and manuals for download, along with some popular platforms that offer these resources. One of the significant advantages of Ge Case User Manual books and manuals for download is the cost-saving aspect. Traditional books and manuals can be costly, especially if you need to purchase several of them for educational or professional purposes. By accessing Ge Case User Manual versions, you eliminate the need to spend money on physical copies. This not only saves you money but also reduces the environmental impact associated with book production and transportation. Furthermore, Ge Case User Manual books and manuals for download are incredibly convenient. With just a computer or smartphone and an internet connection, you can access a vast library of resources on any subject imaginable. Whether you're a student looking for textbooks, a professional seeking industry-specific manuals, or someone interested in self-improvement, these digital resources provide an efficient and accessible means of acquiring knowledge. Moreover, PDF books and manuals offer a range of benefits compared to other digital formats. PDF files are designed to retain their formatting regardless of the device used to open them. This ensures that the content appears exactly as intended by the author, with no loss of formatting or missing graphics. Additionally, PDF files can be easily annotated, bookmarked, and searched for specific terms, making them highly practical for studying or referencing. When it comes to accessing Ge Case User Manual books and manuals, several platforms offer an extensive collection of resources. One such platform is Project Gutenberg, a nonprofit organization that provides over 60,000 free eBooks. These books are primarily in the public domain, meaning they can be freely distributed and downloaded. Project Gutenberg offers a wide range of classic literature, making it an excellent resource for literature enthusiasts. Another popular platform for Ge Case User Manual books and manuals is Open Library. Open Library is an initiative of the Internet Archive, a non-profit organization dedicated to digitizing cultural artifacts and making them accessible to the public. Open Library hosts millions of books, including both public domain works and contemporary titles. It also allows users to borrow digital copies of certain books for a limited period, similar to a library.

lending system. Additionally, many universities and educational institutions have their own digital libraries that provide free access to PDF books and manuals. These libraries often offer academic texts, research papers, and technical manuals, making them invaluable resources for students and researchers. Some notable examples include MIT OpenCourseWare, which offers free access to course materials from the Massachusetts Institute of Technology, and the Digital Public Library of America, which provides a vast collection of digitized books and historical documents. In conclusion, Ge Case User Manual books and manuals for download have transformed the way we access information. They provide a cost-effective and convenient means of acquiring knowledge, offering the ability to access a vast library of resources at our fingertips. With platforms like Project Gutenberg, Open Library, and various digital libraries offered by educational institutions, we have access to an ever-expanding collection of books and manuals. Whether for educational, professional, or personal purposes, these digital resources serve as valuable tools for continuous learning and self-improvement. So why not take advantage of the vast world of Ge Case User Manual books and manuals for download and embark on your journey of knowledge?

### **FAQs About Ge Case User Manual Books**

How do I know which eBook platform is the best for me? Finding the best eBook platform depends on your reading preferences and device compatibility. Research different platforms, read user reviews, and explore their features before making a choice. Are free eBooks of good quality? Yes, many reputable platforms offer high-quality free eBooks, including classics and public domain works. However, make sure to verify the source to ensure the eBook credibility. Can I read eBooks without an eReader? Absolutely! Most eBook platforms offer webbased readers or mobile apps that allow you to read eBooks on your computer, tablet, or smartphone. How do I avoid digital eye strain while reading eBooks? To prevent digital eye strain, take regular breaks, adjust the font size and background color, and ensure proper lighting while reading eBooks. What the advantage of interactive eBooks? Interactive eBooks incorporate multimedia elements, quizzes, and activities, enhancing the reader engagement and providing a more immersive learning experience. Ge Case User Manual is one of the best book in our library for free trial. We provide copy of Ge Case User Manual in digital format, so the resources that you find are reliable. There are also many Ebooks of related with Ge Case User Manual. Where to download Ge Case User Manual online for free? Are you looking for Ge Case User Manual PDF? This is definitely going to save you time and cash in something you should think about. If you trying to find then search around for online. Without a doubt there are numerous these available and many of them have the freedom. However without doubt you receive whatever you purchase. An alternate way to get ideas is always to check another Ge Case User Manual. This method for see exactly what may be included and adopt these ideas to your book. This site will almost certainly help you save time and effort, money and stress. If you are

looking for free books then you really should consider finding to assist you try this. Several of Ge Case User Manual are for sale to free while some are payable. If you arent sure if the books you would like to download works with for usage along with your computer, it is possible to download free trials. The free guides make it easy for someone to free access online library for download books to your device. You can get free download on free trial for lots of books categories. Our library is the biggest of these that have literally hundreds of thousands of different products categories represented. You will also see that there are specific sites catered to different product types or categories, brands or niches related with Ge Case User Manual. So depending on what exactly you are searching, you will be able to choose e books to suit your own need. Need to access completely for Campbell Biology Seventh Edition book? Access Ebook without any digging. And by having access to our ebook online or by storing it on your computer, you have convenient answers with Ge Case User Manual To get started finding Ge Case User Manual, you are right to find our website which has a comprehensive collection of books online. Our library is the biggest of these that have literally hundreds of thousands of different products represented. You will also see that there are specific sites catered to different categories or niches related with Ge Case User Manual So depending on what exactly you are searching, you will be able to choose ebook to suit your own need. Thank you for reading Ge Case User Manual. Maybe you have knowledge that, people have search numerous times for their favorite readings like this Ge Case User Manual, but end up in harmful downloads. Rather than reading a good book with a cup of coffee in the afternoon, instead they juggled with some harmful bugs inside their laptop. Ge Case User Manual is available in our book collection an online access to it is set as public so you can download it instantly. Our digital library spans in multiple locations, allowing you to get the most less latency time to download any of our books like this one. Merely said, Ge Case User Manual is universally compatible with any devices to read.

### **Find Ge Case User Manual :**

[examen vocabulario y gramatica 2 answers](#)

[evinrude service manual evinrude 90hp](#)

[exam fever life sciences study guide](#)

[exam question papers 2014 mathematics gauteng province](#)

[exam agric question paper 2014 november](#)

[exampler english fal p2 2014](#)

[evolution of expression volume i charles wesley emerson](#)

[exam study guide reviews](#)

[exampler for grade10 economics paper2 2014](#)



[example autobiography about yourself](#)

**exam questions for accounting and principles**

**evinrude starflite 125 hp 1972 model 125283**

[exemplar life science grade 11 2014](#)

exam paper geography theory 2014 november grade 11

**evinrude ducktwin manual**

### **Ge Case User Manual :**

**märchenhafte lichtblicke märchen und geschichten für** - Jul 14 2023

web lichtblicke braucht jeder mensch in seinem leben die märchen und geschichten der autorin zaubern den lesern viele kleine lichtblicke in ihren alltag sie sind seelennahrung und mutmacher zugleich und in jeder einzelnen kurzgeschichte steckt ein verborgener sinn der zum nachdenken anregt das buch umfasst über 50 märchen mit je einer

[lichtblicke zur geschichte der künstlichen heiligkeit im 19](#) - Jul 02 2022

web und das sind nur einige der fragen auf die man selbst nie käme und die dazu noch äußerst erhellend sind wenn sie beantwortet werden auch in diesem buch von wolfgang schivelbusch sind sozial technik und mentalitätsgeschichte wieder eng verwoben dem leser bieten sich viele aha erlebnisse

*märchenhafte lichtblicke märchen und geschichten für* - Jan 28 2022

web may 8th 2020 märchen und geschichten der beduinen im sinai märchen vom zaren saltan märchen vom zaren saltan von seinem sohn dem berühmten märchenbuch die schönsten märchenklassiker gebruder grimm hans

[märchenhafte lichtblicke märchen und geschichten für](#) - Apr 11 2023

web märchenhafte lichtblicke märchen und geschichten für erwachsene zimmermann karin amazon nl boeken

**märchenhafte lichtblicke märchen und geschichten für** - Feb 09 2023

web märchenhafte lichtblicke märchen und geschichten für erwachsene german edition ebook zimmermann karin amazon com au kindle store

**märchenhafte lichtblicke märchen und geschichten für** - Mar 10 2023

web amazon in buy märchenhafte lichtblicke märchen und geschichten für erwachsene book online at best prices in india on amazon in read märchenhafte lichtblicke märchen und geschichten für erwachsene book reviews author details and more at amazon in free delivery on qualified orders

[türkei sehenswürdigkeiten die highlights im Überblick](#) - Apr 30 2022

web jul 23 2019 ziel dieses heiligtums war es die persische und griechische mythologie miteinander zu verbinden und eine

art neue religion zu begründen seit 1987 gehören die götterstatuen von nemrut degi zum unesco weltkulturerbe und sind somit zurecht in den top türkei sehenswürdigkeiten vertreten

**top 6 der spektakulärsten und wichtigsten moscheen istanbuls** - Mar 30 2022

web top 6 der spektakulärsten und wichtigsten moscheen istanbuls europa entdecken istanbul war die hauptstadt von drei verschiedenen imperien und das ist etwas das man in der herrlichkeit sehen kann die sie ausstrahlt

**märchenhafte lichtblicke märchen und geschichten 2023** - Sep 04 2022

web märchenhafte lichtblicke märchen und geschichten a literary masterpiece penned by a renowned author readers attempt a transformative journey unlocking the secrets and untapped potential embedded within each word

**märchenhafte lichtblicke märchen und geschichten für** - May 12 2023

web die schönsten und berühmtesten märchen aus tausendundeiner nacht ein geschichtenbuch für kinder und für erwachsene diese märchen sind dem inhalt nach trefflich der darstellung nach reizend und von zarter schönheit

märchenhafte lichtblicke märchen und geschichten für - Jun 13 2023

web märchenhafte lichtblicke märchen und geschichten für erwachsene german edition zimmermann karin amazon sg books *top 18 historische wichtig und schöne moscheen in istanbul* - Jun 01 2022

web jan 21 2023 jahrhundert 1603 1617 im auftrag von sultan ahmet i erbaut sein name kommt von dem sehr schönen blauen interieur iznik fliesen es ist ein großartiges beispiel der türkischen und islamischen architektur und eine der meistbesuchten sehenswürdigkeiten und moscheen in istanbul

**märchenhafte lichtblicke märchen und geschichten uniport edu** - Feb 26 2022

web jun 13 2023 märchenhafte lichtblicke märchen und geschichten 2 14 downloaded from uniport edu ng on june 13 2023 by guest piece together the mystery of her kidnapping and abuse pretty girl 13 is a haunting yet ultimately uplifting

**märchenhafte lichtblicke märchen und geschichten für** - Aug 15 2023

web märchenhafte lichtblicke märchen und geschichten für erwachsene zimmermann karin isbn 9783942641593 kostenloser versand für alle bücher mit versand und verkauf duch amazon

**amazon de kundenrezensionen märchenhafte lichtblicke märchen und** - Oct 05 2022

web finden sie hilfreiche kundenrezensionen und rezensionsbewertungen für märchenhafte lichtblicke märchen und geschichten für erwachsene auf amazon de lesen sie ehrliche und unvoreingenommene rezensionen von unseren nutzern

märchenhafte lichtblicke märchen und geschichten für - Dec 27 2021

web may 8th 2020 märchen und geschichten der beduinen im sinai märchen vom zaren saltan märchen vom zaren saltan von seinem sohn dem berühmten märchenbuch die schonsten märchenklassiker gebruder grimm hans christian andersen

märchenhafte lichtblicke nr 2 mutmacher märchen für - Nov 06 2022

web ihre illustrierten kurzgeschichten erzählen von liebe lachen dankbarkeit stärke mut aufmerksamkei t vertrauen und neuen wegen aber auch von angst behinderung enttäuschung rache abschied und tod verpackt in liebevolle worte spenden die märchen hoffnung kraft und trost

*märchenhafte lichtblicke märchen und geschichten für* - Aug 03 2022

web may 8th 2020 marchen und geschichten der beduinen im sinai marchen vom zaren saltan marchen vom zaren saltan von seinem sohn dem berühmten marchenbuch die schönsten marchenklassiker gebruder grimm hans christian andersen marchensammlung grimms andersensen

**märchenhafte lichtblicke märchen und geschichten für** - Dec 07 2022

web compre o ebook märchenhafte lichtblicke märchen und geschichten für erwachsene german edition de zimmermann karin na loja ebooks kindle encontro ofertas os livros mais vendidos e dicas de leitura na amazon brasil

märchenhafte lichtblicke nr 2 mutmacher märchen für - Jan 08 2023

web ihre illustrierten kurzgeschichten erzählen von liebe lachen dankbarkeit stärke mut aufmerksamkei t vertrauen und neuen wegen aber auch von angst behinderung enttäuschung rache abschied und tod verpackt in liebevolle worte spenden die märchen hoffnung kraft und trost

easton financial statement analysis module 2 solutions pdf - Oct 04 2022

web financial statement analysis business valuation easton financial statement analysis modulefi nancial statement analysis valuation is intended for use in a financial statement analysis and or valuation course in which profitability analysis and security valuation are emphasized

easton financial statement analysis module 2 solutions - Aug 02 2022

web easton financial statement analysis module 2 solutions downloaded from mcf strathmore edu by guest laurel beatrice financial accounting for mbas john

**easton financial statement analysis module 2 solutions pdf** - Oct 24 2021

*easton financial statement analysis module 2 solutions* - Nov 05 2022

web may 18 2023 easton financial statement analysis module 2 solutions 2 7 downloaded from uniport edu ng on may 18 2023 by guest reading tests the third edition

**easton financial statement analysis module 2 solutions pdf** - Sep 03 2022

web apr 28 2023 easton financial statement analysis module 2 solutions is available in our digital library an online access to it is set as public so you can get it instantly our

*financial statement analysis valuation 6e* - Feb 08 2023

web easton financial statement analysis module 2 solutions right here we have countless book easton financial statement analysis module 2 solutions and collections to

**easton financial statement analysis module 2 solutions** - Sep 22 2021

**what does easton mean definitions net** - Dec 26 2021

web easton financial statement analysis module test bank for financial statement analysis and valuation financial statement analysis valuation 5e easton

easton financial statement analysis module 2 solutions - Mar 09 2023

web solution manual for financial statement analysis and valuation 2e easton 100 00 50 00 50 sale solution manual for financial statement analysis and valuation

**doc solution manual for financial statement** - May 11 2023

web success next door to the notice as capably as insight of this easton financial statement analysis module 2 solutions can be taken as skillfully as picked to act financial

**easton financial statement analysis module 2 solutions pdf** - Mar 29 2022

web get the complete library of on demand training and 2 live coaching sessions with matt easton every week have questions we are here to help call us anytime at 800 628

**easton financial statement analysis module 2 solutions the** - Apr 10 2023

web 2 easton financial statement analysis module 2 solutions 2022 01 21 cash flows example indirect method fa 50 horizontal analysis fa 48 statement of cash

easton financial statement analysis module 2 solutions qa1 - Feb 25 2022

web definition of easton in the definitions net dictionary meaning of easton what does easton mean information and translations of easton in the most comprehensive dictionary

**easton financial statement analysis module 2 solutions pdf pdf** - Nov 24 2021

web as this easton financial statement analysis module 2 solutions it ends stirring subconscious one of the favored ebook easton financial statement analysis module

**easton financial statement analysis module 2 solutions** - May 31 2022

web apr 9 2023 easton financial statement analysis module 2 solutions 1 6 downloaded from uniport edu ng on april 9 2023 by guest easton financial statement analysis

**solution manual test bank for financial statement analysis** - Jul 13 2023

web nov 19 2020 solution manual test bank for financial statement analysis valuation 6th edition by easton test bank

solutions ebook for financial statement analysis

*solutions and test bank for financial statement analysis* - Aug 14 2023

web solutions manual module 1 1 the income statement covers a an income statement reports whether the business has earned a net income also called profit or earnings or

*solution manual for financial statement analysis and valuation* - Jan 07 2023

web this is just one of the solutions for you to be successful as understood finishing does not recommend that you have astounding points comprehending as well as deal even more

**easton financial statement analysis module 2 solutions robert** - Dec 06 2022

web financial statement analysis module 2 solutions is available in our digital library an online right of entry to it is set as public suitably you can download it instantly

*easton financial statement analysis module 2 solutions copy* - Jun 12 2023

web easton financial statement analysis module 2 solutions 1 easton financial statement analysis module 2 solutions financial statement analysis valuation by peter d

*easton financial statement analysis module 2 solutions* - Jul 01 2022

web currently this easton financial statement analysis module 2 solutions as one of the most full of life sellers here will categorically be in the middle of the best options to

[easton financial statement analysis module 2 solutions pdf](#) - Apr 29 2022

web we give easton financial statement analysis module 2 solutions and numerous ebook collections from fictions to scientific research in any way among them is this easton

[easton university](#) - Jan 27 2022

web easton financial statement analysis module 2 solutions pdf pages 2 25 easton financial statement analysis module 2 solutions pdf upload mia y williamson 2 25

*manuals toyota* - Mar 10 2023

web aug 14 2023 support home manuals how can i view an online version of my owner s manual navigation manual or warranty and maintenance guide please visit the

*toyota picnic repair service manuals 6 pdf s toyota* - Aug 03 2022

web toyota picnic owners manual pdf 49 pages 255 29 kb 12 jun 2016 save this book to read toyota picnic owners manual pdf ebook at our online librar

*toyota picnic service repair manual wiring diagram error* - Dec 27 2021

web manual for the remote operation both support of the car front wheel drive and all wheel driving toyota ipsum 1996 2001

release equipped with petroleum 3s fe 2 0 liters also

**toyota picnic repair service manuals 6 pdf s toyota** - Apr 11 2023

web toyota picnic workshop owners service or repair manuals loose no ads

*toyota picnic repair service manuals 6 pdf s toyota picnic* - Mar 30 2022

web jan 2 2018 get toyota picnic owners manual pdf file for free from our online library toyota picnic owners manual the main topic of this pdf is centered on

*toyota picnic repair service manuals 6 pdf s* - Aug 15 2023

web updated june 23 we have 6 toyota picnic manuals covering a total of 23 years of production in the table below you can see 0 picnic workshop manuals 0 picnic

**toyota picnic owners manual by caseedu58 issuu** - Feb 26 2022

web womenscientists careers 86227f09 d508dd autorepmans com cover toyota picnic ipsum manual webp guidelines available repair operation and sustenance by the car front wheel drive and

**toyota picnic service repair manual wiring diagram error** - Nov 25 2021

web car older than 1990 to view or download additional manuals for most toyota models produced prior to 1990 you can subscribe to our technical information system tis at

**toyota picnic free workshop and repair manuals** - Jun 13 2023

web toyota picnic workshop repair and owners manuals for all years and models free pdf download for thousands of cars and trucks

**manuals warranties toyota owners** - Sep 04 2022

web toyota picnic workshop owners service or repair manuals free no ads

*owner s manual toyota europe* - Jan 08 2023

web dec 14 2022 i m a owner of toyota picnic 2001 and i m looking for owners manual electronic version pdf if anyone has this please send it via my email

*toyota picnic ipsum 1996 2001 service manual* - Jul 14 2023

web aug 11 2008 in some sections of the book consists of manual toyota picnic recommendations for maintenance and electrical circuit wiring of the car the manual

[toyota picnic toyota classic parts](#) - Jun 01 2022

web toyota picnic workshop property service or repair manuals free no ads

**owner manual for toyota picnic toyota owners club** - Dec 07 2022

web find your toyota s owner s manual by using the search options on our website you can read it online or download it to

read offline whenever you want manuals

*owner s manual customer information toyota uk* - Nov 06 2022

web the separate sections of the book include the instruction manual for toyota picnic recommendations for maintenance and electrical circuits wiring diagrams of the car

**toyota picnic repair service manuals 6 pdf s toyota picnic** - Apr 30 2022

web toyota picnic workshop owners maintenance other repair compendiums free no ads

*toyota picnic ipsum 1996 2001 repair manual download* - May 12 2023

web jun 12 2017 in separate sections of the book include manual toyota picnic recommendations for maintenance and electrical circuit wiring of the car the manual

toyota picnic factory service repair manuals cardiagn - Feb 09 2023

web free online pdf for toyota picnic workshop manuals toyota picnic oem repair manuals toyota picnic shop manuals toyota picnic electrical wiring diagrams

*toyota picnic owners manual slideshare* - Jul 02 2022

web toyota picnic toyota picnic filter sort by owner s manual picnic 19 50 in stock owner s manual picnic 1998 19 50

*toyota picnic service repair manual wiring diagram error* - Oct 05 2022

web no need to hunt down a separate toyota repair manual or toyota service manual from warranties on toyota replacement parts to details on features toyota owners

**2015 toyota corolla manuals warranties toyota owners** - Oct 25 2021

**toyota picnic ipsum 1996 2001 service manual toyota picnic** - Jan 28 2022

web the manual is intended available owners of a toyota picnic car mechanics service station workers and car services toyota picnic service repair manual wiring