

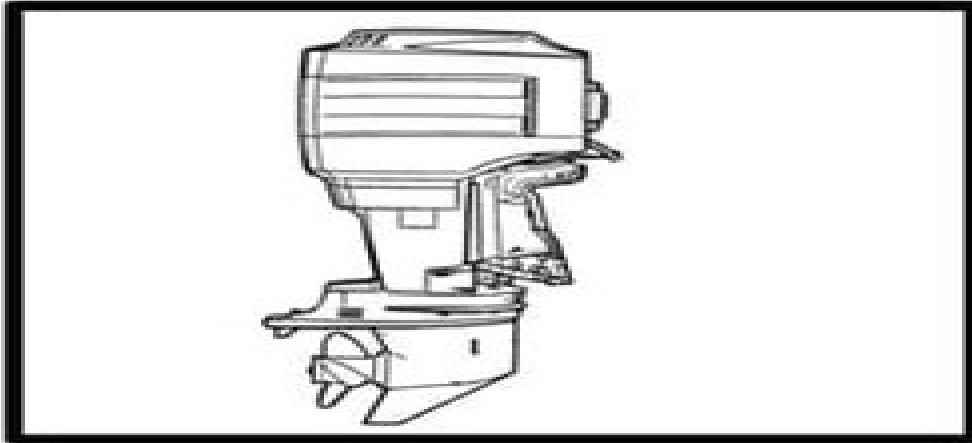

GENERAL INFORMATION AND SPECIFICATIONS

1



Mariner 90 Hp Outboard Manual

LL Leslie



Mariner 90 Hp Outboard Manual:

Mercury/Mariner Outboard Shop Manual Penton Staff,2016-07-15 Mercury Mariner 4 HP 1995 2006 Mercury Mariner 5 HP 1995 2006 Mercury Mariner 6 HP 1995 2006 Mercury Mariner 9 9 HP 1995 2006 Mercury Mariner 15 HP 1995 2006 Mercury Mariner 25 HP 1995 2006 Mercury Mariner 30 HP 1995 2006 Mercury Mariner 40 HP 1995 2006 Mercury Mariner 50 HP 1995 2006 Mercury Mariner 75 HP 1995 2006 Mercury Mariner 90 HP 1995 2006 Does not cover 60 HP models TROUBLESHOOTING LUBRICATION MAINTENANCE AND TUNE UP ENGINE TOP END ENGINE LOWER END CLUTCH AND EXTERNAL SHIFT MECHANISM TRANSMISSION AND INTERNAL SHIFT MECHANISM FUEL EMISSION CONTROL AND EXHAUST SYSTEMS ELECTRICAL SYSTEM COOLING SYSTEM WHEELS TIRES AND DRIVE CHAIN FRONT SUSPENSION AND STEERING REAR SUSPENSION BRAKES BODY AND FRAME COLOR WIRING DIAGRAMS Outboard Motor Service Manual Intertec Publishing,1987 Detailed tips on periodic servicing troubleshooting general maintenance and repair are explicitly outlined in this manual Repair is easy with the specifications and step by step repair procedures included for hundreds of models Volume II covers models with 30hp and above **Mercury/Mariner 4-Stroke OB 95-00** Penton Staff,2000-05-24 4 HP 5 HP 9 9 HP 15 HP 25 HP 30 HP 40 HP 50 HP 75 HP 90 HP *Mercury/Mariner Outboards 1990-00 Repair Manual* Seloc,2000 General information timing maintenance ignition trim and tilt remote control fuel injection and other topics about outboards Boating ,1979-07 **Mercury/Mariner 75-250 HP Two-Stroke 1998-2009** Editors of Clymer Manuals,2015-12-01 Mercury Mariner 65 Jet 1998 2009 Mercury Mariner 75 HP 1998 2009 Mercury Mariner 80 Jet 1998 2009 Mercury Mariner 90 Jet 1998 2009 Mercury Mariner 100 HP 1998 2009 Mercury Mariner 105 Jet 1998 2009 Mercury Mariner 115 HP 4 Cyl 1998 2009 Mercury Mariner 115 HP Optimax V 6 1998 2009 Mercury Mariner 125 HP 1998 2009 Mercury Mariner 135 HP 1998 2009 Mercury Mariner 135 HP Optimax 1998 2009 Mercury Mariner 140 Jet 1998 2009 Mercury Mariner 150 HP Carburetor Equipped 1998 2009 Mercury Mariner 150 HP EFI 1998 2009 Mercury Mariner 150 XR6 1998 2009 Mercury Mariner 150 HP Optimax 1998 2009 Mercury Mariner 150 Mag III 1998 2009 Mercury Mariner 175 HP Carburetor Equipped 1998 2009 Mercury Mariner 175 HP EFI 1998 2009 Mercury Mariner 175 HP Optimax 1998 2009 Mercury Mariner 200 HP Carburetor Equipped 1998 2009 Mercury Mariner 200 HP EFI 1998 2009 Mercury Mariner 200 HP Optimax 1998 2009 Mercury Mariner 225 HP Carburetor Equipped 1998 2009 Mercury Mariner 225 HP EFI 1998 2009 Mercury Mariner 225 HP Optimax 1998 2009 Mercury Mariner 250 HP EFI 1998 2009 TROUBLESHOOTING LUBRICATION MAINTENANCE AND TUNE UP ENGINE TOP END ENGINE LOWER END CLUTCH AND EXTERNAL SHIFT MECHANISM TRANSMISSION AND INTERNAL SHIFT MECHANISM FUEL EMISSION CONTROL AND EXHAUST SYSTEMS ELECTRICAL SYSTEM COOLING SYSTEM WHEELS TIRES AND DRIVE CHAIN FRONT SUSPENSION AND STEERING REAR SUSPENSION BRAKES BODY AND FRAME COLOR WIRING DIAGRAMS **The Motor Boat & Marine Motor Manual** ,1934 MotorBoating ,1979-12 **Books in Print Supplement** ,2002 **Bibliography of Nautical Books** Alan

Obin,2000-02 This is the 15th annual edition of the Bibliography of Nautical Books a reference guide to over 14 000 nautical publications It deals specifically with the year 2000 Sea for the Active Boatman ,1980-07 The Cumulative Book Index ,1999 **Field & Stream** ,1977-12 FIELD STREAM America s largest outdoor sports magazine celebrates the outdoor experience with great stories compelling photography and sound advice while honoring the traditions hunters and fishermen have passed down for generations **The Motor Boat and Yachting Manual** ,1948 *Subject Guide to Books in Print* ,1993 **Field & Stream** ,1984-02 FIELD STREAM America s largest outdoor sports magazine celebrates the outdoor experience with great stories compelling photography and sound advice while honoring the traditions hunters and fishermen have passed down for generations Federal Trade Commission Decisions United States. Federal Trade Commission,1980 Field & Stream ,1998-05 FIELD STREAM America s largest outdoor sports magazine celebrates the outdoor experience with great stories compelling photography and sound advice while honoring the traditions hunters and fishermen have passed down for generations *Field & Stream* ,1976-12 FIELD STREAM America s largest outdoor sports magazine celebrates the outdoor experience with great stories compelling photography and sound advice while honoring the traditions hunters and fishermen have passed down for generations *Boating* ,1996-01

Embark on a transformative journey with is captivating work, Discover the Magic in **Mariner 90 Hp Outboard Manual** . This enlightening ebook, available for download in a convenient PDF format PDF Size: , invites you to explore a world of boundless knowledge. Unleash your intellectual curiosity and discover the power of words as you dive into this riveting creation. Download now and elevate your reading experience to new heights .

https://staging.conocer.cide.edu/files/publication/default.aspx/how_to_restore_ipod_classic_160gb_without_itunes.pdf

Table of Contents Mariner 90 Hp Outboard Manual

1. Understanding the eBook Mariner 90 Hp Outboard Manual
 - The Rise of Digital Reading Mariner 90 Hp Outboard Manual
 - Advantages of eBooks Over Traditional Books
2. Identifying Mariner 90 Hp Outboard Manual
 - Exploring Different Genres
 - Considering Fiction vs. Non-Fiction
 - Determining Your Reading Goals
3. Choosing the Right eBook Platform
 - Popular eBook Platforms
 - Features to Look for in an Mariner 90 Hp Outboard Manual
 - User-Friendly Interface
4. Exploring eBook Recommendations from Mariner 90 Hp Outboard Manual
 - Personalized Recommendations
 - Mariner 90 Hp Outboard Manual User Reviews and Ratings
 - Mariner 90 Hp Outboard Manual and Bestseller Lists
5. Accessing Mariner 90 Hp Outboard Manual Free and Paid eBooks
 - Mariner 90 Hp Outboard Manual Public Domain eBooks
 - Mariner 90 Hp Outboard Manual eBook Subscription Services
 - Mariner 90 Hp Outboard Manual Budget-Friendly Options

6. Navigating Mariner 90 Hp Outboard Manual eBook Formats
 - ePub, PDF, MOBI, and More
 - Mariner 90 Hp Outboard Manual Compatibility with Devices
 - Mariner 90 Hp Outboard Manual Enhanced eBook Features
7. Enhancing Your Reading Experience
 - Adjustable Fonts and Text Sizes of Mariner 90 Hp Outboard Manual
 - Highlighting and Note-Taking Mariner 90 Hp Outboard Manual
 - Interactive Elements Mariner 90 Hp Outboard Manual
8. Staying Engaged with Mariner 90 Hp Outboard Manual
 - Joining Online Reading Communities
 - Participating in Virtual Book Clubs
 - Following Authors and Publishers Mariner 90 Hp Outboard Manual
9. Balancing eBooks and Physical Books Mariner 90 Hp Outboard Manual
 - Benefits of a Digital Library
 - Creating a Diverse Reading Collection Mariner 90 Hp Outboard Manual
10. Overcoming Reading Challenges
 - Dealing with Digital Eye Strain
 - Minimizing Distractions
 - Managing Screen Time
11. Cultivating a Reading Routine Mariner 90 Hp Outboard Manual
 - Setting Reading Goals Mariner 90 Hp Outboard Manual
 - Carving Out Dedicated Reading Time
12. Sourcing Reliable Information of Mariner 90 Hp Outboard Manual
 - Fact-Checking eBook Content of Mariner 90 Hp Outboard Manual
 - Distinguishing Credible Sources
13. Promoting Lifelong Learning
 - Utilizing eBooks for Skill Development
 - Exploring Educational eBooks
14. Embracing eBook Trends
 - Integration of Multimedia Elements

- Interactive and Gamified eBooks

Mariner 90 Hp Outboard Manual Introduction

In today's digital age, the availability of Mariner 90 Hp Outboard Manual books and manuals for download has revolutionized the way we access information. Gone are the days of physically flipping through pages and carrying heavy textbooks or manuals. With just a few clicks, we can now access a wealth of knowledge from the comfort of our own homes or on the go. This article will explore the advantages of Mariner 90 Hp Outboard Manual books and manuals for download, along with some popular platforms that offer these resources. One of the significant advantages of Mariner 90 Hp Outboard Manual books and manuals for download is the cost-saving aspect. Traditional books and manuals can be costly, especially if you need to purchase several of them for educational or professional purposes. By accessing Mariner 90 Hp Outboard Manual versions, you eliminate the need to spend money on physical copies. This not only saves you money but also reduces the environmental impact associated with book production and transportation. Furthermore, Mariner 90 Hp Outboard Manual books and manuals for download are incredibly convenient. With just a computer or smartphone and an internet connection, you can access a vast library of resources on any subject imaginable. Whether you're a student looking for textbooks, a professional seeking industry-specific manuals, or someone interested in self-improvement, these digital resources provide an efficient and accessible means of acquiring knowledge. Moreover, PDF books and manuals offer a range of benefits compared to other digital formats. PDF files are designed to retain their formatting regardless of the device used to open them. This ensures that the content appears exactly as intended by the author, with no loss of formatting or missing graphics. Additionally, PDF files can be easily annotated, bookmarked, and searched for specific terms, making them highly practical for studying or referencing. When it comes to accessing Mariner 90 Hp Outboard Manual books and manuals, several platforms offer an extensive collection of resources. One such platform is Project Gutenberg, a nonprofit organization that provides over 60,000 free eBooks. These books are primarily in the public domain, meaning they can be freely distributed and downloaded. Project Gutenberg offers a wide range of classic literature, making it an excellent resource for literature enthusiasts. Another popular platform for Mariner 90 Hp Outboard Manual books and manuals is Open Library. Open Library is an initiative of the Internet Archive, a non-profit organization dedicated to digitizing cultural artifacts and making them accessible to the public. Open Library hosts millions of books, including both public domain works and contemporary titles. It also allows users to borrow digital copies of certain books for a limited period, similar to a library lending system. Additionally, many universities and educational institutions have their own digital libraries that provide free access to PDF books and manuals. These libraries often offer academic texts, research papers, and technical manuals, making them invaluable resources for students and researchers. Some notable examples include MIT OpenCourseWare, which offers free

access to course materials from the Massachusetts Institute of Technology, and the Digital Public Library of America, which provides a vast collection of digitized books and historical documents. In conclusion, Mariner 90 Hp Outboard Manual books and manuals for download have transformed the way we access information. They provide a cost-effective and convenient means of acquiring knowledge, offering the ability to access a vast library of resources at our fingertips. With platforms like Project Gutenberg, Open Library, and various digital libraries offered by educational institutions, we have access to an ever-expanding collection of books and manuals. Whether for educational, professional, or personal purposes, these digital resources serve as valuable tools for continuous learning and self-improvement. So why not take advantage of the vast world of Mariner 90 Hp Outboard Manual books and manuals for download and embark on your journey of knowledge?

FAQs About Mariner 90 Hp Outboard Manual Books

1. Where can I buy Mariner 90 Hp Outboard Manual books? Bookstores: Physical bookstores like Barnes & Noble, Waterstones, and independent local stores. Online Retailers: Amazon, Book Depository, and various online bookstores offer a wide range of books in physical and digital formats.
2. What are the different book formats available? Hardcover: Sturdy and durable, usually more expensive. Paperback: Cheaper, lighter, and more portable than hardcovers. E-books: Digital books available for e-readers like Kindle or software like Apple Books, Kindle, and Google Play Books.
3. How do I choose a Mariner 90 Hp Outboard Manual book to read? Genres: Consider the genre you enjoy (fiction, non-fiction, mystery, sci-fi, etc.). Recommendations: Ask friends, join book clubs, or explore online reviews and recommendations. Author: If you like a particular author, you might enjoy more of their work.
4. How do I take care of Mariner 90 Hp Outboard Manual books? Storage: Keep them away from direct sunlight and in a dry environment. Handling: Avoid folding pages, use bookmarks, and handle them with clean hands. Cleaning: Gently dust the covers and pages occasionally.
5. Can I borrow books without buying them? Public Libraries: Local libraries offer a wide range of books for borrowing. Book Swaps: Community book exchanges or online platforms where people exchange books.
6. How can I track my reading progress or manage my book collection? Book Tracking Apps: Goodreads, LibraryThing, and Book Catalogue are popular apps for tracking your reading progress and managing book collections. Spreadsheets: You can create your own spreadsheet to track books read, ratings, and other details.
7. What are Mariner 90 Hp Outboard Manual audiobooks, and where can I find them? Audiobooks: Audio recordings of

- books, perfect for listening while commuting or multitasking. Platforms: Audible, LibriVox, and Google Play Books offer a wide selection of audiobooks.
8. How do I support authors or the book industry? Buy Books: Purchase books from authors or independent bookstores. Reviews: Leave reviews on platforms like Goodreads or Amazon. Promotion: Share your favorite books on social media or recommend them to friends.
 9. Are there book clubs or reading communities I can join? Local Clubs: Check for local book clubs in libraries or community centers. Online Communities: Platforms like Goodreads have virtual book clubs and discussion groups.
 10. Can I read Mariner 90 Hp Outboard Manual books for free? Public Domain Books: Many classic books are available for free as they're in the public domain. Free E-books: Some websites offer free e-books legally, like Project Gutenberg or Open Library.

Find Mariner 90 Hp Outboard Manual :

[how to restore ipod classic 160gb without itunes](#)

[how to sync iphone calendar with mobile me](#)

how to use microsoft windows xp walter j glenn

[hp 12x1531 laptops owners manual](#)

how to write a paper on visual description art

how to teach grammar 1

[how to wire vtec obd1](#)

hp 1055cm service manual

how to use manual focus on nikon d3200

[how to test an ac capacitor with a multimeter](#)

how to start a 4 wheeler without the key

hp 21s user manual

how to turn off alarm on casio pathfinder

how to write informal report

hp 20disassembly guide

Mariner 90 Hp Outboard Manual :

poe s short stories the tell tale heart sparknotes - Jan 13 2023

web poe s short stories the pit and the pendulum sparknotes looking for exclusive start your 7 day free trial now poe s short stories edgar allan poe study guide full

poe s short stories edgar allan poe and poe s short stories - Jul 07 2022

web course of guides you could enjoy now is poe s short stories sparknotes literature study g below the house of the spirits isabel allende 2015 12 15 the trueba family

poe s short stories sparknotes - Nov 30 2021

web in this detective story poe introduces the brilliant sleuth c auguste dupin when the paris police arbitrarily arrest dupin s friend for the gruesome murders of a mother and

poe s short stories character list sparknotes - May 17 2023

web analysis poe uses his words economically in the tell tale heart it is one of his shortest stories to provide a study of paranoia and mental deterioration poe strips the story of

poe s stories study guide literature guide litcharts - Jul 19 2023

web aug 12 2014 poe s short stories sparknotes literature guide by edgar allan poe making the reading experience fun created by harvard students for students

poe s short stories sparknotes literature study g ernest - Apr 04 2022

web aug 26 2023 poe s otherworldly narrative could easily fall in the same category as the sea voyages and tribulations described by later authors such as herman melville and joseph

poe s short stories the black cat 1843 summary analysis - Mar 15 2023

web who would dare the thief said g is the minister d who dares all things those unbecoming as well as those becoming a man the method of the theft was not less

poe s short stories the purloined letter sparknotes - Feb 14 2023

web poe s short stories edgar allan poe study guide full text mastery quizzes plus flashcards plus full text the tell tale heart true nervous very very

poe s short stories sparknotes literature guides by edgar - Oct 10 2022

web nov 12 2022 take a quiz about the important details and events in overview of poe s short stories

poe s short stories suggestions for further reading sparknotes - Jan 01 2022

web poe s short stories the purloined letter 1844 quiz quick quiz sparknotes study guide full text mastery quizzes flashcards quick quizzes the purloined letter

poe s short stories study guide sparknotes - Sep 21 2023

web eleven of poe s short stories are discussed here they are ms found in a bottle ligeia the fall of the house of usher william wilson the murders in the rue

poe s short stories sparklet story summaries sparknotes - Feb 02 2022

web a suggested list of literary criticism on edgar allan poe s poe s short stories the listed critical essays and books will be invaluable for writing essays and papers on poe s short

poe s short stories summary and analysis of the purloined letter - Nov 11 2022

web read 270 reviews from the world s largest community for readers spark publishing s literature guides are celebrating their 5th anniversary to celebrate

poe s short stories sparknotes - Apr 16 2023

web a summary of the black cat 1843 in edgar allan poe s poe s short stories learn exactly what happened in this chapter scene or section of poe s short stories and

poe s short stories sparknotes literature guide scribd - Jun 18 2023

web poe s short stories character list sparknotes sparkplus20 see poe s short stories edgar allan poe study guide full book summary key facts characters

poe s short stories sparknotes literature study g - Jun 06 2022

web further research edward allan poe and poe s short stories background edgar joe poe was native for january 19 1809 the died on october 7 1849 includes his storming forty

poe s short stories full collection summary sparknotes - Oct 30 2021

poe s short stories overview quiz quick quiz sparknotes - Sep 09 2022

web poe s otherworldly narrative could easily fall in the same category as the sea voyages and tribulations described by later authors such as herman melville and joseph conrad

poe s short stories sparknotes literature study g pdf uniport edu - Mar 03 2022

web poe s short stories study guide full text mastery quizzes flashcards literary devices quotes summary sparklet story summaries ms found in a bottle 1833

poe s short stories sparknotes literature study g db csda - Aug 08 2022

web poe america s foremost south writer before william faulkner generated a gothic ethos from his own experiences in virginia and other slaveholding territories and the black real

poe s short stories the pit and the pendulum sparknotes - Dec 12 2022

web poe s short stories study guide contains a biography of edgar poe literature essays quiz questions major themes characters and a full summary and analysis best

poe s short stories edgar allan poe and poe s short stories - May 05 2022

web poe 2020 08 01 the black cat is a short story by edgar allan poe it was first published in the august 19 1843 edition of the saturday evening post it is a study of the

poe s short stories sparknotes - Aug 20 2023

web a summary of the purloined letter 1844 in edgar allan poe s poe s short stories learn exactly what happened in this chapter scene or section of poe s short stories

the sandman comic book wikipedia - Dec 27 2021

web jon j muth sherilyn van valkenburgh the sandman is a comic book written by neil gaiman and published by dc comics its artists include sam kieth mike dringenberg jill thompson shawn mcmanus marc hempel bryan talbot and michael zulli with lettering by todd klein and covers by dave mckean

the sandman konusu nedir the sandman dizisi oyunculari ve - Nov 06 2022

web aug 5 2022 the sandman dizisi konusu ve oyunculari ile dikkatleri üzerine çekiyor netflix in en pahalı yapımları arasında yer aldığı ifade edilen the sandman ın başrolünde tom sturridge yer

the sandman tv series 2022 imdb - Aug 15 2023

web the sandman created by neil gaiman david s goyer allan heinberg with tom sturridge boyd holbrook patton oswalt vivienne acheampong upon escaping after decades of imprisonment by a mortal wizard dream the personification of dreams sets about to reclaim his lost equipment

the sandman tv series wikipedia - Jun 13 2023

web the sandman is an american fantasy drama television series based on the 1989 1996 comic book written by neil gaiman and published by dc comics the series was developed by gaiman david s goyer and allan heinberg for the streaming service netflix and is produced by dc entertainment and warner bros television

the sandman 2 sezon ne zaman çıkacak sandman yeni sezon - Dec 07 2022

web aug 6 2022 beklenen dizi sandman nihayet 5 ağustıs 2022 tarihinde 1 sezonu ile yayına girdi kısa süre içinde milyonlarca hesap üzerinden izlenen dizi ülkemizde de popüler yapımlar arasında yer

the sandman tv series 2022 full cast crew imdb - Jan 28 2022

web the sandman tv series 2022 cast and crew credits including actors actresses directors writers and more menu movies release calendar top 250 movies most popular movies browse movies by genre top box office showtimes tickets movie news india movie spotlight tv shows

the sandman in en son oyuncu kadrosu ve ardındaki hikâyeler - Jan 08 2023

web may 26 2021 neil gaiman netflix için diziye uyarlanan the sandman de death desire despair johanna constantine ve çizgi romanın diğer sevilen karakterlerini canlandıracak oyuncuların ardındaki hikâyeleri açıklıyor

[the sandman dizi 2022 beyazperde com](#) - Mar 10 2023

web Özet ve detaylar neil gaiman ın dc comics vertigo etiketiyle basılan sandman çizgi romanları ekran izleyicisiyle buluşmaya hazırlanıyor netflix tarafından hayata geçirilen sandman uyarlaması live action formatlı bir dizi olarak izleyici karşısına çıkacak

[the sandman oyuncuları ve kadrosu sinemalar com](#) - Aug 03 2022

web the sandman filminin oyuncuları yönetmeni senaristi ve filmde görev yapan tüm isimler bu sayfada Üye girişi bildirimlerim yeni bildirim yok platformlar vizyondaki filmler yakında salonlar tüm filmler tüm diziler tüm sanatçılar

netflix dizisi sandman de bizi neler bekliyor webtekno - Oct 05 2022

web aug 5 2022 sandman çizgi roman tarihine etkisi ve ağırlığı anlamında baktığımız zaman watchmen ve v for vendetta ile benzer bir öneme sahiptir bakalım netflix bu seriyi başarılı bir şekilde ekranlara uyarlayabilecek mi sandman 5 ağustos 2022 de netflix te olacak

sandman vikipedi - May 12 2023

web sandman neil gaiman tarafından yazılıp dc comics tarafından yayımlanan bir çizgi roman serisidir serinin çizerleri arasında sam kieth mike dringenberg jill thompson shawn mcmanus marc hempel ve michael zulli yer alır serinin tüm kapakları dave mckean tarafından tasarlanmıştır 47

[watch the sandman netflix official site](#) - Apr 11 2023

web 2022 maturity rating tv ma 1 season fantasy after years of imprisonment morpheus the king of dreams embarks on a journey across worlds to find what was stolen from him and restore his power starring tom sturridge boyd holbrook patton oswalt

the sandman netflix resmi sitesi - Jul 14 2023

web the sandman 2022 yetişkinlik düzeyi 18 1 sezon fantasy yıllarca süren tutsaklığın ardından düşler kralı morpheus ondan çalınanları bulup gücünü geri kazanmak için dünyalar arasında bir yolculuğa çıkar başroldekiler tom sturridge boyd holbrook patton oswalt binlerce seçenek sınırsız eğlence

[sandman 2 bebek evi sandman 2 cilt amazon com tr](#) - Feb 26 2022

web sandman 2 bebek evi sandman 2 cilt kağıt kapak 1 temmuz 2021 tüm zamanların hem en popüler hem de eleştirmenlerce en çok beğenilen grafik romanlarından biri olan sandman çizgi roman dünyasında olgun ve lirik fantazinin dönüm noktası oldu

[netflix the sandman için sürpriz bir bölüm paylaştı](#) - Mar 30 2022

web aug 19 2022 bunun yerine netflix uyarılama için sürpriz bir yeni bölüm duyurdu bir basın açıklamasıyla duyuran netflix iki bölüm bonus bölümün neil gaiman ın ikonik karanlık fantastik roman serisi the sandman dream country nin üçüncü cildinden hikayeler içereceğini doğruladı

the sandman tv dizisini internetten izleyin justwatch - Feb 09 2023

web gözlerimizi kapatıp uykuya daldığımızda bizi bambaşka bir dünya bekler düşdünya denen bu yerde düşler lordu sandman en derindeki tüm korkularımızı ve fantezilerimizi şekillendirir

netflix in bugüne kadarki en maliyetli dizisi the sandman - Jun 01 2022

web 05 08 2022 17 45 dc dünyası yeni bir diziye imza atıyor Çizgi romanlardan tanıdığımız sandman artık bu çizgi romanlardan çıkıp ekranlarımıza geliyor netflix in tam tamına 165 milyon dolar bütçe ayırdığı the sandman dizisi hakkında bilmeniz gerekenleri bu içeriğimizde yer verdik

[the sandmand dizisi konusu nedir netflix dizisi the sandman](#) - Jul 02 2022

web aug 23 2022 8 ağustos 2022 tarihinde izleyiciyle buluşan netflix in en yüksek bütçeli olan dizisi olarak duyurulan the sandman dizisinin konusu ve oyuncularına ilişkin bilgileri sizler için bu

[the sandman dizi 2022 sinemalar com](#) - Apr 30 2022

web Çağdaş kurgu tarihi dramının kusursuz bir şekilde iç içe geçtiği modern mit ve karanlık fantazinin zengin bir karışımı olan the sandman rüya kralı morpheus tan etkilenen insanları ve yerleri takip ederken onun yaptığı kozmik ve insani hataları anlatıyor

[the sandman rotten tomatoes](#) - Sep 04 2022

web aug 5 2022 when the sandman aka dream the cosmic being who controls all dreams is captured and held prisoner for more than a century he must journey across different worlds and timelines to fix the chaos

[zx35u 3f hitachi construction machinery pdf catalogs](#) - May 13 2023

web catalogs news trends exhibitions zx35u 3f 1 7 pages catalog excerpts zaxis 3 series zero tail swing version f type hydraulic excavator model code zx35u 3f engine rated power 21 3 kw 28 5 hp operating weight 3 520 3 690 kg backhoe bucket 0 11 m3 open the catalog to page 1 wealth of convenient design features

[hitachi zx35u 2 manuals manualslib](#) - Aug 16 2023

web manuals and user guides for hitachi zx35u 2 we have 1 hitachi zx35u 2 manual available for free pdf download operator s manual hitachi zx35u 2 operator s manual 230 pages

hitachi zx35 manuals all things equipment - Jul 03 2022

web hitachi zx35 manuals hitachi zx35 manuals hitachi pay in 4 interest free installments for orders over 50 00 with learn

more manual type parts parts service operators parts service operators price 0 contact us description all manuals are brand new and serial number specific to your exact machine

[hitachi zx35u 2 mini excavator ritchiespecs](#) - Sep 05 2022

web hitachi zx35u 2 mini excavator imperial metric units dimensions boom stick option hex 1 a shipping length of unit 15 26 ft in i max cutting height 16 08 ft in c shipping height of unit 8 08 ft in j max loading height 11 46 ft in l max vertical wall digging depth 8 76 ft in m max digging depth

hitachi zx35u 5a hydraulic excavator workshop manual issuu - Nov 07 2022

web dec 14 2020 this manual consists the technical manual the workshop manual and the engine manual information included in the technical manual technical information needed for redelivery and delivery

hitachi zx27u zx30u zx35u zx40u zx50u hydraulic - Oct 06 2022

web aug 25 2018 complete workshop service manual with electrical wiring diagrams for hitachi zx27u zx30u zx35u zx40u zx50u hydraulic excavator it s the same service manual used by dealers that guaranteed to be fully functional and

[hitachi zx35u 5a workshop manual pdf download](#) - Mar 31 2022

web this hitachi zx35u 5a workshop manual pdf download contains detailed illustrations instructions and diagrams for servicing and repairing your hitachi machine this manual is compatible with all windows and mac operating systems and includes the necessary diagrams and pictures to help guide you through the repair process with this manual

[hitachi zaxis 35u 3 35u 3f excavator service repair manual](#) - Mar 11 2023

web hitachi zaxis 35u 3 35u 3f excavator service repair manual pdf free download as pdf file pdf text file txt or read online for free

hitachi zx35 manual pdf support ortax org - Jan 29 2022

web hitachi zx35 manual pdf free support ortax org created date 9 3 2023 8 10 46 pm

[zx35u 5n hitachi construction machinery americas](#) - Apr 12 2023

web the hitachi zx35u 5n excavator is one you can count on for tough work in close quarters easy to load and transport it s also a smart choice for trenching excavating loading trucks and other jobs in wide open spaces downloads zx35u 5n excavator brochure product highlights advanced hydraulics

zx35u 2 hitachi construction machinery pdf catalogs - Jun 14 2023

web sideplate welding bucket bottom hitachi applied all its excavator expertise in the design of the new zero tail mini excavators zaxis30u 2 and zaxis35u 2 these machines meet customer demands for operating comfort enhanced safety and easier maintenance

[download hitachi excavator zx35u 5a technical manual pdf](#) - Feb 10 2023

web this pdf technical manual is intended for the current repair routine maintenance and troubleshooting of the hitachi hydraulic excavator zx35u 5a model 1 spare part catalogues 2 repair manuals instructions 3 wiring diagrams 4

[hitachi zx30 zx35 zx40 zx50 mini excavator technical](#) - May 01 2022

web hitachi zx30 zx35 zx40 zx50 mini excavator technical repair service manual december 3 2020 yudisie comment 0 information included in this technical manual technical information needed for redelivery and delivery operation and activation of all devices and systems operational performance tests and troubleshooting procedures for

hitachi zx 35 excavator specs 2003 2010 lectura specs - Jun 02 2022

web manufactured by hitachi this is the zx 35 mini excavator find and download detailed specs and data sheets for this machine here equipped with a powerful kubota engine this zx 35 3 19t machine can provide 20kw or 26 horse power for the mini excavator

[hitachi zaxis zx30 zx35 excavator parts catalog manual](#) - Feb 27 2022

web hitachi zaxis zx30 zx35 excavator parts catalog manual parts catalog manual contents appersturcture undercarriage front end attachments etc tools name plate parts index serial number 001001 and up file format total pages 268 size 11mb manual language english please write me if you have questions

hitachi zaxis excavator service manuals and spare parts - Jul 15 2023

web operator s instruction manual 35009011 zx35 hitachi zx35 crawler excavator spare parts catalog service workshop manual operator s instruction manual 35009012 zx35u hitachi zx35u crawler excavator spare parts catalog service workshop manual operator s instruction manual 35009013 zx40 hitachi zx40 crawler

hitachi zx30 zx35 zx40 and zx50 zaxis excavator service manual - Jan 09 2023

web the hitachi zx30 zx35 zx40 and zx50 manual consists of the service manual and the workshop manual information included in the service manual technical information needed for redelivery and delivery operation and activation of all devices and systems operational performance tests and troubleshooting procedures

hitachi zx35 manual pdf full pdf black ortax - Dec 28 2021

web hitachi zx35 manual pdf pages 4 16 hitachi zx35 manual pdf upload jason r murray 4 16 downloaded from black ortax org on september 3 2023 by jason r murray campus program david vizard s how to port and flow test cylinder heads david vizard 2012 porting heads is an art and science it takes a craftsman s

zx35u 2 deere hitachi construction machinery pdf catalogs - Dec 08 2022

web the manual quick coupler makes fast work of bucket and attachment switchovers boom mounted auxiliary hydraulic lines and an auxiliary return flow selector valve accommodate both one and two way hydraulically driven attachments

zx350 7 medium excavator hitachi construction machinery - Aug 04 2022

web about the zx350 7 you can count on the highest quality the ultimate in operating comfort exceptional safety and reduced running costs with the new hitachi zx350 7 medium excavator this versatile model is suitable for a wide range of tasks