

SERVICE DATA

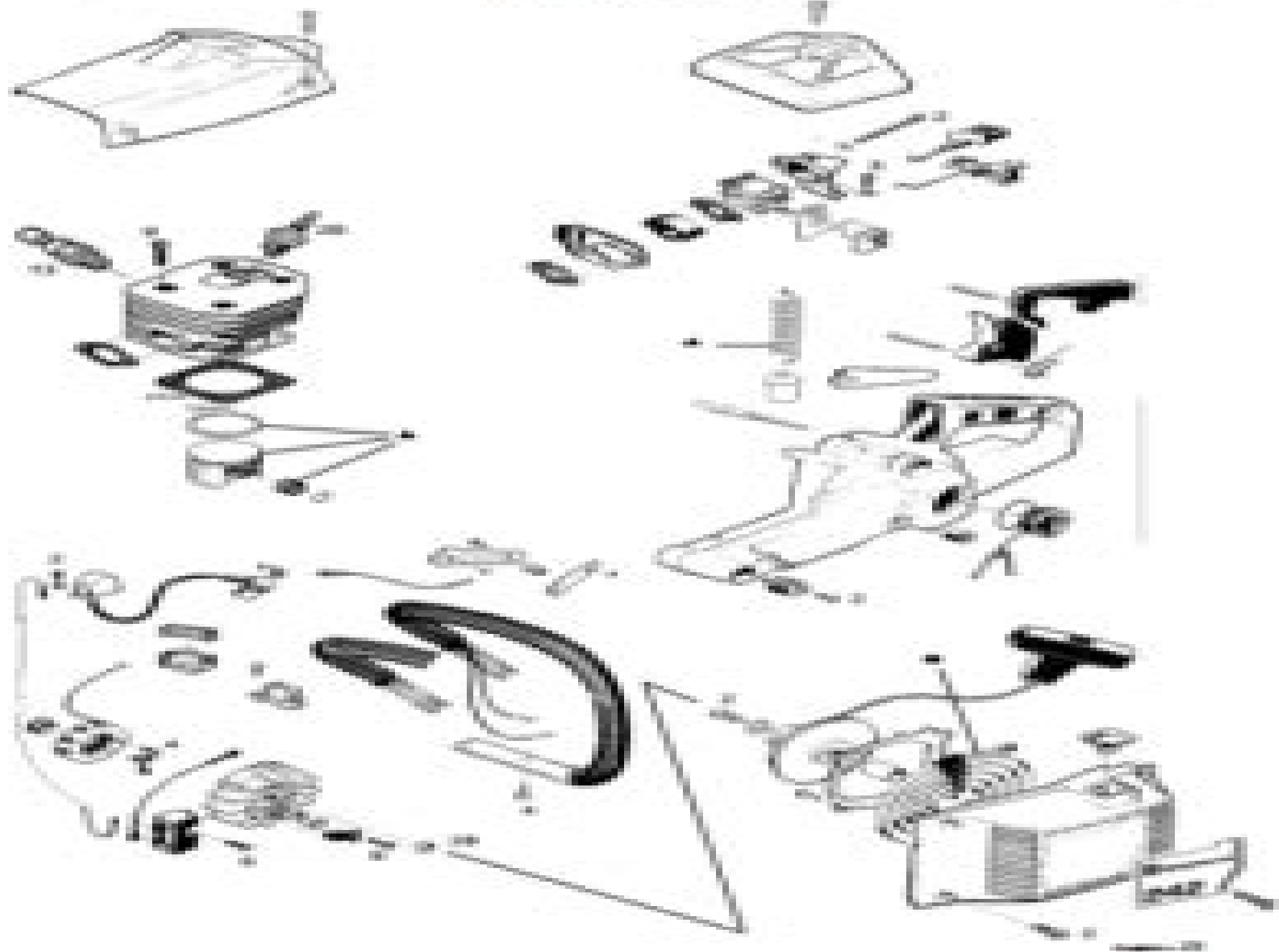

Husqvarna Chainsaw Workshop Repair Manual

M Carnoy



Husqvarna Chainsaw Workshop Repair Manual:

Uncover the mysteries within Explore with is enigmatic creation, Embark on a Mystery with **Husqvarna Chainsaw Workshop Repair Manual** . This downloadable ebook, shrouded in suspense, is available in a PDF format (PDF Size: *). Dive into a world of uncertainty and anticipation. Download now to unravel the secrets hidden within the pages.

https://staging.conocer.cide.edu/About/detail/HomePages/free_stuff_from_the_world_wide_web.pdf

Table of Contents Husqvarna Chainsaw Workshop Repair Manual

1. Understanding the eBook Husqvarna Chainsaw Workshop Repair Manual
 - The Rise of Digital Reading Husqvarna Chainsaw Workshop Repair Manual
 - Advantages of eBooks Over Traditional Books
2. Identifying Husqvarna Chainsaw Workshop Repair Manual
 - Exploring Different Genres
 - Considering Fiction vs. Non-Fiction
 - Determining Your Reading Goals
3. Choosing the Right eBook Platform
 - Popular eBook Platforms
 - Features to Look for in an Husqvarna Chainsaw Workshop Repair Manual
 - User-Friendly Interface
4. Exploring eBook Recommendations from Husqvarna Chainsaw Workshop Repair Manual
 - Personalized Recommendations
 - Husqvarna Chainsaw Workshop Repair Manual User Reviews and Ratings
 - Husqvarna Chainsaw Workshop Repair Manual and Bestseller Lists
5. Accessing Husqvarna Chainsaw Workshop Repair Manual Free and Paid eBooks
 - Husqvarna Chainsaw Workshop Repair Manual Public Domain eBooks
 - Husqvarna Chainsaw Workshop Repair Manual eBook Subscription Services
 - Husqvarna Chainsaw Workshop Repair Manual Budget-Friendly Options
6. Navigating Husqvarna Chainsaw Workshop Repair Manual eBook Formats

- ePub, PDF, MOBI, and More
 - Husqvarna Chainsaw Workshop Repair Manual Compatibility with Devices
 - Husqvarna Chainsaw Workshop Repair Manual Enhanced eBook Features
7. Enhancing Your Reading Experience
 - Adjustable Fonts and Text Sizes of Husqvarna Chainsaw Workshop Repair Manual
 - Highlighting and Note-Taking Husqvarna Chainsaw Workshop Repair Manual
 - Interactive Elements Husqvarna Chainsaw Workshop Repair Manual
 8. Staying Engaged with Husqvarna Chainsaw Workshop Repair Manual
 - Joining Online Reading Communities
 - Participating in Virtual Book Clubs
 - Following Authors and Publishers Husqvarna Chainsaw Workshop Repair Manual
 9. Balancing eBooks and Physical Books Husqvarna Chainsaw Workshop Repair Manual
 - Benefits of a Digital Library
 - Creating a Diverse Reading Collection Husqvarna Chainsaw Workshop Repair Manual
 10. Overcoming Reading Challenges
 - Dealing with Digital Eye Strain
 - Minimizing Distractions
 - Managing Screen Time
 11. Cultivating a Reading Routine Husqvarna Chainsaw Workshop Repair Manual
 - Setting Reading Goals Husqvarna Chainsaw Workshop Repair Manual
 - Carving Out Dedicated Reading Time
 12. Sourcing Reliable Information of Husqvarna Chainsaw Workshop Repair Manual
 - Fact-Checking eBook Content of Husqvarna Chainsaw Workshop Repair Manual
 - Distinguishing Credible Sources
 13. Promoting Lifelong Learning
 - Utilizing eBooks for Skill Development
 - Exploring Educational eBooks
 14. Embracing eBook Trends
 - Integration of Multimedia Elements
 - Interactive and Gamified eBooks

Husqvarna Chainsaw Workshop Repair Manual Introduction

In the digital age, access to information has become easier than ever before. The ability to download Husqvarna Chainsaw Workshop Repair Manual has revolutionized the way we consume written content. Whether you are a student looking for course material, an avid reader searching for your next favorite book, or a professional seeking research papers, the option to download Husqvarna Chainsaw Workshop Repair Manual has opened up a world of possibilities. Downloading Husqvarna Chainsaw Workshop Repair Manual provides numerous advantages over physical copies of books and documents. Firstly, it is incredibly convenient. Gone are the days of carrying around heavy textbooks or bulky folders filled with papers. With the click of a button, you can gain immediate access to valuable resources on any device. This convenience allows for efficient studying, researching, and reading on the go. Moreover, the cost-effective nature of downloading Husqvarna Chainsaw Workshop Repair Manual has democratized knowledge. Traditional books and academic journals can be expensive, making it difficult for individuals with limited financial resources to access information. By offering free PDF downloads, publishers and authors are enabling a wider audience to benefit from their work. This inclusivity promotes equal opportunities for learning and personal growth. There are numerous websites and platforms where individuals can download Husqvarna Chainsaw Workshop Repair Manual. These websites range from academic databases offering research papers and journals to online libraries with an expansive collection of books from various genres. Many authors and publishers also upload their work to specific websites, granting readers access to their content without any charge. These platforms not only provide access to existing literature but also serve as an excellent platform for undiscovered authors to share their work with the world. However, it is essential to be cautious while downloading Husqvarna Chainsaw Workshop Repair Manual. Some websites may offer pirated or illegally obtained copies of copyrighted material. Engaging in such activities not only violates copyright laws but also undermines the efforts of authors, publishers, and researchers. To ensure ethical downloading, it is advisable to utilize reputable websites that prioritize the legal distribution of content. When downloading Husqvarna Chainsaw Workshop Repair Manual, users should also consider the potential security risks associated with online platforms. Malicious actors may exploit vulnerabilities in unprotected websites to distribute malware or steal personal information. To protect themselves, individuals should ensure their devices have reliable antivirus software installed and validate the legitimacy of the websites they are downloading from. In conclusion, the ability to download Husqvarna Chainsaw Workshop Repair Manual has transformed the way we access information. With the convenience, cost-effectiveness, and accessibility it offers, free PDF downloads have become a popular choice for students, researchers, and book lovers worldwide. However, it is crucial to engage in ethical downloading practices and prioritize personal security when utilizing online platforms. By doing so, individuals can make the most of the vast array of free PDF resources available and embark on a journey of continuous learning and intellectual growth.

FAQs About Husqvarna Chainsaw Workshop Repair Manual Books

1. Where can I buy Husqvarna Chainsaw Workshop Repair Manual books? Bookstores: Physical bookstores like Barnes & Noble, Waterstones, and independent local stores. Online Retailers: Amazon, Book Depository, and various online bookstores offer a wide range of books in physical and digital formats.
2. What are the different book formats available? Hardcover: Sturdy and durable, usually more expensive. Paperback: Cheaper, lighter, and more portable than hardcovers. E-books: Digital books available for e-readers like Kindle or software like Apple Books, Kindle, and Google Play Books.
3. How do I choose a Husqvarna Chainsaw Workshop Repair Manual book to read? Genres: Consider the genre you enjoy (fiction, non-fiction, mystery, sci-fi, etc.). Recommendations: Ask friends, join book clubs, or explore online reviews and recommendations. Author: If you like a particular author, you might enjoy more of their work.
4. How do I take care of Husqvarna Chainsaw Workshop Repair Manual books? Storage: Keep them away from direct sunlight and in a dry environment. Handling: Avoid folding pages, use bookmarks, and handle them with clean hands. Cleaning: Gently dust the covers and pages occasionally.
5. Can I borrow books without buying them? Public Libraries: Local libraries offer a wide range of books for borrowing. Book Swaps: Community book exchanges or online platforms where people exchange books.
6. How can I track my reading progress or manage my book collection? Book Tracking Apps: Goodreads, LibraryThing, and Book Catalogue are popular apps for tracking your reading progress and managing book collections. Spreadsheets: You can create your own spreadsheet to track books read, ratings, and other details.
7. What are Husqvarna Chainsaw Workshop Repair Manual audiobooks, and where can I find them? Audiobooks: Audio recordings of books, perfect for listening while commuting or multitasking. Platforms: Audible, LibriVox, and Google Play Books offer a wide selection of audiobooks.
8. How do I support authors or the book industry? Buy Books: Purchase books from authors or independent bookstores. Reviews: Leave reviews on platforms like Goodreads or Amazon. Promotion: Share your favorite books on social media or recommend them to friends.
9. Are there book clubs or reading communities I can join? Local Clubs: Check for local book clubs in libraries or community centers. Online Communities: Platforms like Goodreads have virtual book clubs and discussion groups.
10. Can I read Husqvarna Chainsaw Workshop Repair Manual books for free? Public Domain Books: Many classic books are available for free as they're in the public domain. Free E-books: Some websites offer free e-books legally, like Project Gutenberg or Open Library.

Find Husqvarna Chainsaw Workshop Repair Manual :

~~free stuff from the world wide web~~

~~franz xaver habermann 17211796 ein augsburger ornamentist des rokoko abhandlungen zur geschichte der stadt augsburg~~

~~free-lancer and staff writer newspaper features and magazine articles~~

~~free to care recovery for the whole family~~

francisco de goya

frank capraww ii collection

frankenthaler sanata fe series pastels and other works on paper

franco 1st edition

freddies first night away

francois simiand methode historique et sciences sociales

francis friths around tiverton

~~freddies friends~~

frederick r weisman foundation

frank benson american impressionist

freaky dancin

Husqvarna Chainsaw Workshop Repair Manual :

assessment resources with answer key geometry 2007 - Apr 22 2022

web jan 1 2007 assessment resources with answer key geometry 2007 1st edition assessment resources with answer key geometry 2007 1st edition by inc holt rinehart and winston author 5 0 6 ratings see all formats and editions

chapter 3 resource masters math problem solving - May 04 2023

web glencoe mcgraw hill iv glencoe geometry teacher s guide to using the chapter 3 resource masters the fast filechapter resource system allows you to conveniently file the resources you use most often the chapter 3 resource mastersincludes the core materials needed for chapter 3 these materials include worksheets extensions and

high school geometry khan academy - Mar 02 2023

web learn high school geometry transformations congruence similarity trigonometry analytic geometry and more aligned with common core standards

geometry worksheets math drills - Jul 26 2022

web welcome to the geometry worksheets page at math drills com where we believe that there is nothing wrong with being square this page includes geometry worksheets on angles coordinate geometry triangles quadrilaterals transformations and three dimensional geometry worksheets

geometry textbook solutions answers quizlet - Oct 09 2023

web browse through thousands of step by step solutions to end of chapter questions from the most popular geometry textbooks it s never been a better time to learn get your geometry homework done with quizlet

chapter 1 resource masters - Oct 29 2022

web glencoe mcgraw hill 2 glencoe geometry points lines and planes in space space is a boundless three dimensional set of all points it contains lines and planes a how many planes appear in the figure

unlocking the secrets big ideas learning geometry resources - Jun 24 2022

web the big ideas learning geometry resources by chapter is a comprehensive collection of resources designed to support students in their geometry studies this resource provides answers to the exercises and problems found in each chapter of the big ideas learning geometry textbook

chapter 10 - Mar 22 2022

web sample answer $2n + 1$ $2n + 3$ $2n + 1$ is positive and odd when n is a nonnegative integer the next positive odd integer is $2n + 3$ chapter 10 mathematical practices p 528 1 a and b with radius 3 units and circle c so that it passes through the centers of circles a and b c must be 3 units from a and b so c must lie on an intersection

chapter 1 resource masters - May 24 2022

web the chapter 1 resource masters includes the core materials needed for chapter 1 these materials include worksheets extensions and assessment options the answers for these pages appear at the back of this booklet all of the materials found in this booklet are included for viewing and printing on the teacherworks plus™ cd rom chapter

geometry 1st edition solutions and answers quizlet - Jul 06 2023

web exercise 10c find step by step solutions and answers to geometry 9780395977279 as well as thousands of textbooks so you can move forward with confidence

discovering geometry 5th edition solutions and answers quizlet - Sep 08 2023

web textbook solutions verified chapter 0 geometric art section 0 1 geometry in nature and in art section 0 2 line designs section 0 3 circle designs section 0 4 op art section 0 5 knot designs section 0 6 islamic tile designs page 21 chapter review exercise 1 exercise 2 exercise 3 exercise 4 exercise 5 exercise 6 exercise 7 exercise 8

chapter 1 resource masters math problem solving - Jun 05 2023

web glencoe mcgraw hill iv glencoe geometry teacher s guide to using the chapter 1 resource masters the fast filechapter

resource system allows you to conveniently file the resources you use most often the chapter 1 resource masters includes the core materials needed for chapter 1 these materials include worksheets extensions and

[complete gre geometry review problems and practice prepscholar](#) - Aug 27 2022

web feb 7 2017 answer choice a produces a hypotenuse slightly longer than 4 so this answer is correct too as 3 answer choice c produces a hypotenuse of 5 2 must therefore produce a hypotenuse between 4 12 and 5 and can be marked correct as well so far we know answer choices a b and c are correct now let s solve for answer choice

[get ready for geometry math khan academy](#) - Feb 01 2023

web community questions get ready for high school geometry learn the skills that will set you up for success in congruence similarity and triangle trigonometry analytic geometry conic sections and circles and solid geometry

mcdougal littell geometry answers resources lumos learning - Sep 27 2022

web use the table below to find videos mobile apps worksheets and lessons that supplement mcdougal littell geometry chapter 1 essentials of geometry apps videos practice now lesson 1 identify points lines and planes apps videocam

[chapter 2 resource masters math problem solving](#) - Apr 03 2023

web glencoe mcgraw hill iv glencoe geometry teacher s guide to using the chapter 2 resource masters the fast filechapter resource system allows you to conveniently file the resources you use most often the chapter 2 resource masters includes the core materials needed for chapter 2 these materials include worksheets extensions and

geometry answers and solutions 9th to 10th grade mathleaks - Dec 31 2022

web study smarter not harder with mathleaks improve your math skills using learning focused solutions and answers in geometry 9th and 10th grade mathleaks covers textbooks from publishers such as big ideas learning houghton mifflin harcourt pearson mcgraw hill

[emily kennedy rhs answer keys google sites](#) - Feb 18 2022

web web resources syllabus etc remind101 office hours clubs misc emily kennedy rhs home geometry office hours clubs misc more geo answer keys left the files in these folders give answer keys to quiz and test reviews and some other assignments answer keys left the files in these folders give answer keys to quiz

mcdougal littell geometry resource book answers answers - Nov 29 2022

web apr 28 2022 mcdougal littell geometry resource book answers updated 4 28 2022 wiki user 11y ago study now see answer 1 best answer copy just go to phschool com

[geometry all content khan academy](#) - Aug 07 2023

web math geometry all content unit 1 lines line segments and rays measuring segments parallel and perpendicular points lines planes geometric definitions the golden ratio unit 2 angles angle introduction measuring angles constructing

angles angles in

download omr answer sheets and answer - Sep 04 2022

web download omr answer sheets and answer keys of cbse aipmt re test 2015 soon at

aipmt omr sheet download 2023 2024 student forum ibps omr sheet - Jun 01 2022

web aipmt omr sheet download 2023 2024 get the latest information and updates around aipmt omr sheet download here in influencer one

aipmt answer key 2023 exam with solutions for all sets omr sheet - Aug 15 2023

web feb 4 2023 the answer key will be released in the month of may 2023 tentatively students can access the answer key as a pdf file with the help of the answer key students match their answers and calculate their rough marks aipmt 2023 answer key will be declared on the official website

aipmt omr answer sheet pdf download only - Dec 27 2021

web jul 2 2023 aipmt omr answer sheet pdf right here we have countless ebook aipmt omr answer sheet pdf and collections to check out we additionally allow variant types and moreover type of the books to browse the agreeable book fiction history novel scientific research as skillfully as various further sorts of books are readily approachable

aipmt omr sheet download 2023 2024 student forum - Mar 10 2023

web arihant records for aipmt free read aipmt previous year papers download wb tet answer sheet download aipmt previous year question papers free download ibps omr answer sheet download aipmt admit card download download aipmt papers pdf aipmt applications form aipmt date sheet to download aipmt admit card

omr answer sheets for aipmt uploaded online hindustan times - Jun 13 2023

web the central board of secondary education has uploaded the images of the omr answer sheets of candidates who appeared for the 2014 all india pre medical pre natal entrance test aipmt

aipmt omr sheet sample banking finance gov ie - Mar 30 2022

web aipmt neet 2021 chapter wise and topic wise 15 years solved papers 2006 2020 aipmt omr sheet sample downloaded from banking finance gov ie by guest braxton hayden 32 years neet chapter wise topic wise solved papers physics 2019 1988 14th edition disha publications 15 mock test papers for neet is an authentic and

aipmt 2015 answer key published india today - Jan 08 2023

web may 18 2015 the central board of secondary education cbse has released the aipmt 2015 answer key the images of omr answer sheets and responses to the questions marked by the candidates shall be displayed on may 21 the candidates can challenge the answer key by paying a sum of rs 1 000 per response

aipmt omr answer sheets to be released today india today - Apr 11 2023

web may 28 2014 the aipmt omr answer sheets and responses to the questions marked by the candidates will be displayed by the central board of secondary education cbse today i e may 28 at 3 pm the data will be available till may 31 3 pm on the official website

aipmt 2014 omr answer sheets available by may 25 - Dec 07 2022

web may 18 2014 the aipmt 2014 omr answer sheets will be available online for 5 days most likely from may 25 to may 31 before the declaration of the aipmt results expected in the first week of june 2014 india today

all india pre medical test online registration of candidates - Aug 03 2022

web all india pre medical test online registration of candidates fully online all india pre medical test aipmt facilitates online registration of candidates online payment through payment gateway online issuance of admit card for

[aipmt omr sheet download 2023 2024 grammarlevel com omr](#) - May 12 2023

web nov 16 2019 all india pre medical pre dental entrance test aipmt is a domestic level entrance exam that is organized every year for getting inbound mbbs bds programmes now it is known as neet exam because you want here i am giving below aipmt 2015 omr sheet official answer key on your demand aipmt 2015 omr paper official get

aipmt omr sheet sample 2023 2024 eduvark - Feb 09 2023

web may 20 2015 aipmt omr sheet sample 2023 2024 discuss here about aipmt omr sheet sample and get the latest updates aipmt omr sheet sample detailed information at eduvark

aipmt omr sheet pdf pdf experts - Apr 30 2022

web aug 12 2020 1 32 18 am photos aipmt omr sheet pdf admin august 12 2020 nta will release the neet answer key official images of omr response sheet and test booklet codes of the candidates on may neet omr sheet learn more about omr sheet answer sheet neet exams which were conducted this year have been finally done in a

180 question omr sheet sample omr test sheet - Feb 26 2022

web here we have provided a 180 question omr sheet sample which you can download for free this omr sheet does not have a watermark and can be customized for your institute or organization you can add the name of your institute and logo in the space provided at the top of the sheet

aipmt omr sheet download 2023 2024 370handikap com aipmt omr sheet - Oct 05 2022

web nov 16 2019 if you is looking for information on aipmt omr sheet download then ask your asking is as much details as potential in the reply box provided below which more elaborate your question will be the more easily intention

aipmt 2014 omr answer sheets available india today - Nov 06 2022

web may 28 2014 by indiatoday in aipmt omr answer sheets and responses to the questions marked by the candidates are released and are now available at the official website i e aipmt nic in

aipmt answer key 2020 download ai pmtcode aa bb cc - Jul 02 2022

web nov 28 2020 aipmt answer push 2020 aipmt 2018 is over and now applicants seek aipmt 2020 answer lock available ee fff gg hh the candidates can download and use the aipmt aipmt answer key 2020 aipmt 2018 lives over and now applicants seek aipmt 2020 answer key for sees ff gg hh

mg omr sheets omr sheet manufacture omr answer sheets - Jan 28 2022

web multigraphics group is the first leading largest manufacturer of omr sheets in india supplying worldwide having the clients more than 2000 contains government organizations leading universities institutes colleges schools corporates and public sector units and have the capacity to print 3 0 lacs sheets per day we have a hitech infrastructure with

allen aipmt 2015 answer key paper solutions video solutions - Jul 14 2023

web may 29 2014 aipmt 2015 answer keys paper solutions and video solutions prepared by allen s most experienced talented faculties will be available on 3rd may 2015 after 02 00 pm click on the following links aipmt 2015 answer key aipmt 2015 paper with solution aipmt 2015 video solutions 91 744 515 6100

n4 past papers of human resource mana pdf book - Mar 10 2023

web apr 22 2023 allow below as with ease as review n4 past papers of human resource mana pdf what you bearing in mind to read doing your dissertation in business and

n4 past papers of human resource mana - Dec 07 2022

web n4 past papers of human resource mana this is likewise one of the factors by obtaining the soft documents of this n4 past papers of human resource mana by online you

n4 past papers of human resource mana - Apr 11 2023

web n4 past papers of human resource mana this is likewise one of the factors by obtaining the soft documents of this n4 past papers of human resource mana by online you

diploma in human resource management past papers - Dec 27 2021

web oct 1 2021 foundations of human resource management november 2014 past paper knec diploma foundations of human resource management july 2014 past paper

n4 past papers of human resource mana uniport edu - Sep 23 2021

web n4 past papers of human resource mana 2 7 downloaded from uniport edu ng on april 6 2023 by guest and bibliography resources in women s educational equity 1978

personnel management n4 department of higher - Jul 14 2023

web 4 8 state three objectives of a human resource audit 3 40 question 5 5 1 change is good for any organisation 5 1 1 explain to creative minds management team what

personnel management n4 past papers study guides and - Jan 28 2022

web may 30 2022 find personnel management n4 previous exam question papers with memorandums for answers 2022 2021 2020 2019 and more prescribed textbooks

n4 past papers of human resource mana 2022 - Feb 09 2023

web human resource mana keywords n4 past papers of human resource mana n4 past papers of human resource mana on this page you can read or download human

n4 past papers of human resource mana 2022 - Sep 04 2022

web you could purchase guide n4 past papers of human resource mana or acquire it as soon as feasible you could quickly download this n4 past papers of human resource

n4 past papers of human resource mana pdf pdf vodic - Apr 30 2022

web jul 20 2023 getting the books n4 past papers of human resource mana pdf pdf now is not type of inspiring means you could not lonesome going afterward books heap or

human resource management n4 past exam papers answers - Aug 15 2023

web human resources management n4 n6 ncr tvet college human resources management n4 n6 hrm is a very important function in any organisation that has to

download free n4 past papers of human resource mana - Nov 06 2022

web n4 past papers of human resource mana ssc mts exam 2023 begins today september 1 check shift timings test centre guidelines last minute tips jagran

n4 past papers of human resource mana app webshots com - Jun 01 2022

web title n4 past papers of human resource mana author ads baa uk com 2020 10 05 15 41 08 subject n4 past papers of human resource mana keywords

n4 past papers of human resource mana pdf uniport edu - Jun 13 2023

web papers of human resource mana consequently simple an introduction to human resource management nick wilton 2010 09 15 this exciting new introductory text in

human resource management past exam paper memo s and - Mar 30 2022

web nov 22 2016 human resource management past exam paper memo s and summarized notes course hrm2605 human resource management for line managers

what is n4 human resource management matric college - Oct 05 2022

web apr 14 2022 last updated may 16 2022 n4 human resource management is the first course in the nated human resource management programme this course allows

n4 past papers of human resource mana copy uniport edu - Oct 25 2021

web apr 11 2023 n4 past papers of human resource mana 1 6 downloaded from uniport edu ng on april 11 2023 by guest n4 past papers of human resource mana

n4 past papers of human resource mana pdf uniport edu - May 12 2023

web jun 3 2023 n4 past papers of human resource mana 2 7 downloaded from uniport edu ng on june 3 2023 by guest learning objectives at the outset of every

n4 past papers of human resource mana pdf uniport edu - Nov 25 2021

web mar 4 2023 n4 past papers of human resource mana 1 7 downloaded from uniport edu ng on march 4 2023 by guest n4 past papers of human resource mana

online library n4 past papers of human resource mana read - Jan 08 2023

web sep 4 2023 n4 past papers of human resource mana is available in our book collection an online access to it is set as public so you can get it instantly our book

n4 past papers of human resource mana pdf pdf download - Aug 03 2022

web apr 6 2023 success next door to the message as capably as insight of this n4 past papers of human resource mana pdf pdf can be taken as with ease as picked to act

n4 past papers of human resource mana pdf pdf vodic - Jul 02 2022

web aug 12 2023 message n4 past papers of human resource mana pdf pdf that you are looking for it will definitely squander the time however below later you visit this web

human resource management past examination papers 304 - Feb 26 2022

web sep 28 2022 human resource management past examination papers 304 knec diploma human resource management july 2016 past examination question paper