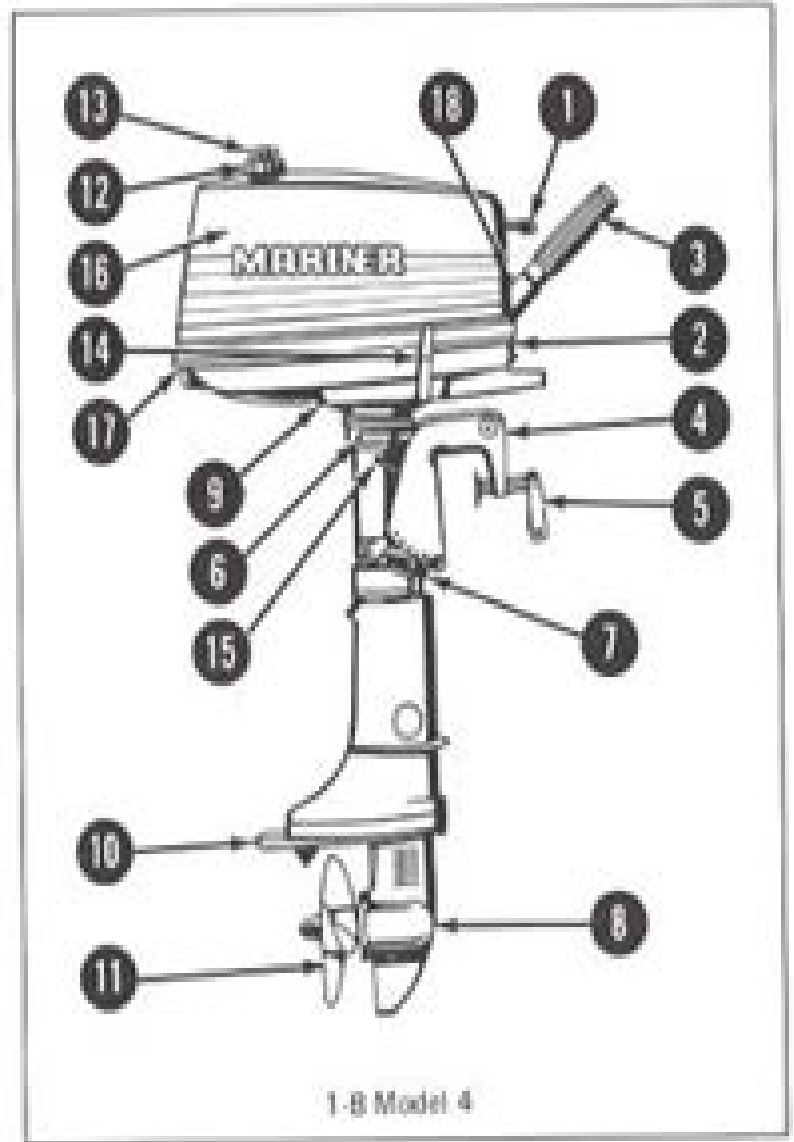
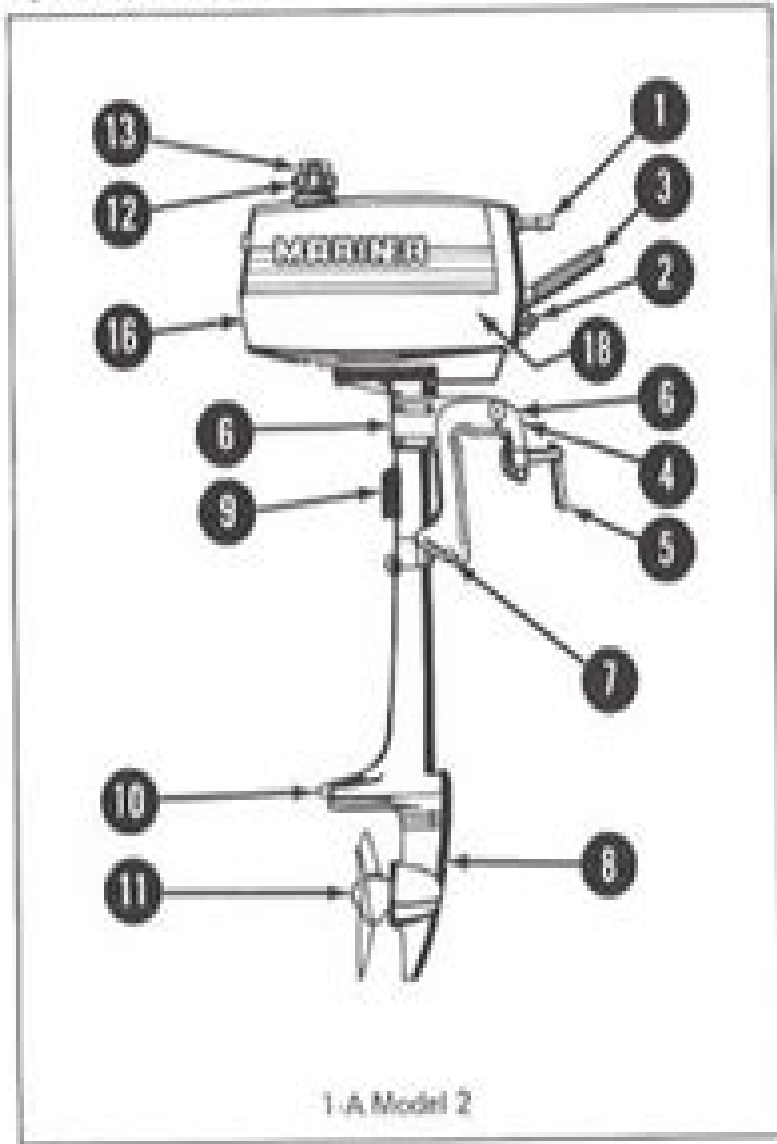

Fig. 1A. Nomenclature



# Mariner 5hp 2 Stroke Outboard Manual

**Sabine Zange**



**Mariner 5hp 2 Stroke Outboard Manual:**

This Enthralling Realm of E-book Books: A Comprehensive Guide Revealing the Advantages of Kindle Books: A Realm of Ease and Flexibility E-book books, with their inherent portability and ease of availability, have liberated readers from the constraints of physical books. Gone are the days of carrying cumbersome novels or carefully searching for particular titles in bookstores. Kindle devices, stylish and lightweight, seamlessly store an wide library of books, allowing readers to immerse in their preferred reads anytime, anywhere. Whether commuting on a bustling train, lounging on a sun-kissed beach, or simply cozying up in bed, E-book books provide an exceptional level of ease. A Literary World Unfolded: Discovering the Wide Array of E-book Mariner 5hp 2 Stroke Outboard Manual Mariner 5hp 2 Stroke Outboard Manual The E-book Store, a virtual treasure trove of literary gems, boasts an wide collection of books spanning diverse genres, catering to every readers taste and choice. From captivating fiction and mind-stimulating non-fiction to timeless classics and modern bestsellers, the E-book Store offers an exceptional variety of titles to discover. Whether looking for escape through engrossing tales of imagination and exploration, delving into the depths of historical narratives, or broadening ones knowledge with insightful works of scientific and philosophy, the Kindle Shop provides a doorway to a literary world brimming with endless possibilities. A Revolutionary Factor in the Bookish Scene: The Enduring Influence of E-book Books Mariner 5hp 2 Stroke Outboard Manual The advent of E-book books has unquestionably reshaped the bookish landscape, introducing a model shift in the way books are released, distributed, and read. Traditional publishing houses have embraced the online revolution, adapting their approaches to accommodate the growing demand for e-books. This has led to a rise in the accessibility of Kindle titles, ensuring that readers have entry to a wide array of bookish works at their fingers. Moreover, Kindle books have equalized entry to literature, breaking down geographical limits and offering readers worldwide with similar opportunities to engage with the written word. Irrespective of their place or socioeconomic background, individuals can now engross themselves in the intriguing world of literature, fostering a global community of readers. Conclusion: Embracing the Kindle Experience Mariner 5hp 2 Stroke Outboard Manual E-book books Mariner 5hp 2 Stroke Outboard Manual, with their inherent ease, versatility, and vast array of titles, have certainly transformed the way we encounter literature. They offer readers the freedom to discover the boundless realm of written expression, anytime, anywhere. As we continue to navigate the ever-evolving digital scene, E-book books stand as testament to the lasting power of storytelling, ensuring that the joy of reading remains accessible to all.

[https://staging.conocer.cide.edu/book/scholarship/default.aspx/jackson\\_s\\_box.pdf](https://staging.conocer.cide.edu/book/scholarship/default.aspx/jackson_s_box.pdf)

## **Table of Contents Mariner 5hp 2 Stroke Outboard Manual**

1. Understanding the eBook Mariner 5hp 2 Stroke Outboard Manual
  - The Rise of Digital Reading Mariner 5hp 2 Stroke Outboard Manual
  - Advantages of eBooks Over Traditional Books
2. Identifying Mariner 5hp 2 Stroke Outboard Manual
  - Exploring Different Genres
  - Considering Fiction vs. Non-Fiction
  - Determining Your Reading Goals
3. Choosing the Right eBook Platform
  - Popular eBook Platforms
  - Features to Look for in an Mariner 5hp 2 Stroke Outboard Manual
  - User-Friendly Interface
4. Exploring eBook Recommendations from Mariner 5hp 2 Stroke Outboard Manual
  - Personalized Recommendations
  - Mariner 5hp 2 Stroke Outboard Manual User Reviews and Ratings
  - Mariner 5hp 2 Stroke Outboard Manual and Bestseller Lists
5. Accessing Mariner 5hp 2 Stroke Outboard Manual Free and Paid eBooks
  - Mariner 5hp 2 Stroke Outboard Manual Public Domain eBooks
  - Mariner 5hp 2 Stroke Outboard Manual eBook Subscription Services
  - Mariner 5hp 2 Stroke Outboard Manual Budget-Friendly Options
6. Navigating Mariner 5hp 2 Stroke Outboard Manual eBook Formats
  - ePub, PDF, MOBI, and More
  - Mariner 5hp 2 Stroke Outboard Manual Compatibility with Devices
  - Mariner 5hp 2 Stroke Outboard Manual Enhanced eBook Features
7. Enhancing Your Reading Experience
  - Adjustable Fonts and Text Sizes of Mariner 5hp 2 Stroke Outboard Manual
  - Highlighting and Note-Taking Mariner 5hp 2 Stroke Outboard Manual
  - Interactive Elements Mariner 5hp 2 Stroke Outboard Manual
8. Staying Engaged with Mariner 5hp 2 Stroke Outboard Manual

- Joining Online Reading Communities
  - Participating in Virtual Book Clubs
  - Following Authors and Publishers Mariner 5hp 2 Stroke Outboard Manual
9. Balancing eBooks and Physical Books Mariner 5hp 2 Stroke Outboard Manual
- Benefits of a Digital Library
  - Creating a Diverse Reading Collection Mariner 5hp 2 Stroke Outboard Manual
10. Overcoming Reading Challenges
- Dealing with Digital Eye Strain
  - Minimizing Distractions
  - Managing Screen Time
11. Cultivating a Reading Routine Mariner 5hp 2 Stroke Outboard Manual
- Setting Reading Goals Mariner 5hp 2 Stroke Outboard Manual
  - Carving Out Dedicated Reading Time
12. Sourcing Reliable Information of Mariner 5hp 2 Stroke Outboard Manual
- Fact-Checking eBook Content of Mariner 5hp 2 Stroke Outboard Manual
  - Distinguishing Credible Sources
13. Promoting Lifelong Learning
- Utilizing eBooks for Skill Development
  - Exploring Educational eBooks
14. Embracing eBook Trends
- Integration of Multimedia Elements
  - Interactive and Gamified eBooks

### **Mariner 5hp 2 Stroke Outboard Manual Introduction**

In the digital age, access to information has become easier than ever before. The ability to download Mariner 5hp 2 Stroke Outboard Manual has revolutionized the way we consume written content. Whether you are a student looking for course material, an avid reader searching for your next favorite book, or a professional seeking research papers, the option to download Mariner 5hp 2 Stroke Outboard Manual has opened up a world of possibilities. Downloading Mariner 5hp 2 Stroke Outboard Manual provides numerous advantages over physical copies of books and documents. Firstly, it is incredibly convenient. Gone are the days of carrying around heavy textbooks or bulky folders filled with papers. With the click of a

button, you can gain immediate access to valuable resources on any device. This convenience allows for efficient studying, researching, and reading on the go. Moreover, the cost-effective nature of downloading Mariner 5hp 2 Stroke Outboard Manual has democratized knowledge. Traditional books and academic journals can be expensive, making it difficult for individuals with limited financial resources to access information. By offering free PDF downloads, publishers and authors are enabling a wider audience to benefit from their work. This inclusivity promotes equal opportunities for learning and personal growth. There are numerous websites and platforms where individuals can download Mariner 5hp 2 Stroke Outboard Manual. These websites range from academic databases offering research papers and journals to online libraries with an expansive collection of books from various genres. Many authors and publishers also upload their work to specific websites, granting readers access to their content without any charge. These platforms not only provide access to existing literature but also serve as an excellent platform for undiscovered authors to share their work with the world. However, it is essential to be cautious while downloading Mariner 5hp 2 Stroke Outboard Manual. Some websites may offer pirated or illegally obtained copies of copyrighted material. Engaging in such activities not only violates copyright laws but also undermines the efforts of authors, publishers, and researchers. To ensure ethical downloading, it is advisable to utilize reputable websites that prioritize the legal distribution of content. When downloading Mariner 5hp 2 Stroke Outboard Manual, users should also consider the potential security risks associated with online platforms. Malicious actors may exploit vulnerabilities in unprotected websites to distribute malware or steal personal information. To protect themselves, individuals should ensure their devices have reliable antivirus software installed and validate the legitimacy of the websites they are downloading from. In conclusion, the ability to download Mariner 5hp 2 Stroke Outboard Manual has transformed the way we access information. With the convenience, cost-effectiveness, and accessibility it offers, free PDF downloads have become a popular choice for students, researchers, and book lovers worldwide. However, it is crucial to engage in ethical downloading practices and prioritize personal security when utilizing online platforms. By doing so, individuals can make the most of the vast array of free PDF resources available and embark on a journey of continuous learning and intellectual growth.

### FAQs About Mariner 5hp 2 Stroke Outboard Manual Books

**What is a Mariner 5hp 2 Stroke Outboard Manual PDF?** A PDF (Portable Document Format) is a file format developed by Adobe that preserves the layout and formatting of a document, regardless of the software, hardware, or operating system used to view or print it. **How do I create a Mariner 5hp 2 Stroke Outboard Manual PDF?** There are several ways to create a PDF: Use software like Adobe Acrobat, Microsoft Word, or Google Docs, which often have built-in PDF creation

tools. Print to PDF: Many applications and operating systems have a "Print to PDF" option that allows you to save a document as a PDF file instead of printing it on paper. Online converters: There are various online tools that can convert different file types to PDF. **How do I edit a Mariner 5hp 2 Stroke Outboard Manual PDF?** Editing a PDF can be done with software like Adobe Acrobat, which allows direct editing of text, images, and other elements within the PDF. Some free tools, like PDFescape or Smallpdf, also offer basic editing capabilities. **How do I convert a Mariner 5hp 2 Stroke Outboard Manual PDF to another file format?** There are multiple ways to convert a PDF to another format: Use online converters like Smallpdf, Zamzar, or Adobe Acrobats export feature to convert PDFs to formats like Word, Excel, JPEG, etc. Software like Adobe Acrobat, Microsoft Word, or other PDF editors may have options to export or save PDFs in different formats. **How do I password-protect a Mariner 5hp 2 Stroke Outboard Manual PDF?** Most PDF editing software allows you to add password protection. In Adobe Acrobat, for instance, you can go to "File" -> "Properties" -> "Security" to set a password to restrict access or editing capabilities. Are there any free alternatives to Adobe Acrobat for working with PDFs? Yes, there are many free alternatives for working with PDFs, such as: LibreOffice: Offers PDF editing features. PDFsam: Allows splitting, merging, and editing PDFs. Foxit Reader: Provides basic PDF viewing and editing capabilities. How do I compress a PDF file? You can use online tools like Smallpdf, ILovePDF, or desktop software like Adobe Acrobat to compress PDF files without significant quality loss. Compression reduces the file size, making it easier to share and download. Can I fill out forms in a PDF file? Yes, most PDF viewers/editors like Adobe Acrobat, Preview (on Mac), or various online tools allow you to fill out forms in PDF files by selecting text fields and entering information. Are there any restrictions when working with PDFs? Some PDFs might have restrictions set by their creator, such as password protection, editing restrictions, or print restrictions. Breaking these restrictions might require specific software or tools, which may or may not be legal depending on the circumstances and local laws.

### Find Mariner 5hp 2 Stroke Outboard Manual :

[jackson s box](#)

[ja economics answer key](#)

[j567 03 mark scheme february 2013](#)

**james rachels the elements of moral philosophy 7th edition**

[james hored leveling guide](#)

**jacuzzi espreo owners manual**

[jackson hole visitor guide](#)

**james stewart solutions manual**



[james s walker physics 4th edition solutions chapter 9](#)

**jaguar xjs 1983 service manual**

[jaguar e type workshop manual 1961 1970](#)

**jambalaya seasoning mix recipe**

[james stewart essential calculus solutions even problems](#)

[jaeger microelectronics circuit design 4th solution](#)

[jaguar x type workshop manual](#)

## **Mariner 5hp 2 Stroke Outboard Manual :**

**messages from the masters weiss dr brian** - Apr 07 2023

web 10 days from delivery replacement messages from the masters goes beyond his previous bestsellers it draws on dr weiss s fascinating case histories and the wisdom of his spirit guides to help you bring joy balance and harmony into your life

[messages from the masters tapping into the power of love](#) - Oct 13 2023

web apr 1 2001 messages from the masters tapping into the power of love weiss md brian on amazon com free shipping on qualifying offers messages from the masters tapping into the power of love

**messages from the masters tapping into the power of love** - Aug 31 2022

web messages from the masters tapping into the power of love weiss brian l brian leslie 1944 free download borrow and streaming internet archive

[messages from the masters tapping into the power of love](#) - Feb 05 2023

web apr 1 2001 messages from the masters is a surprisingly beautiful book that although conveyed intellectually is truly remarkable in it s simplicity the book unfolds beautifully until it has a similar impact to sogyal rinpoche s the tibetan book of living and dying

**messages from the masters tapping into the power of love** - Nov 02 2022

web apr 1 2001 the book that sheds new light on reincarnation and the extraordinary healing potential of past life and hypnotic regression therapy from the bestselling author of many lives many masters brian see details

**messages from the masters tapping into the power of love** - Apr 26 2022

web a leader in the new age movement dr brian weiss is famous for his work on past life regression now after two decades of studying reincarnation weiss has discovered the ultimate healing energy love not love in a romantic sense but love as the life force an actual physical energy that can be measured in this important work weiss addresses

[messages from the masters tapping into the power of love](#) - Mar 06 2023

web messages from the masters is the ultimate guidebook to understanding the purpose and the fullness of who you are embrace and discover the eternal healing elements of love through the gentle wisdom of one of the world s most enlightened teachers

**messages from the masters quotes by brian l weiss goodreads** - Jun 09 2023

web messages from the masters tapping into the power of love by brian l weiss 5 714 ratings 4 34 average rating 240 reviews messages from the masters quotes showing 1 30 of 49 forgive the past it is over learn from it and let go people are constantly changing and growing

*messages from the masters brian l weiss md* - Jul 10 2023

web messages from the masters is the ultimate guidebook to understanding the purpose and the fullness of who you are embrace and discover the eternal healing elements of love through the gentle wisdom of one of the world s most enlightened teachers

*messages from the masters tapping into the power of love* - May 08 2023

web oct 30 2008 messages from the masters is the ultimate guidebook to understanding the purpose and the fullness of who you are embrace and discover the eternal healing elements of love through the gentle wisdom of one of the world s most enlightened teachers

messages from the masters pages 1 50 flip pdf download - Jun 28 2022

web may 6 2015 check pages 1 50 of messages from the masters in the flip pdf version messages from the masters was published by ashlesha dhaundiyal on 2015 05 06 find more similar flip pdfs like messages from the masters download messages from the masters pdf for free

**messages from the masters tapping into the power of love** - Dec 03 2022

web nov 16 2008 messages from the masters tapping into the power of love brian weiss grand central publishing nov 16 2008 psychology 224 pages in many lives many masters brian weiss opened an

**messages from the masters by brian l weiss open library** - Feb 22 2022

web feb 28 2023 overview view 4 editions details reviews lists related books last edited by importbot february 28 2023 history edit an edition of messages from the masters 2000 messages from the masters tapping into the power of love by brian l weiss 5 00 1 rating 36 want to read 3 currently reading 3 have read

*message from the masters archives spirit release energy* - Mar 26 2022

web nov 7 2023 message from the masters new moon celestial gathering october 14 2023 greetings dear ones it is with great pleasure that we commune with you at this time we know there is much turbulence in the world that is of growing concern to most of you we wish to remind you to stay within your own circle of family friends acquaintances and

*messages from the masters tapping into the power of love* - Oct 01 2022

web messages from the masters tapping into the power of love brian l weiss warner books 22 95 272pp isbn 978 0 446 52596 1

**messages from the masters tapping into the power of love google play** - Jan 04 2023

web messages from the masters tapping into the power of love ebook written by brian weiss read this book using google play books app on your pc android ios devices download for offline reading highlight bookmark or take notes while you read messages from the masters tapping into the power of love

**messages from the masters tapping into the power of love goodreads** - Aug 11 2023

web jan 1 1999 messages from the masters tapping into the power of love brian l weiss 4 33 5 717 ratings240 reviews the true story of a prominent psychiatrist his young patient and the past life therapy that changed both their lives

messages from the masters tapping into the power of love - May 28 2022

web messages from the masters tapping into the power of love weiss dr brian amazon sg books

messages from the master find the master within - Jul 30 2022

web welcome to messages from the masters channeled messages from the master lord emanuel and the collective responsible for the great plan to return all of humanity to christ consciousness direct transmissions via video messages and written transcripts below

*messages from the masters brian weiss archive org* - Sep 12 2023

web oct 17 2020 publication date 2000 topics psychiatry weiss messages spiritual collection opensource language english from the author of the international bestseller many lives many masters comes a spiritual guidebook that shows you how to capture the healing energy of love

**management information systems lecture notes lectures 1 12** - May 12 2023

web management information systems lecture notes lectures 1 12 information systems business studocu detailed summary of all chapters and lectures covered throughout the course information systems business strategy information systems is any tool that people skip to document ask ai

*laudon mis16 ppt ch10 kl ce updated content for* - Feb 26 2022

web laudon mis16 ppt ch10 kl ce updated content for 2021 e commerce digital markets digital goods 1 1 view presentation slides online mis lecture notes chapter 10

**mis module 3 lecture notes pdf decision support system** - Apr 30 2022

web mis module 3 lecture notes free download as pdf file pdf text file txt or view presentation slides online mis module 2

*mis lecture notes dr muchelule* - Jun 13 2023

web meaning of mis 1 what is a system in the context of mis an inputs processing output and feedback matrix supports the processing of data into information 1 2 objectives of mis mis processes data to support the management functions mis manages information system is productively

**laudon mis16 ppt ch11 kl ce updated content for** - Jan 28 2022

web laudon mis16 ppt ch11 kl ce updated content for 2021 managing knowledge and artificial intelligence 3 1 view presentation slides online mis lecture notes chapter 11

**introduction management information system lecture notes** - Sep 04 2022

web in order to provide past present and prediction information an mis can include software that helps in decision making data resources such as databases the hardware resources of a system decision support systems people management and project management applications and any computerized processes that enable the department to run

*mis lecture note pdf document* - Apr 11 2023

web nov 3 2015 mis lecture note 8 mis lecture 06 mis lecture 6 mis lecture lengthscales mis 648 lecture 81 mis 648

presentation notes lecture 8 global aspects of e commerce mis lecture 2 mis lecture microfab softlitho mis 648 lecture 141

mis 648 presentation notes lecture 14 selecting offshoring sites

management information system full notes slideshare - Mar 10 2023

web feb 29 2016 lecture handout on management information system mis for the program bim seventh semester tribhuvan university specially for my students of prime college nayabazar nccs pakanajol asian school of management and technology gongabu and cab naxal dear students this note is just class handouts

**management information systems mis** - Jul 14 2023

web lecture 8 information systems what are information systems 1 information another definition an increment in knowledge information relies on the context of the question general knowledge of the recipient 2 informal information interpersonal networking note informal information and other information

management information systems mis - Aug 03 2022

web the paper has to be sent by e mail with the subject mis study your names in an editable form and in a pdf form you will receive a feedback additional changes might be ask which have to be done till the exam day the study has to be re sent by e mail till the exam day references management information systems managing the digital

**chapter 01 lecture notes mis 3301 studocu** - Oct 05 2022

web chapter 01 lecture notes mis 3301 management information systems 16e laudon amp laudon lecture studocu

management information systems 16e laudon laudon lecture files barbara ellestad chapter information systems in global business today computers are changing skip to document ask ai

[mis pdf lecture notes 1 20 studocu](#) - Feb 09 2023

web as indicated by its name 2 nd definition a management information system mis is an information system used for decision making and for the coordination control analysis

**mit opencourseware free online course materials** - Dec 07 2022

web free lecture notes exams and videos from mit no registration required learn more about the ocw mission

**basic concepts of mis management information system lecture notes** - Jul 02 2022

web basic concepts of mis management information system lecture notes docsity earn on docsity study with the several resources on docsity prepare for your exams with the study notes shared by other students like you on docsity

**mis nedir ışık Üniversitesi** - Dec 27 2021

web mis öğrencileri bu hedefe dönük olarak bilgisayar internet ve bilgi yönetimi konularında dersler alırlar mis programımız içinde verilen derslerin bir kısmı şu şekildedir veritabanı ve yönetimi bilgisayar ağları ve bilgi güvenliği veri madenciliği web tasarımı ve elektronik ticaret mobil programlama İş ve süreç

**mis lecture notes 1 transaction processing system studocu** - Jun 01 2022

web transaction processing system introduction about tps mis primarily provides information to help the managers in monitoring and controlling the business activities with help of tps mis reports and summaries can possible with tps mis reports can be generated on demand with back support of tps

**management information system notes pdf mba 2023** - Jan 08 2023

web dec 11 2019 download pdf it will help you to understand question paper pattern and type of management information system question and answer asked in bba bcom mcom mba management information system exam you can download the syllabus in management information system pdf form

**management information system tutorial online tutorials library** - Mar 30 2022

web resources management information system mis is a planned system of collecting storing and disseminating data in the form of information needed to carry out the functions of management this tutorial covers the concepts related to information and provides a detailed coverage on mis and other major enterprise level systems

*lecture notes for management information systems for docsity* - Aug 15 2023

web looking for lecture notes in management information systems download now thousands of lecture notes in management information systems on docsity lecture notes for management information systems management free online as pdf docsity

[mis 214 lecture notes california state university sacramento](#) - Nov 06 2022

web mis 214 lecture notes chapter 1 chapter 2 chapter 3 chapter 4 chapter 5 chapter 6 chapter 7 chapter 8 chapter 9 chapter 10 chapter 11 chapter 12 chapter 13 chapter 14 chapter 15 chapter 16 exam

**chambering rifles for accuracy by fred zeglin** - Jun 11 2023

web chambering rifles for accuracy written for the serious gunsmithing student this book discusses several methods that can be used to accurately chamber a rifle barrel along with some tricks of the trade that will improve your results

**pdf download chambering rifles for accuracy gunsmithing student** - Dec 05 2022

web apr 9 2020 business account series gunsmithing student handbook series book 3 paperback 124 pages publisher 4d reamer rentals ltd february 28 2018 language english isbn 10 0983159858 isbn 13 978 0983159858 product dimensions 5 5 x 0 3 x 8 5 inches step by step to download or read online 1

*chambering rifles for accuracy 3 gunsmithing student* - May 10 2023

web titles include understanding headspace chambering for ackley cartridges relining barrels glass bedding rifles for stability and accuracy and chambering rifle barrels for accuracy look for other books in the gunsmithing student handbook series gordy gritters is a professional gunsmith who has been gunsmithing since 1987

*indoor air weapons range membership rates safra* - Mar 28 2022

web membership 64 60 162 50 162 50 108 00 air weapon safety course chargeable per discipline air pistol air rifle 50 75

**chambering rifles for accuracy gunsmithing student handbook** - Feb 07 2023

web sep 22 2023 chambering rifles for accuracy gunsmithing student handbook 3 new condition new price us 57 95 buy it now add to cart add to watchlist shipping us 4 79economy shipping see details located in houston texas united states delivery estimated between mon oct 2 and fri oct 6 to 23917 returns seller does not accept

**htx marksmen in the making with smart training technology** - Sep 02 2022

web the enhanced live firing range system elfras developed by the htx human factors and simulation centre of expertise and the singapore police force uses sensors and analytics to improve the shooting accuracy of those taking the test the system not only provides information on the grouping of shots but also does real time analysis of human

**chambering rifles for accuracy fred zeglin gordy gritters** - Mar 08 2023

web feb 28 2018 gordy gritters is a professional gunsmith who has been gunsmithing since 1987 his business was in pella iowa from 1987 until he moved his shop to kansas city mo in 2011 he has done a lot of general gunsmithing repairs refinishing and rebluing over the years but his primary focus all these years has been on accurizing factory rifles

**pdf read chambering rifles for accuracy 3 gunsmithing student** - Nov 04 2022

web sep 1 2021 view flipping ebook version of pdf read chambering rifles for accuracy 3 gunsmithing student handbook published by jailen markos on 2021 09 01 interested in flipbooks about pdf read chambering rifles for accuracy 3 gunsmithing student handbook check more flip ebooks related to pdf read

**chambering rifles for accuracy 3 gunsmithing student handbook** - Apr 09 2023

web titles include understanding headspace chambering for ackley cartridges relining barrels glass bedding rifles for stability and accuracy and chambering rifle barrels for accuracy look for other books in the gunsmithing student handbook series gordy gritters is a professional gunsmith who has been gunsmithing since 1987

*chambering rifles for accuracy gunsmithing student full pdf* - Jan 06 2023

web chambering rifles for accuracy gunsmithing student the sporting rifle and its projectiles dec 18 2021 total gun manual field stream feb 05 2021 shares insider hints stories from the range and field and hands on guidance for the first time gun owner and the seasoned veteran alike offering advice on choosing the right gun increasing

**chambering rifles for accuracy 3 gunsmithing student** - Oct 15 2023

web feb 28 2018 titles include understanding headspace chambering for ackley cartridges relining barrels glass bedding rifles for stability and accuracy and chambering rifle barrels for accuracy look for other books in the gunsmithing student handbook series gordy gritters is a professional gunsmith who has been

higher caliber asian military review - May 30 2022

web may 20 2021 the rifle weight is 3 25kg 7 2 lb with overall length of 745mm 29 3in its integrated carrying handle has mounting fixtures to accept a y ma95 002 telescopic sight with selective fire including full automatic the weapon was designed around and to optimise the accuracy and performance of the 5 8x42mm caliber

*read free chambering rifles for accuracy gunsmithing student* - Aug 01 2022

web chambering rifles for accuracy gunsmithing student wildcat cartridges jul 04 2022 the reloader s handbook of wildcat cartridge design is a must have for all shooters regardless of their experience for the hunter with one gun or collector with many you will find valuable information on accuracy designing building loading and shooting

guns in singapore firearms gun law and gun control - Apr 28 2022

web in singapore civilian possession of rifles and shotguns is regulated by law 64 compare gun ownership and possession in singapore only licensed gun owners 23 66 67 64 may lawfully acquire possess or transfer a firearm or ammunition compare genuine reason required for firearm possession

*read e book chambering rifles for accuracy gunsmithing student* - Oct 03 2022

web attention your epaper is waiting for publication by publishing your document the content will be optimally indexed by google via ai and sorted into the right category for over 500 million epaper readers on yumpu

chambering rifles for accuracy gunsmithing student handbook - Jul 12 2023

web extreme accuracy institute and gordy s precision gunsmithing student handbook ser chambering rifle gunsmithing student handbook series 4d reamer rentals pin on guns chambering rifles for accuracy gunsmithing student chambering for ackley

**chambering rifles for accuracy gunsmithing student** - Jun 30 2022

web 2 chambering rifles for accuracy gunsmithing student 2021 11 09 chambering rifles for accuracy gunsmithing student downloaded from store spiralny com by guest mariana demarion understanding headspace simon and schuster this book takes the reader through 195 pages and loads of photos of accurizing the classic remington 700

**gunsmithing student handbook series chambering rifles for accuracy** - Aug 13 2023

web apr 4 2018 chambering rifles for accuracy chambering rifles for accuracy by fred zeglin gordy gritters isbn 13 978 0 9831598 5 8 price 39 95 softcover 5 50 x 8 5 123 pages in part i of

**fred zeglin gunsmithing student handbook series** - Sep 14 2023

web chambering rifles for accuracy written for the serious gunsmithing student this book discusses several methods that can be used to accurately chamber a rifle barrel along with some tricks of the trade that will improve your results on day one learn more

*chambering rifles for accuracy gunsmithing student handbook* - Feb 24 2022

web rifles gunsmithing ebay chambering riflshooter gunsmithing student handbook series chambering rifles pin on guns ar 15 best sites about rifle chambering dies rental chambering a rifle barrel understanding headspace gunsmithing student handbook chambering rifles for accuracy by fred zeglin gordy chambering rifles for accuracy