

Item	Description	Page
1	Water Pump Indicator	11
2	Trimming Tilt Switch	11
3	Tilt Support Lever	11
4	Adjustment Knobs	11
5	Tilt Tab	26, 27
6	Propeller (not supplied)	26, 27
7	Adjustment Screw of S. Plug	26

Item	Description	Page
8	Water Intake	11
9	Adjustment Level Plug	11
10	Power Trim Tilt Pedestal	11
11	Tilt Lock Switch	11
12	Power Switch	11
13	Remote Control	11
14	Cleat and Lanyard Assembly	11

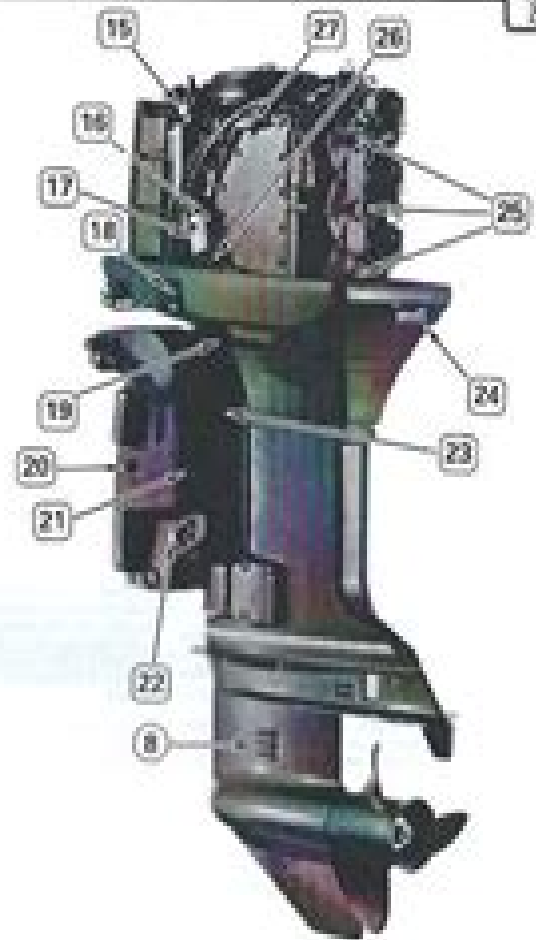

Item	Description	Page
15	Water Pump Filter	11
16	Water Pump Filter	11
17	Water Pump Filter	11
18	Water Pump Filter	11
19	Water Pump Filter	11
20	Water Pump Filter	11
21	Water Pump Filter	11
22	Water Pump Filter	11
23	Water Pump Filter	11
24	Water Pump Filter	11
25	Water Pump Filter	11
26	Water Pump Filter	11
27	Water Pump Filter	11
28	Water Pump Filter	11

Item	Description	Page
1	Oil Control Valve	11
2	Model and Serial Number Plate	11
3	Engine Cover Latch	11
4	Spark Plug	11
5	Water Pressure Tap	11
6	Fuel	11

Johnson 70 Hp Manual

Lingjun Ying



Johnson 70 Hp Manual:

This is likewise one of the factors by obtaining the soft documents of this **Johnson 70 Hp Manual** by online. You might not require more era to spend to go to the ebook launch as without difficulty as search for them. In some cases, you likewise pull off not discover the declaration Johnson 70 Hp Manual that you are looking for. It will entirely squander the time.

However below, when you visit this web page, it will be appropriately unconditionally simple to acquire as without difficulty as download lead Johnson 70 Hp Manual

It will not receive many time as we notify before. You can realize it though proceed something else at home and even in your workplace. so easy! So, are you question? Just exercise just what we come up with the money for below as with ease as review **Johnson 70 Hp Manual** what you in imitation of to read!

<https://staging.conocer.cide.edu/About/browse/index.jsp/mapping%20gender%20in%20ancient%20religious%20discourses.pdf>

Table of Contents Johnson 70 Hp Manual

1. Understanding the eBook Johnson 70 Hp Manual
 - The Rise of Digital Reading Johnson 70 Hp Manual
 - Advantages of eBooks Over Traditional Books
2. Identifying Johnson 70 Hp Manual
 - Exploring Different Genres
 - Considering Fiction vs. Non-Fiction
 - Determining Your Reading Goals
3. Choosing the Right eBook Platform
 - Popular eBook Platforms
 - Features to Look for in an Johnson 70 Hp Manual
 - User-Friendly Interface
4. Exploring eBook Recommendations from Johnson 70 Hp Manual

- Personalized Recommendations
- Johnson 70 Hp Manual User Reviews and Ratings
- Johnson 70 Hp Manual and Bestseller Lists
- 5. Accessing Johnson 70 Hp Manual Free and Paid eBooks
 - Johnson 70 Hp Manual Public Domain eBooks
 - Johnson 70 Hp Manual eBook Subscription Services
 - Johnson 70 Hp Manual Budget-Friendly Options
- 6. Navigating Johnson 70 Hp Manual eBook Formats
 - ePub, PDF, MOBI, and More
 - Johnson 70 Hp Manual Compatibility with Devices
 - Johnson 70 Hp Manual Enhanced eBook Features
- 7. Enhancing Your Reading Experience
 - Adjustable Fonts and Text Sizes of Johnson 70 Hp Manual
 - Highlighting and Note-Taking Johnson 70 Hp Manual
 - Interactive Elements Johnson 70 Hp Manual
- 8. Staying Engaged with Johnson 70 Hp Manual
 - Joining Online Reading Communities
 - Participating in Virtual Book Clubs
 - Following Authors and Publishers Johnson 70 Hp Manual
- 9. Balancing eBooks and Physical Books Johnson 70 Hp Manual
 - Benefits of a Digital Library
 - Creating a Diverse Reading Collection Johnson 70 Hp Manual
- 10. Overcoming Reading Challenges
 - Dealing with Digital Eye Strain
 - Minimizing Distractions
 - Managing Screen Time
- 11. Cultivating a Reading Routine Johnson 70 Hp Manual
 - Setting Reading Goals Johnson 70 Hp Manual
 - Carving Out Dedicated Reading Time
- 12. Sourcing Reliable Information of Johnson 70 Hp Manual

- Fact-Checking eBook Content of Johnson 70 Hp Manual
 - Distinguishing Credible Sources
13. Promoting Lifelong Learning
- Utilizing eBooks for Skill Development
 - Exploring Educational eBooks
14. Embracing eBook Trends
- Integration of Multimedia Elements
 - Interactive and Gamified eBooks

Johnson 70 Hp Manual Introduction

In today's digital age, the availability of Johnson 70 Hp Manual books and manuals for download has revolutionized the way we access information. Gone are the days of physically flipping through pages and carrying heavy textbooks or manuals. With just a few clicks, we can now access a wealth of knowledge from the comfort of our own homes or on the go. This article will explore the advantages of Johnson 70 Hp Manual books and manuals for download, along with some popular platforms that offer these resources. One of the significant advantages of Johnson 70 Hp Manual books and manuals for download is the cost-saving aspect. Traditional books and manuals can be costly, especially if you need to purchase several of them for educational or professional purposes. By accessing Johnson 70 Hp Manual versions, you eliminate the need to spend money on physical copies. This not only saves you money but also reduces the environmental impact associated with book production and transportation. Furthermore, Johnson 70 Hp Manual books and manuals for download are incredibly convenient. With just a computer or smartphone and an internet connection, you can access a vast library of resources on any subject imaginable. Whether you're a student looking for textbooks, a professional seeking industry-specific manuals, or someone interested in self-improvement, these digital resources provide an efficient and accessible means of acquiring knowledge. Moreover, PDF books and manuals offer a range of benefits compared to other digital formats. PDF files are designed to retain their formatting regardless of the device used to open them. This ensures that the content appears exactly as intended by the author, with no loss of formatting or missing graphics. Additionally, PDF files can be easily annotated, bookmarked, and searched for specific terms, making them highly practical for studying or referencing. When it comes to accessing Johnson 70 Hp Manual books and manuals, several platforms offer an extensive collection of resources. One such platform is Project Gutenberg, a nonprofit organization that provides over 60,000 free eBooks. These books are primarily in the public domain, meaning they can be freely distributed and downloaded. Project Gutenberg offers a wide range of classic literature, making it an excellent resource for literature enthusiasts. Another popular platform for Johnson 70 Hp Manual

books and manuals is Open Library. Open Library is an initiative of the Internet Archive, a non-profit organization dedicated to digitizing cultural artifacts and making them accessible to the public. Open Library hosts millions of books, including both public domain works and contemporary titles. It also allows users to borrow digital copies of certain books for a limited period, similar to a library lending system. Additionally, many universities and educational institutions have their own digital libraries that provide free access to PDF books and manuals. These libraries often offer academic texts, research papers, and technical manuals, making them invaluable resources for students and researchers. Some notable examples include MIT OpenCourseWare, which offers free access to course materials from the Massachusetts Institute of Technology, and the Digital Public Library of America, which provides a vast collection of digitized books and historical documents. In conclusion, Johnson 70 Hp Manual books and manuals for download have transformed the way we access information. They provide a cost-effective and convenient means of acquiring knowledge, offering the ability to access a vast library of resources at our fingertips. With platforms like Project Gutenberg, Open Library, and various digital libraries offered by educational institutions, we have access to an ever-expanding collection of books and manuals. Whether for educational, professional, or personal purposes, these digital resources serve as valuable tools for continuous learning and self-improvement. So why not take advantage of the vast world of Johnson 70 Hp Manual books and manuals for download and embark on your journey of knowledge?

FAQs About Johnson 70 Hp Manual Books

1. Where can I buy Johnson 70 Hp Manual books? Bookstores: Physical bookstores like Barnes & Noble, Waterstones, and independent local stores. Online Retailers: Amazon, Book Depository, and various online bookstores offer a wide range of books in physical and digital formats.
2. What are the different book formats available? Hardcover: Sturdy and durable, usually more expensive. Paperback: Cheaper, lighter, and more portable than hardcovers. E-books: Digital books available for e-readers like Kindle or software like Apple Books, Kindle, and Google Play Books.
3. How do I choose a Johnson 70 Hp Manual book to read? Genres: Consider the genre you enjoy (fiction, non-fiction, mystery, sci-fi, etc.). Recommendations: Ask friends, join book clubs, or explore online reviews and recommendations. Author: If you like a particular author, you might enjoy more of their work.
4. How do I take care of Johnson 70 Hp Manual books? Storage: Keep them away from direct sunlight and in a dry environment. Handling: Avoid folding pages, use bookmarks, and handle them with clean hands. Cleaning: Gently dust

- the covers and pages occasionally.
5. Can I borrow books without buying them? Public Libraries: Local libraries offer a wide range of books for borrowing. Book Swaps: Community book exchanges or online platforms where people exchange books.
 6. How can I track my reading progress or manage my book collection? Book Tracking Apps: Goodreads, LibraryThing, and Book Catalogue are popular apps for tracking your reading progress and managing book collections. Spreadsheets: You can create your own spreadsheet to track books read, ratings, and other details.
 7. What are Johnson 70 Hp Manual audiobooks, and where can I find them? Audiobooks: Audio recordings of books, perfect for listening while commuting or multitasking. Platforms: Audible, LibriVox, and Google Play Books offer a wide selection of audiobooks.
 8. How do I support authors or the book industry? Buy Books: Purchase books from authors or independent bookstores. Reviews: Leave reviews on platforms like Goodreads or Amazon. Promotion: Share your favorite books on social media or recommend them to friends.
 9. Are there book clubs or reading communities I can join? Local Clubs: Check for local book clubs in libraries or community centers. Online Communities: Platforms like Goodreads have virtual book clubs and discussion groups.
 10. Can I read Johnson 70 Hp Manual books for free? Public Domain Books: Many classic books are available for free as they're in the public domain. Free E-books: Some websites offer free e-books legally, like Project Gutenberg or Open Library.

Find Johnson 70 Hp Manual :

[mapping gender in ancient religious discourses](#)

[manualidades como hacer llaveros de listones](#)

[manually program samsung fascinate](#)

[marachiara sauce recipe](#)

[manuale navigatore fiat stilo](#)

[marantz st7001 user guide](#)

[manuale tecnico hp 2550](#)

[manuale opel omega](#)

[manualul electricianului finder chorus electric solutii](#)

[marching reference manual](#)

manuel hurricane cooper

~~map of southern colony 5th grade~~

~~many unpleasant returns a rudley mystery~~

~~marantz nr1402 manual~~

march 2physics common paper examplar

Johnson 70 Hp Manual :

never caught the washingtons relentless pursuit of - Apr 29 2023

web feb 7 2017 never caught the washingtons relentless pursuit of their runaway slave ona judge erica armstrong dunbar
simon and schuster feb 7 2017

never caught summary enotes com - Feb 25 2023

web subscribe for 3 a month the washingtons choose additional slaves to bring with them to philadelphia having been
unhappy with the white indentured servants they employed in

never caught the washingtons relentless pursuit of their - Oct 24 2022

web department of history the school of arts and sciences rutgers the state university of new jersey

never caught the washingtons relentless pursuit of their - May 19 2022

web dec 16 2020 simon and schuster 2017 a startling and eye opening look into america s first family never caught the
washingtons relentless pursuit of their runaway

never caught the washingtons relentless pursuit of - Sep 03 2023

web in never caught the washingtons relentless pursuit of their runaway slave erica armstrong dunbar traces the life of slave
ona judge from shortly before her birth to just

never caught the washingtons relentless pursuit of their - Jan 15 2022

never caught kirkus reviews - Mar 17 2022

never caught summary and study guide supersummary - May 31 2023

web oct 23 2018 one of the washington s enslaved emerges from the shadows of her owners and their fame in erica
armstrong dunbar s book never caught the washingtons

never caught the washingtons relentless pursuit of - Jan 27 2023

web never caught the washingtons relentless pursuit of their runaway slave ona judge is a startling and eye opening look into

america s first family never caught is the

never caught study guide literature guide litcharts - Aug 02 2023

web feb 7 2017 never caught the washingtons relentless pursuit of their runaway slave ona judge erica armstrong dunbar simon and schuster feb 7 2017

never caught the washingtons relentless pursuit of their - Apr 17 2022

web we would like to show you a description here but the site won t allow us

never caught the washingtons relentless pursuit of - Nov 24 2022

web erica armstrong dunbar is charles and mary beard professor of history at rutgers university and the author of never caught the washingtons relentless pursuit of their runaway slave ona judge eric foner moderator is dewitt clinton professor emeritus of history at columbia university purchasing tickets

scribd - Nov 12 2021

never caught the washingtons relentless pursuit of their - Mar 29 2023

web jun 13 2022 season 1 episode 40 new york historical society in may of 1796 22 year old ona judge escaped enslavement from the household of the most powerful man in

never caught chapters 4 7 summary analysis supersummary - Sep 22 2022

web bibliographic information when george and martha washington moved from their beloved mount vernon in virginia to philadelphia then the seat of the nation s capital

podcast erica armstrong dunbar never caught the - Dec 14 2021

never caught the washingtons relentless pursuit of their - Dec 26 2022

web mar 6 2020 here is a quick description and cover image of book never caught the washingtons relentless pursuit of their runaway slave ona judge written by erica

never caught the washingtons relentless pursuit of their - Feb 13 2022

never caught the washingtons relentless pursuit of their - Jun 19 2022

web listen to this episode from for the ages a history podcast on spotify in may of 1796 22 year old ona judge escaped enslavement from the household of the most powerful man in the united states george washington soon thereafter she became the subject of an intense manhunt led by washington himself in a discussion that spans her scholarship

never caught wikipedia - Jul 01 2023

web sep 5 2023 never caught the washingtons relentless pursuit of their runaway slave ona judge is a 2017 historical biography written by american author historian

never caught the washingtons relentless pursuit of th - Oct 04 2023

never caught the washingtons relentless pursuit of their runaway slave ona judge is a non fiction book by american historian erica armstrong dunbar published in 2017 the book chronicles the life of ona judge an enslaved woman owned by george and martha washington and her escape from the president s household in philadelphia in 1796

pdf epub never caught the washingtons relentless - Jul 21 2022

web feb 19 2019 never caught the washingtons relentless pursuit of their runaway slave ona judge a startling and eye opening look into america s first family never

never caught erica armstrong dunbar - Aug 22 2022

web feb 7 2017 never caught ona judge the washingtons and the relentless pursuit of their runaway slave by erica armstrong dunbar

diabetes daran denken erkennen beherrschen abebooks - Aug 27 2022

web diabetes daran denken erkennen beherrschen 5 tabellen e rudolf froesch eugen j schoenle unter mitarb von giatgen a spinas begr von hans ulrich frehner bei abebooks de isbn 10 3133319051 isbn 13 9783133319058 hardcover

diabetes daran denken erkennen beherrschen paperback - Jul 26 2022

web diabetes daran denken erkennen beherrschen froesch ernst rudolf schoenle eugen j spinas giatgen a frehner hans ulrich 9783133319065 books amazon ca

h u frehner und e r froesch diabetes daran denken erkennen - Jul 06 2023

web h u frehner und e r froesch diabetes daran denken erkennen beherrschen 4 aufl 257 seiten 8 abb 2 farbtafeln 11 tab georg thieme verlag stuttgart new york 1984

diabetes daran denken erkennen beherrschen 5 tabellen e - Sep 08 2023

web diabetes daran denken erkennen beherrschen 5 tabellen e rudolf froesch eugen j schoenle unter mitarb von giatgen a spinas begr von hans ulrich frehner on amazon com free shipping on qualifying offers diabetes daran denken erkennen beherrschen 5 tabellen e rudolf froesch eugen j schoenle

diabetes daran denken erkennen beherrschen 5 abebooks - Nov 29 2022

web abebooks com diabetes daran denken erkennen beherrschen 5 tabellen e rudolf froesch eugen j schoenle unter mitarb von giatgen a spinas begr von hans ulrich frehner 9783133319058 and a great selection of similar new used and collectible books available now at great prices

9421061 nlm catalog result - Feb 01 2023

web 1 author s froesch e r ernst rudolf 1929 title s diabetes daran denken erkennen beherrschen edition 5 völlig neu bearbeitete aufl e rudolf froesch eugen j schoenle country of publication germany publisher stuttgart new york thieme 1994 description x 181 p ill

8500694 nlm catalog result - Apr 03 2023

web 1 author s frehner hans ulrich title s diabetes daran denken erkennen beherrschen hans ulrich frehner ernst rudolf froesch mit einem beitrage von roland brückner edition 4 neu bearbeitete aufl country of publication germany publisher stuttgart new york thieme 1984 description xiv 257 p 2 p of plates ill

diabetes daran denken erkennen beherrschen softcover - May 04 2023

web abebooks com diabetes daran denken erkennen beherrschen 9783133319065 by froesch ernst rudolf schoenle eugen j spinas giatgen a frehner hans ulrich and a great selection of similar new used and collectible books available now at great prices

diabetes erkennen symptome tests volksversand - Mar 22 2022

web sep 4 2019 typische diabetes symptome im Überblick verstärkter harndrang und nächtliches wasserlassen grund der organismus versucht den übermäßigen zucker im blut über die niere und demzufolge über den urin auszuscheiden starker durst ursache wenn der starke harndrang zu einem wassermangel führt tritt großer durst auf

9783133319058 diabetes daran denken erkennen beherrschen - Jun 05 2023

web diabetes daran denken erkennen beherrschen finden sie alle bücher von froesch ernst r schoenle eugen bei der büchersuchmaschine eurobuch de können sie antiquarische und neubücher vergleichen und sofort zum bestpreis bestellen 9783133319058 ed broschiert pu thieme 5 völlig neu bearbeitete

diabetes gehirn und psyche diabinfo - Apr 22 2022

web der diabetes wird vernachlässigt die stoffwechselkontrolle verschlechtert sich und das risiko für langzeitkomplikationen der erkrankung steigt die gute nachricht es gibt eine reihe erlernbarer methoden und maßnahmen um distress abzubauen ein beispiel ist regelmäßige körperliche aktivität

was macht der diabetes mit dem gedächtnis apotheken - Oct 29 2022

web jul 16 2020 was forschler bisher herausgefunden haben das gehirn vor einer wichtigen prüfung mit traubenzucker zu dopen bei dia betes ist das keine gute idee und auch allen anderen nützt der zuckerschub nicht unbedingt eine studie der berliner charité zeigte ein leicht erhöhter blutzucker kann bei menschen ohne dia betes das gedächtnis

diabetes daran denken erkennen beherrschen open library - Oct 09 2023

web jan 1 1998 diabetes daran denken erkennen beherrschen by ernst rudolf froesch eugen j schoenle giatgen a spinas hans ulrich frehner january 1 1998 thieme stuttgart edition paperback

1 diabetes daran denken erkennen beherrschen zvab - Mar 02 2023

web diabetes daran denken erkennen beherrschen 5 tabellen e rudolf froesch eugen j schoenle unter mitarb von giatgen a spinas begr von hans ulrich frehner beim zvab com isbn 10 3133319051 isbn 13 9783133319058 hardcover

diabetes daran denken erkennen beherrschen - Jun 24 2022

web oct 30 2023 diabetes daran denken erkennen beherrschen omb no 0147635195642 edited by neal aidan die therapie der gegenwart cambridge university press standardwerk für die homöopathische folgeverschreibung welches mittel folgt auf mercurius was antidotiert pulsatilla antworten zu fragen rund um die

diabetes daran denken erkennen zvab - Sep 27 2022

web diabetes daran denken erkennen beherrschen von ernst rudolf froesch und eine große auswahl ähnlicher bücher kunst und sammlerstücke erhältlich auf zvab com

diabetes daran denken erkennen beherrschen zvab - Dec 31 2022

web diabetes daran denken erkennen beherrschen von froesch ernst rudolf schoenle eugen j beim zvab com isbn 10 313331906x isbn 13 9783133319065 thieme georg verlag 1998 softcover

diabetes daran denken erkennen beherrschen amazon de - Aug 07 2023

web diabetes daran denken erkennen beherrschen isbn 9783133319058 kostenloser versand für alle bücher mit versand und verkauf duch amazon

diabetes daran denken erkennen beherrschen lists open - Feb 18 2022

web diabetes daran denken erkennen beherrschen lists this edition is on 0 lists

diabetes daran denken erkennen abebooks - May 24 2022

web diabetes daran denken erkennen behandeln by froesch ernst rudolf and a great selection of related books art and collectibles available now at abebooks com

end of course test geometry mcdougal richard rusczyk - Dec 28 2021

web end of course test geometry mcdougal yeah reviewing a book end of course test geometry mcdougal could ensue your near connections listings this is just one of the solutions for you to be successful

geometry end of course exam mcdougal 2022 yvc moeys gov - Jul 03 2022

web to begin getting this info acquire the geometry end of course exam mcdougal link that we allow here and check out the link you could buy lead geometry end of course exam mcdougal or get it as soon as feasible

geometry end of course exam mcdougal answers copy - Feb 10 2023

web jun 26 2023 download and install the geometry end of course exam mcdougal answers it is unconditionally simple then since currently we extend the member to buy and create bargains to download and install geometry end of course exam

mcdougal answers appropriately simple mcdougal concepts skills geometry mcdougal littell

geometryendofcourseexam mcdougal dev sfcg - Jun 14 2023

web middle school math arkansas prep for end of course exam algebra and geometry integrated math course 2 student edition geometryendofcourseexam mcdougal downloaded from dev sfcg org by guest

geometry end of course assessment weebly - Mar 11 2023

web geometry eoc ma 912 g 1 1 question 3 on a coordinate grid ab has end point b at 24 16 the midpoint of ab is p 4 3 what is the y coordinate of point a item context mathematics draft geometry eoc test item specifications florida department of education 55 geometry eoc ma 912 g 1 3 question 4 in the figure below ab is

geometry end of course exam mcdougal thebookee net - Jul 15 2023

web geometry end of course exam mcdougal list of ebooks and manuels about geometry end of course exam mcdougal

geometry end of course exam mcdougal answers pdf - Apr 12 2023

web mar 15 2023 geometry 2003 resources in spanish to accompany mcdougal littell geometry integrated math course 1 student edition carter 12 2012 03 01 includes print student edition the school world 1908 the gardeners chronicle and agricultural gazette 1860 geometry holt mcdougal 2004 the theorems and principles of basic

end of course test wikipedia - Jan 29 2022

web the end of course test eoct eoc or eoc test is an academic assessment conducted in many states by the state board of education and island of bermuda georgia for example tests from the ninth to twelfth grades and north carolina tests for any of the four core class subjects math science social studies and english

geometry end of course exam mcdougal copy old vulkk - May 13 2023

web geometry end of course exam mcdougal downloaded from old vulkk com by guest andrew cook endof course exam geometry eoc part 1 florida end of course exam practice test geometry final exam review geometry eoc practice test part 2 florida end of course exam geometry final exam review study guide

geometry end of course exam mcdougal prospectus camre ac - Nov 07 2022

web geometry end of course exam mcdougal looking for geometry end of course exam mcdougal pdf download do you really need this book of read and download geometry end of course exam mcdougal answers

holt mcdougal geometry end of course test copy - Dec 08 2022

web nov 17 2022 mcdougal geometry end of course test but stop in the works in harmful downloads rather than enjoying a fine ebook subsequently a cup of coffee in the afternoon otherwise they juggled gone some harmful virus inside their computer holt mcdougal geometry end of course

end of course test geometry mcdougal pdf download only - Aug 04 2022

web end of course test geometry mcdougal pdf pages 2 17 end of course test geometry mcdougal pdf upload herison c robertson 2 17 downloaded from bukuclone ortax org on september 4 2023 by herison c robertson from survivors this report documents the residential school system which forced children into institutions

end of course test holt mcdougal geometry 2022 25years - Mar 31 2022

web jan 24 2023 course test holt mcdougal geometry and numerous books collections from fictions to scientific research in any way in the middle of them is this end of course test holt mcdougal geometry that can be your partner

mc dougal littell high school math arkansas preparation for the end - Feb 27 2022

web mc dougal littell high school math arkansas preparation for the end of course exam geometry m c d o u g a l l i t t e l state province and national reporting maid in seattle 403873 295357

end of course geometry preview end of course geometry - Oct 06 2022

web preview end of course geometry pdf geometry 5 directions read each question carefully and choose the best answer then mark the space on your answer document for the answer you have chosen

geometry end of course exam mcdougal answers copy - Sep 05 2022

web jul 3 2023 geometry end of course exam mcdougal answers 1 3 downloaded from uniport edu ng on july 3 2023 by guest geometry end of course exam mcdougal answers this is likewise one of the factors by obtaining the soft documents of this geometry end of course exam mcdougal answers by online

uludag edu tr - May 01 2022

web fren deneyi sorulari 1 aşığıda bulunan 50km h ve 100km h lik hızlarla yapılan deneylerin grafiklerini araç ağırlığı yol durumu

geometry end of course exam mcdougal answers 2022 - Jan 09 2023

web geometry end of course exam mcdougal answers 1 geometry end of course exam mcdougal answers end of course eoc assessments endof course exam geometry end of course flashcards quizlet geometry end of course exam end of course exams geometry examred com geometry ohio department of education

geometry end of course exam mcdougal answers - Jun 02 2022

web a geometry end of course exam mcdougal tourps de june 12th 2018 read and download geometry end of course exam mcdougal free ebooks in pdf format 1 hour geometry review guide for the end of course sat act and asset tests geometry end of course test answers holt

end of course test wordpress com - Aug 16 2023

web 240 holt mcdougal geometry end of course test 23 the figure represents a rectangular gate with diagonal braces to the nearest tenth what is the width qt of the gate f 15 21 h a 3 9 ft c 7 0 ft b 4 9 ft d c 7 6 ft refer to the figure for exercises 24

and 25 f 15 ft h 24 kim is making a kite with a wooden