

# Internal Assembly Locations

Figure 1-6 Internal Assembly Locations (1 of 2)

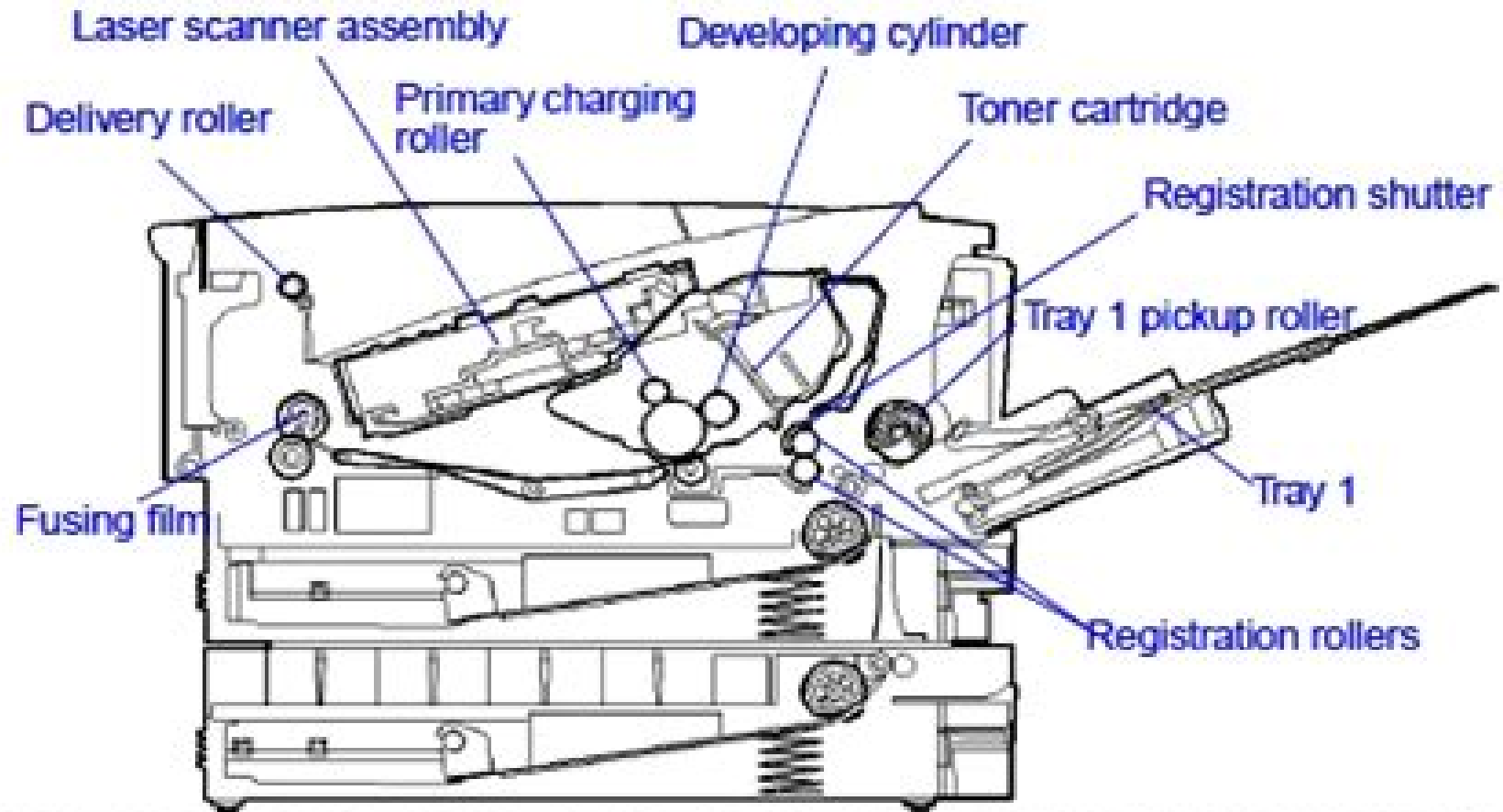

Preview: HP LaserJet 2100 service manual

[Download Now!](#)

# Hp Laserjet 2100 Printer Repair Manual

**RD Boyd**



## **Hp Laserjet 2100 Printer Repair Manual:**

## Unveiling the Magic of Words: A Overview of "**Hp Laserjet 2100 Printer Repair Manual**"

In a world defined by information and interconnectivity, the enchanting power of words has acquired unparalleled significance. Their capability to kindle emotions, provoke contemplation, and ignite transformative change is actually awe-inspiring. Enter the realm of "**Hp Laserjet 2100 Printer Repair Manual**," a mesmerizing literary masterpiece penned by way of a distinguished author, guiding readers on a profound journey to unravel the secrets and potential hidden within every word. In this critique, we shall delve to the book is central themes, examine its distinctive writing style, and assess its profound effect on the souls of its readers.

<https://staging.conocer.cide.edu/files/browse/Documents/Konica%20Minolta%20C350%20Guide.pdf>

### **Table of Contents Hp Laserjet 2100 Printer Repair Manual**

1. Understanding the eBook Hp Laserjet 2100 Printer Repair Manual
  - The Rise of Digital Reading Hp Laserjet 2100 Printer Repair Manual
  - Advantages of eBooks Over Traditional Books
2. Identifying Hp Laserjet 2100 Printer Repair Manual
  - Exploring Different Genres
  - Considering Fiction vs. Non-Fiction
  - Determining Your Reading Goals
3. Choosing the Right eBook Platform
  - Popular eBook Platforms
  - Features to Look for in an Hp Laserjet 2100 Printer Repair Manual
  - User-Friendly Interface
4. Exploring eBook Recommendations from Hp Laserjet 2100 Printer Repair Manual
  - Personalized Recommendations
  - Hp Laserjet 2100 Printer Repair Manual User Reviews and Ratings
  - Hp Laserjet 2100 Printer Repair Manual and Bestseller Lists

5. Accessing Hp Laserjet 2100 Printer Repair Manual Free and Paid eBooks
  - Hp Laserjet 2100 Printer Repair Manual Public Domain eBooks
  - Hp Laserjet 2100 Printer Repair Manual eBook Subscription Services
  - Hp Laserjet 2100 Printer Repair Manual Budget-Friendly Options
6. Navigating Hp Laserjet 2100 Printer Repair Manual eBook Formats
  - ePub, PDF, MOBI, and More
  - Hp Laserjet 2100 Printer Repair Manual Compatibility with Devices
  - Hp Laserjet 2100 Printer Repair Manual Enhanced eBook Features
7. Enhancing Your Reading Experience
  - Adjustable Fonts and Text Sizes of Hp Laserjet 2100 Printer Repair Manual
  - Highlighting and Note-Taking Hp Laserjet 2100 Printer Repair Manual
  - Interactive Elements Hp Laserjet 2100 Printer Repair Manual
8. Staying Engaged with Hp Laserjet 2100 Printer Repair Manual
  - Joining Online Reading Communities
  - Participating in Virtual Book Clubs
  - Following Authors and Publishers Hp Laserjet 2100 Printer Repair Manual
9. Balancing eBooks and Physical Books Hp Laserjet 2100 Printer Repair Manual
  - Benefits of a Digital Library
  - Creating a Diverse Reading Collection Hp Laserjet 2100 Printer Repair Manual
10. Overcoming Reading Challenges
  - Dealing with Digital Eye Strain
  - Minimizing Distractions
  - Managing Screen Time
11. Cultivating a Reading Routine Hp Laserjet 2100 Printer Repair Manual
  - Setting Reading Goals Hp Laserjet 2100 Printer Repair Manual
  - Carving Out Dedicated Reading Time
12. Sourcing Reliable Information of Hp Laserjet 2100 Printer Repair Manual
  - Fact-Checking eBook Content of Hp Laserjet 2100 Printer Repair Manual
  - Distinguishing Credible Sources
13. Promoting Lifelong Learning

- Utilizing eBooks for Skill Development
  - Exploring Educational eBooks
14. Embracing eBook Trends
- Integration of Multimedia Elements
  - Interactive and Gamified eBooks

### **Hp Laserjet 2100 Printer Repair Manual Introduction**

Free PDF Books and Manuals for Download: Unlocking Knowledge at Your Fingertips In today's fast-paced digital age, obtaining valuable knowledge has become easier than ever. Thanks to the internet, a vast array of books and manuals are now available for free download in PDF format. Whether you are a student, professional, or simply an avid reader, this treasure trove of downloadable resources offers a wealth of information, conveniently accessible anytime, anywhere. The advent of online libraries and platforms dedicated to sharing knowledge has revolutionized the way we consume information. No longer confined to physical libraries or bookstores, readers can now access an extensive collection of digital books and manuals with just a few clicks. These resources, available in PDF, Microsoft Word, and PowerPoint formats, cater to a wide range of interests, including literature, technology, science, history, and much more. One notable platform where you can explore and download free Hp Laserjet 2100 Printer Repair Manual PDF books and manuals is the internet's largest free library. Hosted online, this catalog compiles a vast assortment of documents, making it a veritable goldmine of knowledge. With its easy-to-use website interface and customizable PDF generator, this platform offers a user-friendly experience, allowing individuals to effortlessly navigate and access the information they seek. The availability of free PDF books and manuals on this platform demonstrates its commitment to democratizing education and empowering individuals with the tools needed to succeed in their chosen fields. It allows anyone, regardless of their background or financial limitations, to expand their horizons and gain insights from experts in various disciplines. One of the most significant advantages of downloading PDF books and manuals lies in their portability. Unlike physical copies, digital books can be stored and carried on a single device, such as a tablet or smartphone, saving valuable space and weight. This convenience makes it possible for readers to have their entire library at their fingertips, whether they are commuting, traveling, or simply enjoying a lazy afternoon at home. Additionally, digital files are easily searchable, enabling readers to locate specific information within seconds. With a few keystrokes, users can search for keywords, topics, or phrases, making research and finding relevant information a breeze. This efficiency saves time and effort, streamlining the learning process and allowing individuals to focus on extracting the information they need. Furthermore, the availability of free PDF books and manuals fosters a culture of continuous learning. By removing financial barriers, more people can access educational resources and pursue lifelong

learning, contributing to personal growth and professional development. This democratization of knowledge promotes intellectual curiosity and empowers individuals to become lifelong learners, promoting progress and innovation in various fields. It is worth noting that while accessing free Hp Laserjet 2100 Printer Repair Manual PDF books and manuals is convenient and cost-effective, it is vital to respect copyright laws and intellectual property rights. Platforms offering free downloads often operate within legal boundaries, ensuring that the materials they provide are either in the public domain or authorized for distribution. By adhering to copyright laws, users can enjoy the benefits of free access to knowledge while supporting the authors and publishers who make these resources available. In conclusion, the availability of Hp Laserjet 2100 Printer Repair Manual free PDF books and manuals for download has revolutionized the way we access and consume knowledge. With just a few clicks, individuals can explore a vast collection of resources across different disciplines, all free of charge. This accessibility empowers individuals to become lifelong learners, contributing to personal growth, professional development, and the advancement of society as a whole. So why not unlock a world of knowledge today? Start exploring the vast sea of free PDF books and manuals waiting to be discovered right at your fingertips.

### **FAQs About Hp Laserjet 2100 Printer Repair Manual Books**

How do I know which eBook platform is the best for me? Finding the best eBook platform depends on your reading preferences and device compatibility. Research different platforms, read user reviews, and explore their features before making a choice. Are free eBooks of good quality? Yes, many reputable platforms offer high-quality free eBooks, including classics and public domain works. However, make sure to verify the source to ensure the eBook credibility. Can I read eBooks without an eReader? Absolutely! Most eBook platforms offer web-based readers or mobile apps that allow you to read eBooks on your computer, tablet, or smartphone. How do I avoid digital eye strain while reading eBooks? To prevent digital eye strain, take regular breaks, adjust the font size and background color, and ensure proper lighting while reading eBooks. What the advantage of interactive eBooks? Interactive eBooks incorporate multimedia elements, quizzes, and activities, enhancing the reader engagement and providing a more immersive learning experience. Hp Laserjet 2100 Printer Repair Manual is one of the best book in our library for free trial. We provide copy of Hp Laserjet 2100 Printer Repair Manual in digital format, so the resources that you find are reliable. There are also many Ebooks of related with Hp Laserjet 2100 Printer Repair Manual. Where to download Hp Laserjet 2100 Printer Repair Manual online for free? Are you looking for Hp Laserjet 2100 Printer Repair Manual PDF? This is definitely going to save you time and cash in something you should think about.

**Find Hp Laserjet 2100 Printer Repair Manual :**

**konica minolta c350 guide**

[kogan led tv user manual](#)

[konica minolta 7450 technical manual](#)

**komatsu 240 manual operador gratuito**

[kodiak 350 manual](#)

[komatsu pc 400 manual](#)

[komatsu pc130-7 operation manual](#)

**komatsu d155ax 3 manual**

[komatsu pc40 7 operation and maintenance manual](#)

[konica minolta bizhub c280 service manual](#)

[kohler magnum model m12 12hp engine full service repair manual](#)

**konica c450 user manual**

**komatsu wa40 1 wheel loader service repair manual 1001 and up**

[komatsu pc400lc 6 pc400hd 6 hydraulic excavator operation maintenance manual](#)

**kodak zi8 manual user guide**

**Hp Laserjet 2100 Printer Repair Manual :**

[pagliaros comprehensive guide to drugs and substances of](#) - Feb 28 2023

web pagliaro pharmacopsychology university of alberta canada analyzes trends in the abuse of both prescribed medications and illicit substances not covered in standard

**pagliaros comprehensive guide to drugs and substances of abuse** - Jan 30 2023

web 1 0 restricted access book review first published november december 2004 pagliaros comprehensive guide to drugs and substances of abuse michelle gravlin twitty

**drugs of abuse a dea resource guide 2020 edition dea gov** - Aug 05 2023

web this comprehensive guide provides important information about the harms and consequences of drug use by describing a drug s effects on the body and mind

**karch s drug abuse handbook 3rd edition routledge** - Sep 25 2022

web nov 23 2011 this handbook provides a comprehensive up to date overview of the nature and extent of substance use by



children and adolescents the authors examine

*substance use disorders psychiatry* - Jul 24 2022

web pagliaros comprehensive guide to drugs and substances of abuse article zed2005pagliaroscg title pagliaros

comprehensive guide to drugs and

drugs of abuse a reference guide to their history and use - Mar 20 2022

web feb 1 2004 comprehensive guide to drugs and substances of abuse by louis a pagliaro ann marie pagliaro louis pagliaro

apha publications hardcover english

**pagliaro s comprehensive guide to drugs and substances of** - Dec 17 2021

web nov 24 2020 drug misuse is considered to be the misuse of medicine and incorrect use of drugs or medicines with the intention of causing body changes it can also be said to be

**pagliaros comprehensive guide to drugs and substances of abuse** - May 22 2022

web summary this comprehensive reference guide describes more than 130 alphabetically arranged drugs of abuse including both pharmaceutical and natural products the book

pagliaros comprehensive guide to drugs and substances of abuse - Jun 22 2022

web request pdf on feb 15 2005 peter j zed published pagliaros comprehensive guide to drugs and substances of abuse find read and cite all the research you need on

**pagliaros comprehensive guide to drugs and substances of abuse** - Nov 27 2022

web drugs and substances of abuse are used both medically and personally for their specific actions on the central nervous system by children adolescents and adults across north

pagliaros comprehensive guide to drugs and substances of - Sep 06 2023

web pagliaros comprehensive guide to drugs and substances of abuse pagliaro louis a pagliaro ann m free download borrow and streaming internet archive by

*u s and israeli officials claim hamas was high during oct 7* - Jul 12 2021

pagliaros comprehensive guide to drugs and - Apr 20 2022

web substance abuse wikipedia from wikipedia the free encyclopedia also known as is the use of a drug in amounts or by methods that are harmful to the individual or others it

substance abuse wikipedia - Feb 16 2022

web jan 1 2009 read reviews from the world s largest community for readers pagliaros comprehensive guide to drugs and substances of abuse 2nd edition has been

*comprehensive guide to drugs and substances of abuse* - Jan 18 2022

web dec 21 2006 alcohol and drug abuse handbook april 1989 american journal of occupational therapy virginia c stoffel  
request pdf on dec 21 2006 steven b

**drugs of abuse a dea resource guide 2022 edition** - Jun 03 2023

web learn about the most commonly used and misused drugs in the us with the 2022 drugs of abuse resource guide a  
comprehensive and updated pdf from the dea

drug abuse handbook request pdf researchgate - Nov 15 2021

web oct 31 2023 start preamble agency substance abuse and mental health services administration hhs action notice  
summary the department of health and

**pagliaros comprehensive guide to drugs and substances of abuse** - Oct 07 2023

web feb 15 2005 pagliaros comprehensive guide to drugs and substances of abuse was written to provide general health  
care professionals with a timely authoritative scholarly

**comprehensive guide to drugs and substances of** - Jul 04 2023

web this comprehensive guide provides important information about the harms and consequences of drug use by describing a  
drug s effects on the body and mind

home dea gov - May 02 2023

web pagliaros comprehensive guide to drugs and substances of abuse published by the american pharmacists association the  
text is a great reference book for practicing

**handbook of child and adolescent drug and substance abuse** - Aug 25 2022

web this pdf document provides a concise and evidence based overview of the diagnosis and treatment of substance use  
disorders based on the apa s practice guideline it covers

**federal register current list of hhs certified laboratories and** - Sep 13 2021

web nov 3 2023 drug use by soldiers especially the use of stimulants is common throughout the 1950s and 1960s the  
pentagon kept nuclear equipped b 52 bombers in

**pagliaros comprehensive guide to drugs and substances of abuse** - Oct 27 2022

web karch s drug abuse handbook third edition remains the quintessential compendium addressing the pharmacological  
medical and legal aspects of drugs and informing the

**pagliaros comprehensive guide to drugs and substances of abuse** - Apr 01 2023

web pagliaros comprehensive guide to drugs and substances of abuse michelle gravlin twitty pharmd bcpp journal of  
pharmacy technology 2004 20 6 359 360 share

**us daylight saving time when do clocks change and why was it** - Aug 13 2021

pagliaros comprehensive guide to drugs and substances of abuse - Dec 29 2022

web pagliaros comprehensive guide to drugs and substances of abuse offers a timely authoritative referenced analysis of trends in abuse of both prescribed medications and

**drugs and substance abuse knec notes and revision materials** - Oct 15 2021

web oct 31 2023 when does daylight saving time end in 2023 daylight saving time in the u s and some neighbouring countries will end on nov 5 at 2 a m local time

orange tome 3 03 pdf free devy ortax - Nov 05 2022

web orange tome 3 03 pdf introduction orange tome 3 03 pdf free title orange tome 3 03 pdf free devy ortax org created date 9 4 2023 4 53 51 am

**orange cilt 3 içigo takano fiyat satın al d r** - Oct 04 2022

web İki gücünü birleştirerek mektupta yazılanları gerçekleştirmeye çalışırlar ancak gelecek farklılaşmaya başlayınca mektup ile gerçekte yaşananlar orantısız olmaya başlar

amazon com orange vol 3 ebook takano ichigo takano - Jan 27 2022

web nov 9 2016 learn more paperback 16 13 3 used from 10 04 10 new from 8 00 on the day that naho begins 11th grade she receives a letter from herself ten years in the

orange tome 3 03 amazon com tr kitap - Aug 14 2023

web arama yapmak istediğiniz kategoriye seçin

**9782369740537 orange tome 3 vf 03 abebooks** - Jan 07 2023

web orange tome 3 vf 03 by takano ichigo at abebooks co uk isbn 10 2369740531 isbn 13 9782369740537 akata 2015 softcover

**amazon in customer reviews orange tome 3 vol03** - Dec 26 2021

web find helpful customer reviews and review ratings for orange tome 3 vol03 at amazon com read honest and unbiased product reviews from our users

orange tome 3 03 takano ichigo amazon com au books - Feb 08 2023

web select the department you want to search in

**orange tome 3 03 french edition amazon com au** - Apr 29 2022

web orange tome 3 03 french edition tokiumi yui takano ichigo amazon com au books

**tome 3 vf 03 takano ichigo 9782369740537 abebooks** - Mar 09 2023

web synopsis about this edition suite à l'incroyable révélation que suwa lui a faite naho est troublée car si elle a conscience qu'elle ne peut répondre aux sentiments de son ami

[orange tome 3 by ichigo takano 2015 biblio](#) - Nov 24 2021

web find orange tome 3 by ichigo takano 2015 seven seas entertainment llc 2017 paperback acceptable disclaimer a readable copy

[orange tome 3 03](#) - Dec 06 2022

web lire écrire créer lire écrire créer

**orange tome 3 by ichigo takano the storygraph** - Mar 29 2022

web orange tome 3 orange 3 ichigo takano with chiharu chujo translator fiction

[orange tome 3 03 takano ichigo amazon com tr kitap](#) - Jul 13 2023

web orange tome 3 03 takano ichigo amazon com tr kitap ana içeriğe atla com tr merhaba teslimat adresini seçin kitaplar merhaba giriş yapın hesap ve listeler değil

[9782369742708 orange tome 3 03 abebooks](#) - Apr 10 2023

web abebooks com orange tome 3 03 9782369742708 by tokiumi yui takano ichigo and a great selection of similar new used and collectible books available now at great

**orange tome 3 vol03 paperback 12 february 2015 amazon in** - Jul 01 2022

web amazon in buy orange tome 3 vol03 book online at best prices in india on amazon in read orange tome 3 vol03 book reviews author details and more at amazon in

[orange 3 03 3 by ichigo takano goodreads](#) - Aug 02 2022

web aug 22 2014 [orange 3 03 3 by ichigo takano goodreads](#) orange 9 12 orange 1 2

**orange tome 3 by ichigo takano the storygraph** - Feb 25 2022

web orange tome 3 orange 3 ichigo takano with chiharu chujo translator 191 pages first pub 2014 isbn uid 9782369740537 format paperback language french

**orange tome 3 03 paperback illustrated 11 jan 2018** - Oct 24 2021

web buy orange tome 3 03 by tokiumi yui takano ichigo okada sayaka debienne manon isbn 9782369742708 from amazon s book store everyday low prices and

[orange tome 3 vf 03 amazon co uk](#) - Jun 12 2023

web buy orange tome 3 vf 03 by takano ichigo isbn 9782369740537 from amazon s book store everyday low prices and free delivery on eligible orders

**orange tome 3 03 tokiumi yui takano ichigo abebooks** - May 11 2023

web orange tome 3 03 by tokiumi yui takano ichigo at abebooks co uk isbn 10 2369742704 isbn 13 9782369742708 akata 2018 softcover

[browse editions for orange tome 3 the storygraph](#) - Sep 03 2022

web open main menu home reading challenges community giveaways sign in contact us

[orange tome 3 03 help environment harvard edu](#) - May 31 2022

web this is likewise one of the factors by obtaining the soft documents of this orange tome 3 03 by online you might not require more get older to spend to go to the book creation as

*das glück hat vier farben bücher de* - Apr 30 2023

web eigentlich könnte man denken dass das glück hat vier farben ein einfacher jugendroman über das leben ist doch schon nach wenigen seiten ist klar wie viel

*das gluck hat vier farben helpdesk bricksave com* - Feb 14 2022

web das gluck hat vier farben 1 das gluck hat vier farben polytechnisches centralblatt diskrete mathematik für einsteiger constitutionelles blatt aus böhmen mu der

**dog das glück hat vier pfofen apple tv at** - Dec 15 2021

web dog das glück hat vier pfofen erhältlich bei itunes der ehemalige army ranger jackson briggs channing tatum ist auf der suche nach einem neuanfang als er auf

**lisa moore das glück hat vier farben kasimira** - Jun 01 2023

web 22 mai 2017 die kana di sche preis ge krön te autorin lisa moore hat mit das glück hat vier farben einen ers ten jugend roman geschrie ben der zugleich das por trät einer

[welche farbe hat das glück bilderbuchlesung hörbuch für kinder](#) - Mar 18 2022

web in diesem video lese ich euch das bilderbuch welche farbe hat das glück von elfriede wimmer und petra probst vor beim spielen und singen vergisst die wut

**das gluck hat vier farben assets ceu social** - Dec 27 2022

web enter the realm of das gluck hat vier farben a mesmerizing literary masterpiece penned by way of a distinguished author guiding readers on a profound journey to

[das glück hat vier farben hardcover 27 april 2017 amazon de](#) - Mar 30 2023

web apr 7 2017 select the department you want to search in

*das gluck hat vier farben pqr uiaf gov co* - Nov 13 2021

web das gluck hat vier farben is comprehensible in our digital library an online right of entry to it is set as public thus you can download it instantly our digital library saves in multiple

das gluck hat vier farben copy videos bookbrush - Apr 18 2022

web 2 das gluck hat vier farben 2023 07 08 die ich zum einfachen verständnis graphisch überarbeitet habe sie zeigen auf wie die ragdoll aussehen sollte oder eben nicht zu

**das glück hat vier farben lovelybooks** - Aug 03 2023

web apr 27 2017 das glück hat vier farben von lisa moore 3 5 sterne bei 35 bewertungen bestellen bei amazon neue kurzmeinungen positiv 19 fina vor 3 jahren ein sehr

**dasgluckhatvierfarben** - Nov 25 2022

web universally compatible das gluck hat vier farben pdf aug 23 2023 das gluck hat vier farben comptes rendus jan 07 2022 the new and complete dictionary of the german and

das glück ist dunkel album by veronika faber spotify - Jan 16 2022

web listen to das glück ist dunkel on spotify veronika faber album 2005 14 songs veronika faber album 2005 14 songs sign up log in home search your library

*das gluck hat vier farben wladislaw jachtchenko* - Jul 22 2022

web das gluck hat vier farben when somebody should go to the ebook stores search instigation by shop shelf by shelf it is in point of fact problematic this is why we present

*welche farbe hat das glück das bilderbuch über gefühle* - May 20 2022

web welche farbe hat das glück ein bilderbuch über gefühle was sind gefühle gefühle kann man spüren erleben aber selbst nicht sehen sehen kann man nur den

**das glück hat vier farben gebundene ausgabe 27 april 2017** - Oct 05 2023

web das glück hat vier farben moore lisa illinger maren isbn 9783737354806 kostenloser versand für alle bücher mit versand und verkauf duch amazon

das glück hat vier farben by lisa moore goodreads - Sep 04 2023

web may 10 2016 read 116 reviews from the world s largest community for readers seit sie denken kann ist die sechzehnjährige flannery in tyrone verliebt aber wann genau

*das gluck hat vier farben pdf* - Jul 02 2023

web vier farben der magie oct 16 2022 vier farben der magie ist der erste band von v e schwabs groer fantasy trilogie um den magier und weltenwanderer kell und um

*griinsekatzes review of das glück hat vier farben goodreads* - Feb 26 2023

web das glück hat vier farben von lisa moore ist ein buch dass zu viele geschichten zeitgleich erzählt und somit den roten faden verliert der klappentext verspricht einen

[lisa moore das glück hat vier farben bayern](#) - Jan 28 2023

web mit tyron wird es trotzdem nichts aber für flannery wie auch für ihre mutter zeichnet sich am ende privates glück ab moore eine autorin die schon für den bookerprize

**das glück hat vier farben copy cyberlab sutd edu sg** - Aug 23 2022

web vier farben der magie dec 17 2022 vier farben der magie ist der erste band von v e schwabs großer fantasy trilogie um den magier und weltenwanderer kell und um

[das glück hat vier farben pdf uniport edu](#) - Oct 25 2022

web das glück hat vier farben 1 7 downloaded from uniport edu ng on march 31 2023 by guest das glück hat vier farben as recognized adventure as without difficulty as experience

*das glück hat vier farben pqr uiaf gov co* - Sep 23 2022

web das glück hat vier farben as recognized adventure as well as experience just about lesson amusement as skillfully as concord can be gotten by just checking out a books

*das glück hat vier farben pdf cyberlab sutd edu sg* - Jun 20 2022

web vier farben satz jul 04 2022 in diesem buch zeigt michael thiel warum sich mit logischen instrumentarien das vier farben theorem bestätigt in seinem ansatz zeigt